

NEW ZEALAND ASBESTOS CEMENT WATERMAIN MANUAL



August 2001

PREPARED FOR

NEW ZEALAND WATER AND WASTES ASSOCIATION
WATER SUPPLY MANAGERS GROUP

BY

OPUS INTERNATIONAL CONSULTANTS
CHRISTCHURCH, NEW ZEALAND



New Zealand Asbestos Cement Watermain Manual

TABLE OF CONTENTS

ACKNOWLEDGEMENTS
INTRODUCTION

SECTION 1

NATIONAL SPECIFICATION FOR SAMPLING AND TESTING OF ASBESTOS
CEMENT WATERMAINS

SECTION 2

NATIONAL AC WATERMAIN DATABASE AND LIFETIME PREDICTION MODEL
DEVELOPMENT AND APPLICATION

SECTION 3

MASTER DATABASE AND MODEL

SECTION 4

WORKING DATABASE AND MODEL

SECTION 5

CONDITION RATING OF ASBESTOS CEMENT WATERMAIN (FUTURE)

NOTE: ALL DOCUMENTATION IS INCLUDED ON THE CD-ROM PROVIDED WITH THIS MANUAL.

ACKNOWLEDGEMENTS

THANKS TO JOHN BLACK AND TEAM AT OPUS INTERNATIONAL CONSULTANTS OFFICE IN CHRISTCHURCH FOR THEIR INTEREST AND DEDICATION TO THE TASK. THANKS ALSO TO THE PROJECT SUBCOMMITTEE COMPRISING JOHN OLDFIELD (PORIRUA CITY COUNCIL) AND ANDREW DIXON (EX NORTH SHORE CITY COUNCIL), AND THE STAFF AT NZWWA FOR COLLATING THIS MANUAL.

Richard Taylor, Project Subcommittee Leader
EcoWater Solutions, Waitakere City Council
August 2001

ISBN 1-877134-32-5

New Zealand Asbestos Cement Watermain Manual was published by New Zealand Water and Wastes Association Inc., Water Supply Managers Group, August 2001.

P O Box 13 880, Onehunga, Auckland 1006.
Telephone: +64 9 636 3636
Facsimile: +64 9 636 1234
Email: water@nzwwa.org.nz
Website: <http://www.nzwwa.org.nz>

© COPYRIGHT – INTELLECTUAL PROPERTY RIGHTS – NOTICE OF INFORMATION

The information contained within this document is COPYRIGHTED to New Zealand Water and Wastes Association, who shall retain copyright and all intellectual property rights to any and all work prepared under this contract by the consultant or contractor. This information may be LEGALLY PRIVILEGED, intended only for the individual(s) it is intended for. If you are the intended recipient, any portion of this document must not be used without written permission from New Zealand Water and Wastes Association. If you are not the intended recipient, you are hereby notified that any use, review, dissemination, distribution or copying of this document is strictly prohibited.

The NZWWA manuals are published on the understanding that: The NZWWA and individual contributors are not responsible for the results of any actions taken on the basis of information in this manual. The NZWWA make no representation or warranty of any kind, whether expressed or implied, concerning the product, accuracy, or process discussed in this publication and assumes no liability. Anyone using this information assumes all liability arising from such use, including but not limited to infringement of any patent or patents.

INTRODUCTION

In 1997 a nationwide survey on asbestos cement pipes in water supply and drainage systems was carried out. The responses received represented a population of 2 million. The results indicated that 97% of respondents had asbestos cement pipe in service for water supply purposes and that asbestos cement pipes comprise approximately 36% of piping in public water supply systems. More importantly the 1997 survey showed that most problems experienced with asbestos cement water pipe occur after 30 years and 50% of all asbestos cement pipes were older than 25 years.

Unlike most other pipe materials, softening of the pipe walls is known to be occurring in asbestos cement watermains and hence structural failure of these pipes is inevitable. Thus the issue of life expectancy of asbestos cement watermains is a very important one for water supply authorities in terms of renewal planning, funding/depreciation issues and maintaining acceptable levels of service.

In 1998 an Asbestos Cement Watermain Condition Rating Project was set up under the Water Supply Managers Group and the first task was the development of a national specification for the sampling and testing of asbestos cement watermains. This document was completed by Opus International Consultants Limited late in 1998 and has since been subject to minor amendments.

At the time of writing, 20 water suppliers have had 269 pipe samples extracted and tested, and this test data forms the basis of the lifetime prediction analysis and curves developed by Opus International Consultants. Opus have also been engaged by the NZWWA to hold and maintain a national database of asbestos cement water main test results.

The results of the analysis confirm that the deterioration of asbestos cement pipe is not an exact science, and there are significant variances across samples. The document in the manual entitled *National AC Water Main Database and Lifetime Prediction Model, Development and Application* provides the background to the development of the lifetime prediction curves. These curves are based on national average pipe deterioration rates and will be improved over time as further work is carried out on the deterioration of asbestos cement pipes. Charts have also been prepared showing the *range* of predicted years to failure to give the reader some idea of the variation between samples.

It is proposed that a final section covering a 1 to 5 condition rating for in-service asbestos cement water mains be developed in 2002.

Richard Taylor

Project Subcommittee Leader

PREFACE

There is a growing concern in New Zealand regarding the state of the asbestos cement water mains that form a very significant part of the water supply infrastructure.

In many parts of the country, total deterioration of AC water pipes of 50-mm diameter has occurred and pipes have already been replaced. In some areas, pipes of 100-mm diameter are nearing the end of their useful lifetime, with some having been replaced already. Pipes of 150 mm diameter and larger have generally survived without many unexpected failures, however, some of these pipes can be expected to begin failing in the near future. Pipes of larger sizes still have significant remaining lifetimes, but again, their lifetimes are limited and planning for their renewal over the next 10 - 50 years is a major asset management concern. This issue 3 document has been updated from the previous issue 2 dated 10 Feb 1999. The modifications are of a fairly minor nature. Phenolphthalein indicator has been introduced in the assessment of the depth of deterioration, the radiography test has been deleted and the number of core tests reduced, with the water absorption, pipe density and bench burst test becoming optional.

The primary goal of the testing and evaluation procedures described in this specification is to provide standardised, straightforward and cost-effective methods and procedures for sampling and testing of asbestos cement pressure pipes. The results of testing carried out around the country have provided consistent data that has been used to produce a first generation remaining lifetime prediction model that can be used in planning and optimising the time for water main rehabilitation or renewal works.

The results of AC pipe condition evaluations made using this specification methodology programmes should be submitted to Opus International Consultants so that they can be added to the database and improve the understanding of AC pipe deterioration. The database currently contains the results of testing carried out on more than 250 samples of pipe of various diameters from 50mm to 300mm diameter.

Predictions of the remaining lifetime to the first deterioration failure for any AC pipes can be made using the Lifetime prediction model that has been developed. This model uses the average deterioration rate from the database and requires input of pipe dimensions (wall thickness, outside diameter and observed depth of deterioration), operating pressure and installation date to estimate the remaining lifetime to the first deterioration failure.

CONTENTS

	PAGE
PREFACE	
SECTION 1 SCOPE AND GENERAL	1-1
1.1 SCOPE.....	1-1
1.2 REFERENCED DOCUMENTS	1-1
1.3 DEFINITIONS.....	1-1
SECTION 2 BACKGROUND INFORMATION	1-4
2.1 PIPE SAMPLING.....	1-4
2.2 PIPE SAMPLE SIZE.....	1-4
2.3 BURST FAILURES - PRESSURE RECORD	1-4
2.4 FIELD INSPECTION REPORT	1-5
2.5 FIELD BURSTING PRESSURE.....	1-5
2.6 SOIL SAMPLING.....	1-6
2.7 HEALTH AND SAFETY CONSIDERATIONS.....	1-7
SECTION 3 FIELD INVESTIGATIONS	1-8
3.1 SITE REPORT FORM.....	1-8
3.2 SAMPLE COLLECTION.....	1-8
3.3 EXCAVATION	1-8
3.4 HANDLING AND STORAGE.....	1-8
3.5 BURST FAILURE – PRESSURE RECORD	1-9
3.6 SOIL SAMPLING.....	1-9
3.7 FIELD BURST PRESSURE TESTING	1-9
SECTION 4 IN-SITU PIPE EVALUATION	1-10
4.1 EXTERIOR DETERIORATION ASSESSMENT.....	1-10
4.2 RADIOGRAPHIC EXAMINATION.....	1-10
4.3 LARGE DIAMETER PIPES.....	1-11
SECTION 5 PIPE SAMPLE EVALUATION	1-12
5.1 DETAILS TO BE RECORDED.....	1-12
5.2 PIPE CONDITION OBSERVATIONS	1-12
5.3 SUMMARY OF CORE AND OPTIONAL TESTS	1-15
5.4 TESTING LABORATORIES.....	1-16
APPENDIX A. SITE REPORT FOR AC MAINS REPAIR/INVESTIGATION	1-17
APPENDIX B. AC PIPE CONDITION REPORT	1-18
APPENDIX C. CUT AND PREPARED EDGES INSPECTION	1-20
APPENDIX D. WATER ABSORPTION TEST	1-21
APPENDIX E. PIPE DENSITY TESTS	1-22
APPENDIX F. HYDROSTATIC BURSTING TEST FOR AC PIPES (BENCH TEST)	1-23
APPENDIX G. HYDROSTATIC BURSTING TEST FOR AC PIPES (FIELD TEST)	1-27
APPENDIX H. MEASURING THE DEPTH OF DETERIORATION IN-SITU	1-28

SECTION 1: SCOPE AND GENERAL

1.1 SCOPE

This national specification gives details of sampling and testing procedures that are relevant to the assessment of the condition of asbestos cement water main pipes.

1.2 REFERENCED DOCUMENTS

The following documents have been used in preparing or are referred to in this standard:

Standards:

BS 486:1956	Asbestos Cement Pressure Pipes, (= NZS 285:1959)
BS 486:1973	Asbestos Cement Pressure Pipes
BS EN 512:1995	Fibre-cement products – Pressure pipes and joints
BS 4624:1981	Methods of test for Asbestos-cement building products
BS 8010:2.3:1988	Code of Practice for Pipelines, Section 2.3 – Asbestos cement
NZS 3202:1977	Asbestos cement pressure pipes
AS 1711:1975	Asbestos cement pressure pipes
AWWA C 400:1980	Asbestos cement distribution pipe, 4in through 16in for water and other liquids
ISO 2785:86	Directions for selection of asbestos-cement pipes subject to external loads with or without internal pressure
ASTM C 500:1995	Standard test methods for asbestos-cement pipe

Other references:

Guidelines for the Management & Removal of Asbestos, OSH, (Department of Labour) 1995

Material durability in aggressive ground, D L Barry, CIRIA report 98 - 1983

Watermains: Guidance on assessment and inspection techniques CIRIA report 162 – 1996

Planning the Rehabilitation of Water Distribution Systems – WRc 1989

Pipe materials selection manual – Water Supply, 2nd edition, WRc 1989

Internal Corrosion of Water Distribution Systems - AWWA Research Foundation - 1977

Report No. DWI0122, Deterioration of Asbestos Cement Water Mains – Dept. of the Environment, UK - Sept 1998

Waitakere City - Pipeline condition assessment – Summary report, City Design, June 1998

North Shore City - Pipeline condition assessment – Summary report, City Design, July 1998

1.3 DEFINITIONS

Asbestos Cement (AC)

Asbestos cement is composed of approximately 10-15% asbestos fibres in a matrix of ordinary Portland cement or Portland cement and finely ground silica. The Process for making pipes was refined between 1906 and 1913 by Societa Anonia Eternit Pietra Artificiale of Genoa Italy. The pipes imported from the UK (Everite) in the 1940's, 50's and 60's were composed of asbestos fibres and Portland cement, and were water cured for 8-10 days. AC pipes manufactured in Italy, Australia and New Zealand were steam cured in an autoclave.

Nominal diameter (DN)

A numerical value of the size of pipe which is a convenient round number roughly equal to the manufactured dimension of the pipe internal diameter, in mm.

Outside Diameter (OD)

A numerical value of the mean outside diameter as determined by measuring the circumference of a clean pipe specimen.

Wall Thickness (wt)

This is the numerical value of the wall thickness of the pipe. It is found by measuring the wall thickness at 6 equally spaced intervals around the pipe circumference, (as per 5.2.1 of this specification).

Pipe Pressure Class and Designed Working Pressure (WP)

The pressure class is an alphabetic character that is given to the nominal maximum working pressure of the pipe. The nominal maximum working pressure (WP) is related to the mechanical characteristics of the pipe. The pressure classes for AC pipes used in New Zealand between 1940 and 1986 and their nominal maximum working pressure ratings are shown in table 1 below. The pressure classes for imported pipes were A, B, C and D. Classes E and F were only available in Australia and New Zealand and only available up to DN 150-mm.

Factory Test Pressure (TP)

The TP is the value of the hydrostatic pressure that pipes were subjected to in the factory. Table 1 shows the relationship between the pipe pressure class, the WP and TP for AC pipes.

TABLE 1. CLASSIFICATION OF ASBESTOS CEMENT PIPES

Pipe Pressure Class	Design WP (m head)	Min. TP (m head)
Class A	30	60
Class B	60	120
Class C	90	180
Class D	120	240
Class E	150	300
Class F	180	360

(Note that pipes produced in New Zealand and Australia under the "Fibrolite" brand name were subjected to a proof test pressure of 50% greater than the standard TP requirement).

Bursting Pressure (BP)

The BP is the minimum value of the hydrostatic pressure required to cause failure when a pipe or sample is tested in the factory by a pipe manufacturer. This value varied with pipe diameter and is shown in table 2.

TABLE 2. RELATIONSHIP BETWEEN WORKING, TEST AND BURST PRESSURES

DN (mm)	BP/TP	BP/WP
From 50 to 100	2	4
From 125 to 200	1.75	3.5
From 200 to 600	1.5	3

Field Bursting Pressure (FBP)

This is the pressure at which a specimen of pipe that is (or has been) in service bursts. Such tests can be carried out on a pipeline that has recently been made redundant due to replacement works or has been abandoned. It is not normally advisable to carry out a FBT on an in-service pipeline. The burst pressure found in this test is influenced by external loads imposed on the pipe due to bedding conditions, etc and is usually lower than the BBP.

Bench Bursting Pressure (BBP)

This is the pressure necessary to cause failure of a pipe specimen when bench tested. The results can be higher than the FBP as the pipe is not subjected to any external loads. Also, a "short" bench test sample is unlikely to contain the "extreme value" deterioration that will be present in the much longer length of pipeline that is used for a FBP test.

Water Absorption (WA)

This is the percentage of water, absorbed by the AC pipe wall matrix, expressed as a percentage of the dry mass. As the pipe matrix deteriorates, the amount of water that can be absorbed increases.

Dry Pipe Density (D)

This is the density of the dried pipe wall matrix, expressed in g/ml. This is also a measure of the deterioration of the pipe matrix. There is a fairly good correlation between the *WA* and *D* values.

Saturated Pipe Density (D_s)

This is the density of the saturated pipe matrix, expressed in g/ml. This property can be measured more readily than either *WA* or *D* as there is no need to completely dry the pipe specimen (which may take 48 hours or more).

Phenolphthalein Indicator

A chemical that is dissolved in alcohol to produce a colourless liquid that changes to a magenta colour when painted onto sound cementitious material that has retained its alkaline nature. It is used to assist in identifying the depth of deterioration of freshly cut sections of AC pipe.

SECTION 2 BACKGROUND INFORMATION

2.1 PIPE SAMPLING

Pipe samples may be obtained from opportunistic events, e.g. (mains breaks, repair work, new connections or exposure by another utility) or they may be obtained from a sampling programme devised to investigate the condition of in-service pipes. Where samples are collected as part of a sampling programme, every reasonable effort should be made to ensure that the samples collected are as representative as possible of the majority of the pipeline under consideration.

The following factors need to be considered in selecting sampling locations for an investigation and sampling programme:

Pipe Material Considerations:

- Pipe manufacturer
 - Date of installation
 - Pipe diameter
 - Pipe pressure class
- This information may be available from as-built records and asset databases. Sampling should consider pipe age, diameter and class. Newer pipes, larger diameters and higher-pressure classes can generally be expected to have a greater remaining lifetime. Typical samples should be taken from each of the categories (left).*

Operational Considerations:

- Traffic Control
 - Pedestrian Safety
 - Water Shut-off
- These considerations may require the timing of works to be adjusted to avoid peak traffic, critical consumer demand, etc.*
- Operating pressures
 - Maintenance History
- This information may not be available. Sampling should concentrate on higher pressure and higher failure rate areas.*

Pipe Environment Considerations:

- Bedding & backfilling
 - Soil type
 - Groundwater level
- Sampling should concentrate on heavy clay and peaty soils, areas with poor bedding and high ground water table areas.*

2.2 PIPE SAMPLE SIZE

The size of sample to be recovered for testing will depend on the testing to be carried out. If a BBP test is proposed, the length of the sample will need to be in accordance with Table F1 in Appendix F. Where pressure testing is not to be carried out, the sample should be at least 70 mm in length. (Such short samples will allow the use of stainless steel clamps for repairs, thus minimising the cost of a sampling program). It should be noted that there can be highly variable exterior attack along the pipe and if this is found to be the case, the sample length should be sufficiently long to ensure that it is reasonably representative of the majority of the pipeline.

For non-destructive testing carried out on site, the length of pipe exposed will control the length of pipe that can be assessed.

2.3 BURST FAILURES - PRESSURE RECORD

Where pipes have failed due to over-pressurising, (bursting), as evidenced by a longitudinal split or a section of pipe burst from the pipe wall, a pressure recording should be obtained. This record should be for a period of not less than one week to determine the peak static pressures during the diurnal cycle, as well as the existence of any pressure transients.

The pressure-recording instrument to be used shall be capable of picking up short-lived transients in pressure. A standard water supply pressure transducer and datalogger may not be satisfactory unless the recording interval can be reduced to 5 seconds or less. Note that at this logging interval, the total number of events to be logged can quickly use all of the available storage. An analogue pressure recorder (Vernon and Morris or equivalent) will usually provide a satisfactory result.

The internal pressure in the pipe also has some effect on the crushing or bending failure of pipes. Combined loading, (internal pressure and bending or crushing stresses), has the effect of reducing the stress needed for failure by either pressure or external loads on their own.

2.4 FIELD INSPECTION REPORT

The maintenance contractor (or sampling contractor) should be required to complete a field inspection report for each sample whether it is collected as a result of a pipe repair, burst or as part of a sampling programme. An example of a suitable "site report for mains repair/inspection" record sheet is given in Appendix A. A copy of the field inspection report should accompany each pipe sample that is sent to a laboratory for assessment so that all of the relevant details are kept together.

NOTES:

If filled in correctly and completely, this type of record sheet will have the following benefits in the management of a water reticulation network:

- *Confirming and Updating existing asset records (diameter, material, pressure class)*
- *Providing information on pipe condition for entry into asset records and GIS database*
- *Assisting with planning and prioritising of rehabilitation or renewal works by:*
 - *Monitoring deterioration*
 - *Recording information that can be used to assess costs of repairs*
 - *Recording the seriousness of the fault and the disruption to traffic and consumers*

2.5 FIELD BURSTING PRESSURE

A FBP test may be carried out on any length of pipeline that has been abandoned or made redundant. The cost of this additional testing will be significant but can yield valuable results. The purpose of carrying out such test/s is to provide more information on the actual "in-ground" performance of deteriorated AC pipe. It is necessary to excavate the actual burst site and to carry out an evaluation of the pipe wall matrix at the burst so that the pipe wall condition can be related to the burst pressure.

Bench testing of an adjacent sample of pipe of similar condition will provide data that can be used to relate FBP, BBP and pipe condition results. If sufficient data can be collected, it will be used to confirm pipe failure pressure predicted from observations of deterioration determined by simpler tests.

An FBP test is carried out by selecting a suitable length (or lengths) of pipeline that can be blanked off with a minimum of effort. Some minor leakage is tolerable, provided the rate of pressure loading specified can be achieved. The procedure for an FBP test is given in Appendix G. The number of connections to the main should be limited as much as possible so that the risk of failure of a fitting, e.g. tapping band, nipple or gibault joint, is minimised. If failure of a fitting occurs, the result of the test is invalid and a further test/s will be necessary until pipe failure occurs. It is critical that the pressurising pump has sufficient capacity to raise the pressure smoothly (without pulsations) to the bursting pressure. This pressure can be greater than 5,000 kPa.

2.6 SOIL SAMPLING

AC pipe production ceased in 1984 and most pipes have been in service for at least 17 years. The effects (if any) of aggressive soil and groundwater conditions are therefore well defined, often highly variable and can be measured and assessed after appropriate preparation and treatment of the pipe.

Practical experience has shown that pipes laid in low resistivity soils usually exhibit almost no external deterioration. Pipes that have been laid in heavy clays, organic (peaty) soils or in areas that are subjected to a high or fluctuating water table usually exhibit major deterioration. These observations are confirmed in literature and the following section covers the subject in broad terms. Soil sampling is considered to be unnecessary, as the results of the soil environment are plainly evident on the pipe exterior. The cost of soil analysis and investigation would appear to be more effectively spent on obtaining more pipe samples.

The following general comments are included for guidance if soil sampling is to be undertaken.

The relative aggressiveness of soils has been generalised as follows: (CIRIA Report 98)



The principal parameters that influence natural soil corrosiveness to AC pipes are given below and if soil sampling is undertaken, these four parameters should be measured.

Resistivity – Resistivity is considered to be one of the most important parameters when assessing the corrosivity potential of a soil. Resistivity is a measurement of the voltage drop across a line of current flow within the soil. Soils with low resistivity are considered to be highly corrosive. Soils with high resistivity measurements are deemed to be virtually non-corrosive, although other soil parameters may contribute towards corrosion potential.

Moisture content - The moisture content is largely determined by the soil texture. Clay and organic rich soils have higher moisture contents than most other soils. Soils of higher moisture content are also likely to have higher concentrations of mobile ions and a lower pH than other soils. Moisture contents over 20% are considered to be aggressive.

pH value - In general, as the pH decreases, corrosion rates increase. However, the pH value, in itself, is a poor indicator of aggressiveness.

Sulphates - Sulphates in solution react with cement. The reactions produce a larger volume, inducing cracking and delamination.

Analytical data on soils do not in themselves define potential corrosiveness because there can be numerous physical and chemical factors that combine to create the overall potential problem. There can be large variations in soil types along any pipeline and reasonably large numbers of sampling sites are needed to obtain a reliable assessment of corrosiveness potential.

2.7 HEALTH AND SAFETY CONSIDERATIONS

Asbestos cement pipes are composed of a mixture of Portland cement, asbestos cement fibres and finely ground silica. Any operations involving abrasive cutting or sanding power tools can generate large amounts of dust unless the working surface can be kept flooded with water.

Asbestos fibres are hazardous to health and there has been a well-established link to asbestosis since before 1900. Two forms of cancer are also associated with the inhalation of asbestos fibres, lung cancer and mesothelioma. Particles of asbestos fibre that can cause health problems are small enough to be invisible to the naked eye.

The “Guidelines for the Management and Removal of Asbestos” (Occupational Safety and Health Service 1995), contains measures and procedures for the safe handling and disposal of materials containing asbestos. Asbestos cement pipes are covered under part II of these guidelines – Handling Non-Friable Asbestos. Work practises used to cut AC must be designed to minimise worker exposure to the dust and the spread of asbestos into the surrounding environment. Suitable precautions must be taken to avoid contamination of clothing as contaminated clothing that is taken home can expose the worker’s family to the risk of asbestos related disease.

The Health and safety in Employment Act is also relevant. Measures must be taken to minimise asbestos hazards and employees must be adequately trained to work safely with AC pipes. The other requirements of the Act must also be fulfilled.

Pressure testing of pipe samples will also pose a health hazard. In particular, it is essential to ensure that all air is removed from the section of pipeline being tested. Failure to remove the air can result in an explosive failure of the sample as the trapped air that has been compressed expands violently. The end caps or sections of pipe could be dislodged and the pressure test sample should be shielded or the testing staff should stand well clear of the sample when it is under pressure.

SECTION 3 FIELD INVESTIGATIONS

3.1 SITE REPORT FORM

A site report form, (Appendix A), shall be filled in by the sampling or maintenance contractor for each AC pipe sampling event or repair job. The form shall be completed in as much detail as possible and the year that the pipe was laid determined from as-built records or if this information is unavailable, from other sources, e.g. building permits, subdivision records, contract documentation or local knowledge etc. Any identifying marks (manufacturer, date, pressure class etc) that are found on any part of the exposed pipe should be recorded in the "Pipe exterior condition" field.

A copy of the site report shall be attached to the pipe sample in a sealed plastic bag. The water supply authority should also retain a separate copy.

3.2 SAMPLE COLLECTION

Samples shall be taken as required (or instructed) or according to the nature of the repair to be carried out. For any repair that would normally require two gibault type couplings and a length of pipe to repair, a pipe sample shall be taken. The length of undamaged pipe to be recovered shall be at least 600 mm or 6 - 8 x DN, whichever is the greater. It should be noted that for larger diameter pipes, >DN450, a full pipe length (normally 4 metres for Everite and Fibrolite) may be necessary for a "bench" burst pressure test. The minimum length required depends on the sealing method used - refer to Appendix F. External sealing is preferable for pipes of greater than 250 mm. Italit pipe was supplied in 5-metre lengths and it may be practicable to remove less than a full length.

Note: Where pressure testing is not required, a shorter sample length (as per 2.2) should be removed.

If a repair does not require the removal and replacement of a section of water main, (e.g. a tapping band failure), do not remove a pipe sample unless instructed.

Before removing the pipe sample, mark the top using a spot/strip of Dazzle (or equivalent) paint. Cut the sample from the main and ensure that it is undamaged. If the pipe is damaged in the sampling process, take a further undamaged sample. The sample should be sealed in plastic wrapping (or a suitable bag) to prevent moisture loss.

The sample shall be clearly identified by street address and sampling date using a waterproof pen and "tag" or by directly writing on the pipe and/or plastic wrapping with a permanent marking pen.

3.3 EXCAVATION

The effects of bedding and pipe support on AC pipe can be quite significant. During the excavation process, care should be taken in exposing the pipe so that the type of pipe surround material can be observed and noted, the presence of rocks or other deleterious materials and the presence of voids under the pipe noted. The excavation down to just above the crown of the pipe can be carried out using an excavator, but the pipe itself should be exposed by hand excavation. Comments on the pipe bedding should be recorded in the appropriate field on the left centre of the form. Care should be exercised to avoid damaging the pipe surface.

3.4 HANDLING AND STORAGE

Pipe samples shall be handled with care at all times to ensure that they are not damaged. They shall be stored out of direct sunlight and in a safe storage area. They shall be stacked horizontally and secured against rolling.

When the required numbers of samples have been collected (usually 2 or more) they shall be forwarded to the testing laboratory for evaluation. The time from collection to evaluation shall be kept as short as possible, preferably less than 1 week and definitely not more than 1 month, to ensure that the samples do not dry out.

3.5 BURST FAILURE – PRESSURE RECORD

Where a burst failure has occurred, take a 7-day pressure record at the nearest fire hydrant to the burst site. A Vernon and Morris pressure recorder or suitable pressure transducer and datalogger (see section 2.3). The equipment used shall have its accuracy checked against a calibrated class 1 pressure gauge of an appropriate pressure range, each time it is used.

3.6 SOIL SAMPLING

Soil sampling is considered to be unnecessary. If soil analysis is required, the appropriate tests and sampling procedures will be provided.

3.7 FIELD BURST PRESSURE TESTING

Field burst testing, if undertaken at all, will be carried out as a separate exercise.

SECTION 4 IN-SITU PIPE EVALUATION

A number of non-destructive test methods are available for the evaluation of in-service pipes. These include: Manual and visual assessment of the pipe exterior (using simple hand tools), hardness testing (again using hand held equipment). Radiographic examination is no longer considered to provide meaningful results.

4.1 EXTERIOR DETERIORATION ASSESSMENT

The exterior of the pipe can be exposed and assessed in-situ by any or all of the following means. These tests and procedures are not part of the core tests proposed, but they will give an indication of the condition of the pipe and if carried out along with sampling for laboratory tests will help in confirming their value for future condition evaluations.

4.1.1 Visual observation (using hand tools)

The pipe shall be washed clean and the surface condition inspected. The relative softness or deterioration of the surface can be assessed coarsely with a fingernail. Pipes exhibiting advanced deterioration have a very soft, easily scratched surface and a fibrous appearance.

The surface can be scraped or filed back to undeteriorated AC material. This is evidenced by a colour and hardness change or preferably a colour change in phenolphthalein indicator painted on the surface. The depth of the deterioration can be measured using a straight edge and callipers or by the method described in Appendix H. A number of measurements should be made to arrive at an “average”, although the “extreme value” is the most important.

4.1.2 Barcol hardness

A Barcol hardness tester is hand-held and incorporates a spring-loaded indenter that produces a reading on a gauge when it is pushed into the pipe surface. This is a quick and easy test that is suitable for use on AC pipe. Results have been shown to produce a high degree of scatter and it is necessary to take a large number of readings to obtain meaningful results. The Barcol hardness is an arbitrary value that can be used to highlight pipes that have a “softer” surface and hence a greater degree of deterioration. A test method has not been given in the Appendices for this method, but testing laboratories are familiar with the procedures.

It is important that the pipe has not dried out for this test as the hardness value can be considerably higher for a dry pipe. This technique does not appear to provide any sensitivity when the surface has deteriorated significantly.

4.2 RADIOGRAPHIC EXAMINATION

Radiography produces a photographic image on a film “plate” that shows deterioration as minor variations in image tone. The X-ray source is placed above or alongside the pipe and a photographic plate is placed on the opposite side of the pipe. The radiation passes through the pipe and creates an image on the photographic plate/s. This technique looks at two walls of the pipe and additional radiographs can be made at 90°. This technique can also be used in the laboratory.

Preliminary testing has shown that exposures at 100-130 kV give acceptable results. The interpretation of the X-ray images is difficult and a very bright light source is needed to view the image. Alternatively, the film can be contact printed onto photographic paper but this adds extra expense. Pipes filled with water produce poorer images than empty sections of pipe.

A Gamma ray source can be used to expose the photographic plates, but the image produced is no better than that from X-rays. Due to the potentially harmful nature of the radiation used and the degree of skill necessary to obtain meaningful results, a licensed operator must be used.

Radiography techniques do not appear to produce results that justify the effort and expense.

4.3 LARGE DIAMETER PIPES

In-situ, non-destructive tests are an appropriate method of assessment for large diameter (375mm and greater) pipes. This is due to the high costs of sample recovery. However, it must also be recognised that the consequences of failure of these large diameter transmission mains can be very serious and that the high sampling and testing costs may be fully justifiable.

Core samples can be removed from the pipe (using under-pressure tapping equipment) and the "core" obtained examined for exterior and interior deterioration. The rather limited area of the sample (approximately 50-mm dia or less) will mean that it is unlikely that the "extreme value" deterioration will be found and measured.

SECTION 5 PIPE SAMPLE EVALUATION

5.1 DETAILS TO BE RECORDED

A pipe condition report form shall be completed for each pipe specimen. This form should be attached to a copy of the field inspection report form so that all relevant details are kept together. A suitable AC pipe condition report form is given in Appendix B. The form itemises the data to be recorded for each specimen.

Items 1-5 of the AC pipe condition report form are “core” requirements that shall be carried out on all pipe samples. Items 6-11 are optional tests that do not appear to be cost effective and are not currently used in the Lifetime Prediction Model.

5.2 PIPE CONDITION OBSERVATIONS

5.2.1 Pipe dimensions

The accurate measurement of pipe dimensions is necessary to assist in identification of the pipe pressure class and possibly manufacturer. The dimensions to be measured are the mean outside diameter and wall thickness. Where pipes have become severely deteriorated, the walls may have swelled. In such cases, the dimensions obtained will be greater than the original manufactured values. Alternatively, the flow and any suspended sediment may have scoured a highly softened wall. Reduction in wall thickness is not uncommon in sewer rising mains where the action of H₂S can cause rapid deterioration of the cement.

Pipe OD

The mean outside diameter shall be determined using a circumferential π tape or a thin steel tape wrapped around the wall and the diameter calculated by dividing by π . The OD should be recorded to the nearest 0.1 mm. The pipe wall shall be thoroughly cleaned to remove all extraneous clay, dust or other debris before taking the measurements. Care should be taken to ensure that the cleaning process does not scour the pipe surface. The pipe mean OD may also be obtained by taking the mean of 6 equally spaced measurements made using callipers. (This method is more time consuming than using a π tape and is usually limited to 250 diameter pipes because of the expense and availability of callipers of greater capacity than 300 mm).

Pipe wt

The pipe wall thickness shall be measured at 6 equal- spaced intervals around the pipe to locate the minimum wall thickness. These dimensions may be measured using a slide calliper or ball/anvil micrometer, capable of reading to an accuracy of 0.1 mm (or better). Record the 6 wall thickness results obtained to the nearest 0.1 mm.

5.2.2 Pipe inspection – exterior

Bitumen coating

Pipes imported from the UK (Everite) were all dipped in a bitumen bath at the factory. This coating has been observed to provide significant protection from aggressive ground conditions and conveyed water. Degradation is generally localised around defects in the coating. This observation has been confirmed in Report DWI0122.

Tick the box that is most appropriate and make any other relevant comments in the “other observations” box.

NOTE: Iron/Manganese deposits on the pipe interior can have a similar appearance to a bitumen coating. A petrol (or other appropriate solvent) soaked rag wiped over the surface will identify a bituminous coating by causing it to dissolve.

Surface condition

The most appropriate box/es should be ticked. Samples should arrive sealed in plastic to preserve their in-situ moisture content as well as ensuring that clay soils (from bedding and backfilling) stuck to the pipe wall remain in place.

Some simple hardness tests can be carried out. Severely deteriorated AC can be scratched and removed using a fingernail, especially if the pipe has not been allowed to dry. A more sophisticated hardness test (e.g. Barcol hardness tester) is possible but this device is limited to relatively shallow, surficial deterioration. The nail penetration test described in 5.2.10 below can also give an indication of the structural integrity of the pipe wall.

Surface damage

The presence of surface damage (gouging or grooving) shall be noted and whether the damage appears to be new or may have been caused during installation (or subsequent work). If there is "Old" damage evident and it appears to be associated in any way with pipe failure, this should be recorded.

The depth of damage and surface gouges can usually be assessed using a straight edge and a slide calliper. Measure and record the maximum depth of the damage to the nearest 0.5mm.

Other observations

Any manufacturing defects should be recorded. Any manufacturers markings that are legible enough to assist with pipe identification and the marking colour should also be recorded.

5.2.3 Pipe inspection – interior

Bitumen coating

Tick the box that is most appropriate and make any other relevant comments in the "other observations" box.

Surface condition

The most appropriate box/es should be ticked.

Other observations

Record any other observations about the pipe interior, e.g. obvious manufacturing defects, etc.

5.2.4 Cut and Prepared Edges Inspection

The objective of this test is to identify the thickness of undeteriorated AC remaining in the pipe wall. The extent of the deterioration can be observed and measured on fresh axial and circumferential cuts painted with phenolphthalein indicator. The deterioration of the internal surface of the pipe tends to be fairly uniform both circumferentially and axially. The exception to this is usually associated with the breakdown of the lining in pipes that have been coated with bitumen.

Where the conveyed water is non-aggressive, the interior deterioration may be negligible. Deterioration of up to 8 mm in 27 years has been observed where the water supply is highly aggressive. (Report DWI0122 gives an example of 8-mm in 40 years for aggressive water).

Exterior deterioration can be highly variable. Observations to date have shown the deteriorated layer to vary from less than 0.5mm to over 6mm in a pipe sample only 150mm in length. The “extreme value” rate of deterioration observed to date has been 9.8mm in 38 years.

SAFETY NOTE:

Cutting and preparation of edges of AC pipe can generate significant amounts of dust. Power tools should be avoided unless adequate precautions are taken to minimise the inhalation of the dust. A petrol powered cut-off saw can be used and a stream of water played on to the cutting surface to eliminate dust. The “slurry” generated must be disposed of carefully or when dry, asbestos fibres may become airborne. The use of hand tools and wet sanding (while arduous) reduces dust generation. (Refer also to section 2.7).

5.2.5 Water Absorption

The objective of this test is to determine the amount of water that can be absorbed by the pipe wall. The maximum allowable water absorption for new pipes in the factory was 20%. (We believe that few new pipes would have exceeded 10% absorption). As the pipe deteriorates, so the amount of water that can be absorbed increases. The testing carried out to date does not appear to show any correlation with pipe deterioration or burst pressure test results, consequently, this test has been moved from a “core” requirement to an optional requirement. The test method is fully described in Appendix D.

5.2.6 Pipe Density

There are two densities that can be measured, the density related to either the dry mass of the AC pipe or the saturated pipe mass. These test are potentially a measure of the AC deterioration. The deterioration process results in a lowering of the average density of the pipe wall matrix. However, the results of tests to date show large scatter and do not appear to be worthwhile. The tests are time consuming, requiring an extended drying period that can exceed 48 hours. This test has also been moved from a “core” requirement to an optional requirement. The test methods are fully described in Appendix E.

5.2.7 Bench Burst Pressure (BBP) Test

The objective of the BBP test is to determine the pressure needed to cause failure of a pipe sample tested under controlled conditions on a bench. The failed sample shall be used for the water absorption and pipe density tests above. The testing to date has produced a wide scatter of results that do not provide any degree of confidence and this test has also been moved from a “core” requirement to an optional requirement. The test method is fully described in Appendix F.

5.2.8 Field Burst Pressure (FBP) Test

The objective of the FBP test is to determine the pressure needed to cause failure of a length of pipeline that is buried and thus subjected to the additional external loading associated with bedding and bending stresses. The test method is fully described in Appendix G. No satisfactory results have been obtained to date due to the use of inappropriate pressurising equipment. A field burst pressure test need to be carefully planned and executed using appropriate equipment that can raise the pressure smoothly to the burst pressure which may be considerably greater than 5,000kPa for high pressure class pipes in reasonably-good condition.

5.2.9 Barcol Hardness Test

Refer to section 4.1.2 for details of this test. This test has relatively low sensitivity when the surface has suffered moderate to high levels of deterioration.

5.2.10 Nail Penetration Test

A rather coarse, but quite effective indication of the structural integrity of the pipe wall is provided by attempting to drive a standard 100 x 8 jolt head nail through the pipe wall using a standard claw hammer. If the nail can be driven through the wall, the pipe can be regarded as being near the end of its useful life, especially if penetration is achieved easily. If the nail only penetrates a small distance (a few millimetres) and then bends without penetrating, the pipe wall has significant remaining strength. The nail should be driven into the wall at the area that appears to have the greatest depth of deterioration and if penetration is achieved also at the area of the wall with the least deterioration.

5.2.11 Radiography Test

Refer to section 4.2. The interpretation of the exposed films is difficult and the results do not appear to be reliable. This test method has been dropped from this specification.

5.3 SUMMARY OF CORE AND OPTIONAL TESTS

The following table shows a summary of the data and tests that are considered to be “core” requirements and some additional optional tests.

Description	Core Requirement	Optional Requirement
Site Report (Appendix A)	✓	
Pipe Condition Report (Appendix B)	✓	
1. Operational details	✓	
2. Pipe Dimensions	✓	
3. Pipe Inspection (Exterior)	✓	
4. Pipe Inspection (Interior)	✓	
5. Cut and prepared edges inspection	✓	
6. Water Absorption		✓
7. Pipe Density		✓
8. Bench Burst Pressure		✓
9. Field Burst Pressure		✓
10. Barcol Hardness		✓
11. Nail Penetration		✓

5.4 TESTING LABORATORIES

The following testing laboratories are able to carry out all of the above tests.

Laboratory Name and Contact	Address	Phone
SGS New Zealand Ltd, Auckland – Dean Currie	43 Church Street, Onehunga	09 634 3637
Materials and Quality Consultancy Ltd Christchurch – Dennis Hills	Unit 9, 11 Homersham Place Christchurch	03 358 6199
MPT (Materials Performance Technologies) – Dr Jon Morris	Gracefield Research Centre Gracefield Road Lower Hutt	04 569 0534

APPENDIX A. SITE REPORT FOR AC

MAINS REPAIR/INVESTIGATION

Sample identifier

Reported on

Reported at (Time)

Job and Site Details

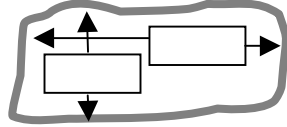
Date of work: <input type="text"/>	Job Code <input type="text"/>	
House No <input type="text"/>	Supply cut off for <input type="text"/> hrs	
Street <input type="text"/>	No. customers off <input type="text"/> Best estimate	
Area/Suburb <input type="text"/>	Traffic Disrupted <input type="checkbox"/> Badly <input type="checkbox"/> Slightly <input type="checkbox"/> No effect	
<i>Sketch of site: (Use back of sheet if necessary)</i> <div style="border: 1px solid black; height: 100px; width: 100%;"></div>	Permanent Reinstatement needed? <input type="checkbox"/> Yes <input type="checkbox"/> No	
Bedding <input type="checkbox"/> Natural <input type="checkbox"/> Sand <input type="checkbox"/> Grit <input type="checkbox"/> Scoria Other: <input type="text"/> Comment <input type="text"/>	Soil Type <input type="checkbox"/> Topsoil <input type="checkbox"/> Clay soil <input type="checkbox"/> Heavy wet clay <input type="checkbox"/> Sand/gravel <input type="checkbox"/> Fill <input type="checkbox"/> Hard rock <input type="checkbox"/> Rotten rock Other: Pipe Cover: <input type="text"/> m	 Surface <input type="checkbox"/> Chip seal <small>size of Patch</small> <input type="checkbox"/> Asphalt <input type="checkbox"/> Concrete <input type="checkbox"/> Paving stones <input type="checkbox"/> Grass berm Other

Reported by:

Employee
 Consumer
 Other, specify:

Failure caused:

Loss of supply
 Low pressure
 No problem
 Damage - *specify*

.....

 Other problems:

Year Pipe Laid
(If known)

Pipe Manufacturer

Other Details

Pipe Diameter	Pipe type	Reason for work	Joint system	Cause of Failure
<input type="checkbox"/> 50	<input type="checkbox"/> Asbestos Cement	<input type="checkbox"/> Pipe sampling	<input type="checkbox"/> Supertite collar	<input type="checkbox"/> Pipe deterioration
<input type="checkbox"/> 80	<input type="checkbox"/> Cast Iron	<input type="checkbox"/> Pipe burst	<input type="checkbox"/> Glued socket	<input type="checkbox"/> Excavator
<input type="checkbox"/> 100	<input type="checkbox"/> CLS	<input type="checkbox"/> Pipe split	<input type="checkbox"/> Gibault joint	<input type="checkbox"/> Thrusting/drilling
<input type="checkbox"/> 150	<input type="checkbox"/> PE -Type? <input type="text"/>	<input type="checkbox"/> Circular crack	<input type="checkbox"/> Rubber ring	<input type="checkbox"/> Tree root
<input type="checkbox"/> 200	<input type="checkbox"/> PVC	<input type="checkbox"/> Tapping Band	<input type="checkbox"/> Unknown	<input type="checkbox"/> Ground Movem't
<input type="checkbox"/> 225	<input type="checkbox"/> MPVC	<input type="checkbox"/> Joint failure		<input type="checkbox"/> Unknown
<input type="checkbox"/> 250	Other:	Other:	Other:	Other:
<input type="checkbox"/> 300				
Other:	Pipe sample taken? <input type="checkbox"/> Yes <input type="checkbox"/> No	<i>Comments on cause of failure:</i> <div style="height: 40px;"></div>		
Sample length: <input type="text"/> m	Pipe OD <input type="text"/> mm			

Repair Details:

Pipe Exterior Condition:

Signed:
Serviceperson

Job Completed	
Date: / /	Time:

Entered on Database/Plans: Filed:

APPENDIX B. AC PIPE CONDITION REPORT

Date of inspection:

Sample identifier

Failure inspection? Yes No

Address

1. Pipe Operational Details

Diurnal Peak pressure m head Surges? Yes No Peak surge pressure m head

Comments:

2. Pipe Dimensions

Pipe wall thickness (6 equally spaced locations)	<input type="text"/>	<input type="text"/>	<input type="text"/>	<input type="text"/>	<input type="text"/>	<input type="text"/>
Pipe minimum wall thickness	<input type="text"/> mm	Comments:				
Mean pipe OD	<input type="text"/> mm					
Pipe DN <input type="text"/> mm	NZ Std OD <input type="text"/> mm	NZ Std min wall thickness	<input type="text"/> mm			

3. Pipe Inspection - Exterior

<i>(Wash, brush or scrape sample clean as necessary)</i>			Other Observations: (Manufacturers markings etc)
Bitumen Coating	Surface condition	Surface damage	
% of surface with sound bitumen coating <input type="text"/> %	<input type="checkbox"/> In-situ moisture <input type="checkbox"/> Dry or near dry <input type="checkbox"/> Soft, (Fingernail) <input type="checkbox"/> Hard	<input type="checkbox"/> None <input type="checkbox"/> Recent damage <input type="checkbox"/> Old damage Depth: mm	

4. Pipe Inspection - Interior *(If no inspection tick here)*

<i>(Wash, brush or scrape sample clean as necessary)</i>		Other Observations:
Bitumen Coating	Surface condition	
% of surface with sound bitumen coating <input type="text"/> %	<input type="checkbox"/> In-situ moisture <input type="checkbox"/> Dry or near dry <input type="checkbox"/> Soft, (Fingernail)	

5. Cut and Prepared Edges Inspection

Ring section cut:		Longitudinal cuts:		Number <input type="text"/>
Exterior	Interior	Exterior of pipe	Interior of pipe	
<input type="checkbox"/> No deterioration <input type="checkbox"/> Minor <input type="checkbox"/> Significant	<input type="checkbox"/> No deterioration <input type="checkbox"/> Minor <input type="checkbox"/> Significant	<input type="checkbox"/> No deterioration <input type="checkbox"/> Minor <input type="checkbox"/> Significant	<input type="checkbox"/> No deterioration <input type="checkbox"/> Minor <input type="checkbox"/> Significant	
Min. depth: <input type="text"/> mm	Min. depth: <input type="text"/> mm	Min. depth: <input type="text"/> mm	Min. depth: <input type="text"/> mm	
Max depth: <input type="text"/> mm	Max depth: <input type="text"/> mm	Max depth: <input type="text"/> mm	Max depth: <input type="text"/> mm	

Other Observations and comments:

6. Water Absorption (Optional) $(= [M_S - M_D] \times 100 / M_D \%)$

Water Absorption (WA) M_S M_D %

7. Pipe Density (Optional) $(= M_D / [M_D - M_I] \text{ g/ml})$

Dry pipe density (D)	<input type="text"/> M_D	<input type="text"/> M_I	(g/ml)
Saturated density (D_S)	<input type="text"/> M_S	<input type="text"/> M_I	(g/ml)

Comments:

8. BBP Test (Bench test – optional)

Specimen O/A length	<input type="text"/> mm	Sealing method:	Internal <input type="checkbox"/>	External <input type="checkbox"/>
Specimen soaked?	<input type="checkbox"/> Yes <input type="checkbox"/> No	Held @ pressure of	<input type="text"/> m head	For <input type="text"/> hrs
Burst Pressure	<input type="text"/> m head	Pressure loading rate	<input type="text"/> m/sec	
<i>Comments on burst:</i>				

9. FBP Test (Field test – optional)

Test length of pipe	<input type="text"/> m	Held @ pressure of	<input type="text"/> m head	For <input type="text"/> hrs
Burst Pressure	<input type="text"/> m head	Pressure loading rate	<input type="text"/> m/sec	
<i>Comments on burst:</i>				

10. Barcol Hardness Test (Optional)

Number of tests (<i>min 10 distributed</i>)	<input type="text"/>	Number of tests (<i>min 10 distributed</i>)	<input type="text"/>
Exterior:		Interior:	
Min. hardness value observed.	<input type="text"/>	Min. hardness value observed.	<input type="text"/>
Max. hardness value observed.	<input type="text"/>	Max. hardness value observed.	<input type="text"/>
Average hardness value	<input type="text"/>	Average hardness value	<input type="text"/>
<i>Comments:</i>			

11. Nail penetration Test (Optional)

Did nail penetrate wall at area of worst deterioration?	Yes <input type="checkbox"/>	No <input type="checkbox"/>
Did nail penetrate wall at area of least deterioration?	Yes <input type="checkbox"/>	No <input type="checkbox"/>
Depth of penetration achieved (mm)	exterior <input type="text"/>	Interior <input type="text"/>
<i>Comments:</i>		

APPENDIX C CUT AND PREPARED EDGES INSPECTION

Procedure

A section of pipe, usually more than 75-mm in length, is cut cleanly at the ends and sliced to expose at least 2 longitudinal cut surfaces. The deterioration of the AC wall matrix can be observed as a colour change. The use of phenolphthalein indicator is recommended in establishing the boundary between the sound and deteriorated cementitious matrix. Undeteriorated asbestos cement has a high pH and turns the colourless phenolphthalein indicator a magenta colour. Where the wall has deteriorated, the indicator remains colourless. UK Department of the Environment report *DW10122* confirms the use of phenolphthalein for this purpose.

The pipe can be cut using hand or power tools, provided adequate precautions are taken to minimise dust generation and eliminate the inhalation of dust. (Refer to sections 2.7 and 5.2.4).

If the surface has been cut for some time and the indicator solution does not change colour, it may be necessary to “freshen” the surface to remove any carbonated layer of cement. This can be done by filing or wet sanding.

The maximum and minimum depth of deterioration (both internally and externally) shall be measured using callipers and recorded to the nearest 0.5mm.

Record the results in the appropriate section of the AC pipe condition report.

Example of 100 dia AC pipe with phenolphthalein indicator

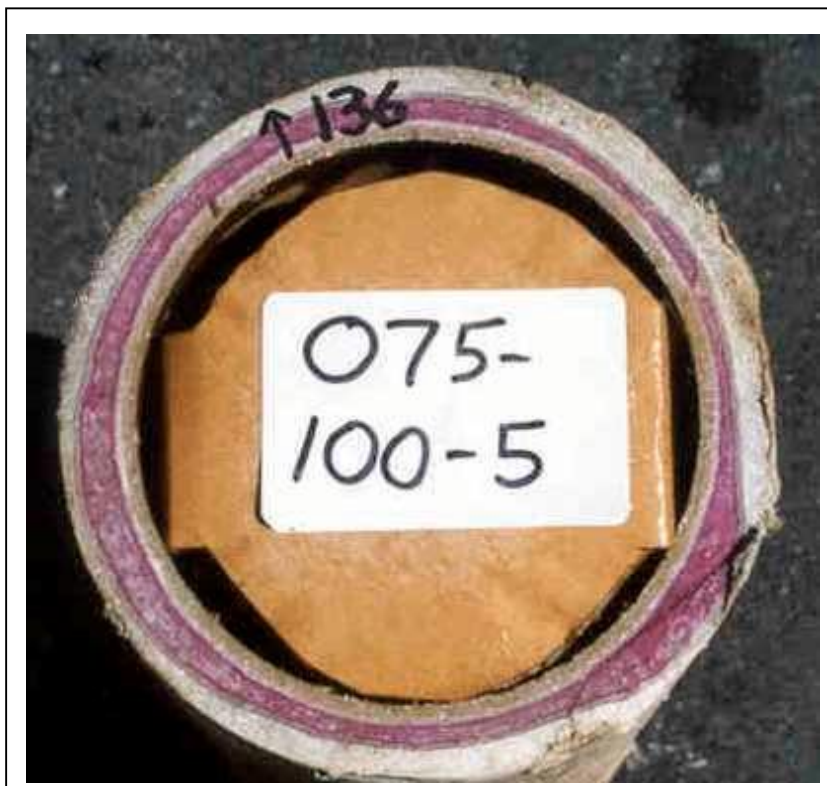

The magenta sections of the wall are sound AC, the light coloured areas have deteriorated. This sample shows rather extreme variability in deterioration externally, and fairly uniform deterioration internally.

APPENDIX D WATER ABSORPTION TEST

(Modified from BS 486:1973 and NZS 3202:1977 to accommodate tests on in-service pipe)

Procedure

The length of the specimen to be tested for water absorption will vary according to the pipe diameter. Part of the pipe that was used for the Bench Burst Pressure test shall be used for this test. The wet weight of the sample should not normally exceed 5 kg (to minimise drying times) but should be more than 2 kg, except in the case of 50 mm pipes which shall be at least 1 kg. (The use of a smaller amount of pipe could allow localised defects to have a significant effect on the results).

The following table gives the approximate lengths of a full pipe sample that are required for this test:

TABLE D1. APPROXIMATE LENGTH OF SAMPLE REQUIRED

Pipe DN (mm)	Approximate length (mm)
50	250 - 350
100	250 - 350
150	100 - 200
200	75 - 150
Larger sizes	2 – 5 kg

The test piece shall be thoroughly scrubbed to remove all traces of clay or other extraneous bedding or organic matter that may be adhering to the pipe wall, both internally and externally. Care should be exercised to avoid removing very soft asbestos material. Part of the pipe that was used for the BBP test shall be used for this test. The test piece/s shall be completely immersed in potable water at not less than 15°C for a period of 24 hours to ensure complete absorption. (A shorter time may be used if it can be shown that the mass of the saturated, surface dry specimen has not changed more than 0.5% between weighing at 1 hour intervals).

Remove surplus moisture with a damp cloth and weigh to find the saturated mass, (M_S). Place the piece/s in a convection oven heated to $150 \pm 5^\circ\text{C}$ and capable of maintaining that temperature. Drying shall continue until the piece assumes constant mass. Checking is done by removing the piece from the oven at intervals, allowing it to reach room temperature before weighing. The last two readings shall be noted and shall show a variation of less than 0.5%. Drying times are dependent on the size of the piece, thickness and oven loading. Weigh the dried specimen and record the dry mass (M_D).

Calculate the water absorption WA as the difference between the mass after immersion in water (M_S) and the mass after drying (M_D) and express the result as a percentage of the dry mass.

$$WA = \frac{(M_S - M_D) \times 100}{M_D}$$

Where

WA water absorption expressed as a percentage of the dry mass of the pipe

M_S is the mass of the saturated, surface dry test piece in g

M_D is the dry mass of the test piece in g

Record the results in the appropriate section of the AC pipe condition report.

APPENDIX E PIPE DENSITY TESTS

(Modified from BS 4624:1981 to accommodate tests on in-service pipe)

NOTES

The deterioration process results in a lowering in the average density of the pipe wall matrix. It appears that there is a reasonable correlation between water absorption and density and it may be possible to substitute the density test for the water absorption test; however, both tests require saturating and drying the pipe.

Procedure (dry density - D)

Part of the pipe that was used for the Bench Burst Pressure test (preferably the same specimen as used for the water absorption test) shall be used. The test piece shall be thoroughly scrubbed to remove all traces of clay or other extraneous bedding or organic matter that may be adhering to the pipe wall, both internally and externally. Care should be exercised to avoid removing very soft asbestos material.

The test piece should be immersed in potable water until it is saturated (usually for a minimum of 24 hours). It is then weighed while immersed and again after wiping the surface dry, in air. The volume in ml is the difference between the mass (g) in air and the mass (g) immersed, ($M_S - M_I$). Determine the dry mass (M_D) of the sample by drying in an oven (refer to Appendix D).

Calculate the density using the formula:

$$D = \frac{M_D}{(M_S - M_I)}$$

Where

D is the dry density in g/ml

M_S is the mass of the saturated, surface dry, test piece in g

M_I is the immersed mass of the saturated test piece in g

M_D is the dry mass of the test piece in g

Procedure (saturated density - D_s)

The masses obtained in the dry density test should be used.

Calculate the density using the formula:

$$D_s = \frac{M_s}{(M_s - M_I)}$$

Where

D_s is the saturated density in g/ml

M_s is the mass of the saturated, surface dry, test piece in g

M_I is the immersed mass of the saturated test piece in g

Record the results in the appropriate section of the AC pipe condition report.

APPENDIX F HYDROSTATIC BURSTING TEST FOR AC PIPES (BENCH TEST)

(Modified from BS 486:1973, NZS 3202:1977 and BS EN 512:1995, to accommodate tests on in-service pipe)

NOTES

The general procedure for determining the hydrostatic burst pressure as detailed in the referenced standards is not considered to be appropriate for testing in-service pipe specimens. Some clarification of the procedure is necessary and the length of sample to be used is fairly critical. The minimum sample length given in BS 486:1956, AS 1711:1975 and NZS 3202:1977 is considered to be too short to provide reliable results. BS 486:1973 increased the length required and BS EN 512:1995 increased it still further. The minimum length required by this test procedure is given in Table F1.

The relativity between burst pressure for a pipe specimen bench tested and field failures/burst tests is affected by a number of factors and conditions that are difficult to simulate in a bench test. These factors include:

- Bedding and backfilling support or lack of support
- Bending loads generated by ground settlement
- Point loads due to bedding and backfilling, traffic etc
- Non-typical specimen of pipe
- Combined loading, i.e. internal pressure and external loads

End restraint effects can have a significant effect on the burst pressure of a bench test specimen. End effects can be eliminated by using internal sealing devices, however, a number of different diameter mandrels may be needed to accommodate the variability of pipe wall thickness. Using an external sealing device will result in some external restraint that will reinforce the specimen ends and shorten the effective length of the specimen under test, (by approximately two pipe diameters). The variation in external diameter can be accommodated using Viking Johnson MaxiStop or MaxiDaptor fittings or their Dresser equivalents.

The use of end plates with gaskets compressed against prepared ends of the pipe is believed to provide end restraint on the specimen and the compressive stress imparted to the pipe will affect the burst pressure and is therefore inappropriate. (Refer to BS 486:1973 which states "...avoiding as far as possible any axial compression of the pipe").

The rate of pressure loading should reflect as closely as possible the loading rate experienced in the reticulation system due to normal closure of a fire hydrant or other event e.g. malfunctioning pressure reducing valve, solenoid valve controlled industrial processes, pump start and stop cycles or power failure.

Sample length

The minimum sample length to be used shall be as shown in the following table.

TABLE F1. MINIMUM LENGTH OF SAMPLE REQUIRED

Pipe DN (mm)	Minimum test specimen length (mm)	
	With internal seal	With external seal
50 - 100	600	600 + 2xDN
> 100	6xDN	8xDN or full pipe length

Procedure

The test piece/s shall be completely immersed in potable water at not less than 15°C for a period of 24 hours to ensure complete absorption. (A shorter time may be used if it can be shown that the mass of the saturated, surface dry specimen has not changed more than 0.25% between weighing at 1 hour intervals).

After immersion, subject the test piece to internal hydrostatic pressure in a rig of the types illustrated in Figures 1 and 2. (Alternative methods of sealing and restraint may be acceptable provided they do not impart compressive stress into the pipe wall).

Slowly raise the hydrostatic pressure in the pipe to the peak operating pressure (using a suitable pressure pump) and hold at that pressure for 5 - 10 minutes. Ensure that all air has been expelled and commence the test by raising the pressure at a rate of 0.15 - 0.3 MPa/second until failure occurs. (If other accurate data on the actual loading rates that are found in the water main are available, these loading rates should be used). Refer to section for section 2.7 for safety requirements.

The bursting pressure shall be measured using a calibrated class 1 pressure gauge fitted with a stop pointer to indicate the pressure at which failure occurs. Alternative means of measuring and recording the bursting pressure will be acceptable, provided that they can record the actual burst pressure to an equivalent or better accuracy e.g. pressure transducer and appropriate datalogger.

After bursting, the relevant data shall be recorded in the appropriate section of the AC pipe condition report. The burst pipe specimen shall also be tested in accordance with Appendices C, D & E to determine its condition and the extent of deterioration.

FIGURE 1: (Internal sealing method)

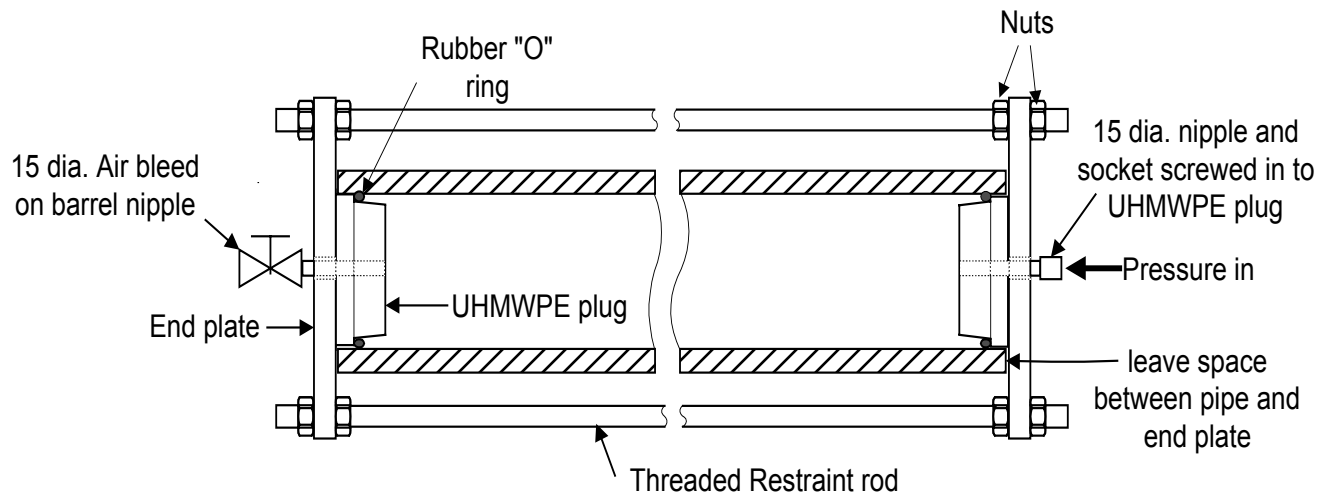

TABLE F2. RIG REQUIREMENTS (Allows for pressures up to 8.5 MPa for pipes up to 150 dia)

Pipe DN	No of restraint rods	Bolt dia. Grade 8.8	End Plate thickness	External seal		Internal seal	
				End plate OD	Bolt PCD	End plate OD	Bolt PCD
50-100	3	M12	20	300	240	210	155
150	4	M16	24	365	305	270	210
200	4	M16	30	430	370	320	260
250	4	M16	40	500	430	390	320

In order to minimise the sizes and number of bolts required, four M16 grade 8.8 bolts would cover pipes up to 250 diameter. The use of threaded rods will allow flexibility of test specimen length. Suitable threaded rod is available in grade 8.8 steel, in 2 metre lengths.

Several end plates of different OD and thickness could be used to minimise the weight when testing smaller pipes.

A range of end plugs and elastomer sealing rings will be necessary to accommodate the various pipe diameters and pressure classes. The OD of the plugs needed is given in Table F3. The use of UHMWPE (ultra high molecular weight polyethylene) is recommended, but any suitable corrosion resistant material could be used. Elastomeric sealing rings can be customised to suit by cutting and gluing suitable diameters of rubber with super glue.

TABLE F3. PLUG OD's

Pipe DN	OD of Plug (mm)			
	Class B	Class C	Class D	Class E
50	48	48	48	48
55	55	55	55	55
80	72	72	72	67
100	98	93	93	86
150	151	143	138	136
200	200	192	183	NA

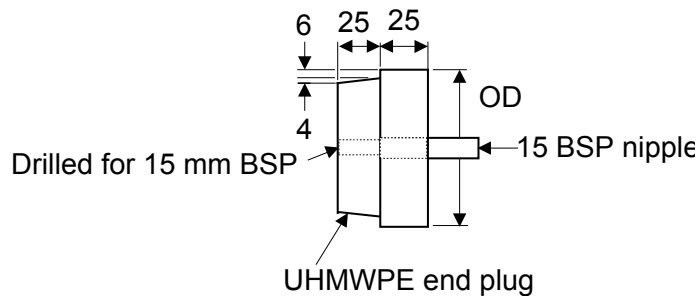
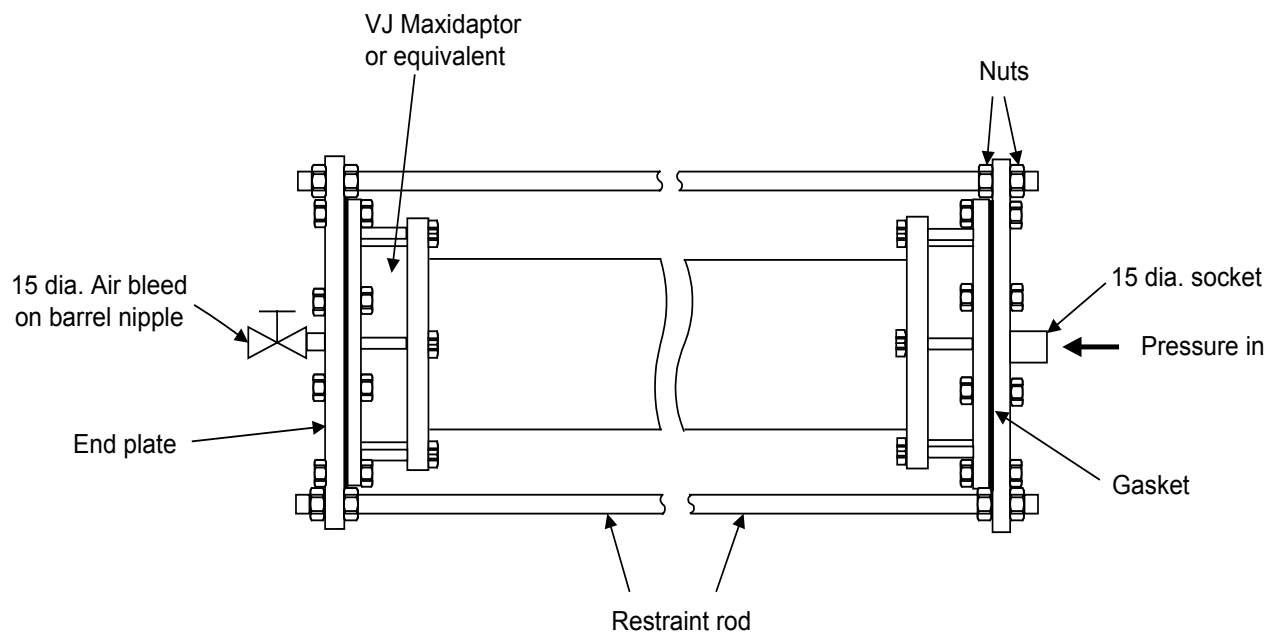

FIGURE 2: (External sealing method)



Large Diameter Pipes

Pipes of larger diameters will require larger restraint rods and thicker end plates. The number of tests to be carried out on pipes of greater than 300 mm nominal diameter will probably mean that the cost per test will be disproportionately high. Evaluation by other means may be preferable, e.g. in-situ tests as outlined in section 4.3, and/or cut-out samples evaluated for deterioration only as per Appendix C.

Table F4 shows the number and diameter of the restraint rods needed to hold end caps in place for pipes of 300 mm diameter and larger. The end caps and end plates will need to be specifically designed. The restraint rod lengths needed may make it necessary to use much thicker mild steel rods.

TABLE F4. RESTRAINT ROD REQUIREMENTS FOR PIPES OF 300 AND LARGER

Pipe DN	No of restraint rods	Rod dia. (Grade 8.8)
300	6	M16
375	6	M16
450	6	M20
525	6	M20
600	6	M20

APPENDIX G. HYDROSTATIC BURSTING TEST FOR AC PIPES (FIELD TEST)

Test length

The test length may be as short as one to two pipe lengths and may be 40 metres (or more) and selected to take account of the following:

- Minimum disruption to the public during the test
- Smallest number of old connections and fittings that may fail or have to be plugged
- Lowest cost of surface reinstatement on completion, i.e. berm areas preferably.

Blanking off

The test section shall be isolated using gibault blank caps or an equivalent. The caps shall be anchored securely to resist the pressure generated. This may be achieved by tomming back to the existing pipe with hardwood chocks. Provision should be made to bleed off any air trapped in the system (this can be achieved by loosening the end caps during the initial pressurising).

Pressure Test

Slowly raise the hydrostatic pressure in the length of main to the “normal” operating pressure (using a hose connected to the main supply) and hold at that pressure for 5-10 minutes. Ensure that all air has been expelled and commence the test by raising the pressure smoothly (using a suitable pressure pump), at a rate of 150-300 kPa/second until failure occurs. (If other accurate data on the actual peak loading rate that is found in the water main is available, then this loading rate should be used). The pump to be used must be capable of raising the pressure smoothly to the burst pressure that could be in excess of 5,000 kPa. Pumps that produce pressure pulsations should not be used.

The bursting pressure shall be measured using a calibrated class 1 pressure gauge fitted with a stop pointer to indicate the pressure at which failure occurs. Alternative means of measuring and recording the bursting pressure will be acceptable, provided that they can record the actual burst pressure to an equivalent or better accuracy e.g. pressure transducer and appropriate datalogger.

After bursting, the relevant data shall be recorded in the appropriate section of the AC pipe condition report. The site of the burst shall be excavated and the burst section of pipe removed for examination in accordance with Appendices C, D & E to determine its condition and the extent of deterioration. A section of undamaged pipe, (of the length required for a BBP test), shall be taken from the same pipe that failed (if this is possible) and an additional sample taken from an adjacent pipe. Both of these samples shall be subjected to a BBP test as per Appendix F.

Comments

This test procedure has been included so that Authorities can carry out the test if the opportunity presents itself. It is recognised that most Authorities will not be in a position to undertake this type of test, but the results obtained will be more representative of the pipeline’s burst pressure than the BBP test.

There is a possibility that the failure could occur prematurely at a pipe fitting and the result be invalid. This can be overcome by re-siting the end cap and carrying out a further test/s.

It may be difficult to locate the site of the burst and this may require the provision of a temporary connection to an adjacent fire hydrant and running water until the burst can be located by surface evidence or ultrasonic sounding.

Refer to section 2.7 for safety issues. It is possible to completely cover the end caps with sand to eliminate virtually all risk.

APPENDIX H. MEASURING THE DEPTH OF DETERIORATION IN-SITU

The depth of deterioration can be measured directly from a cut and prepared surface, using callipers. This is not possible in a field situation.

The pipe can be filed with a flat mill file until the sound AC matrix is located. By painting the cut surface with phenolphthalein indicator, the undeteriorated material will be obvious. The width of the “cut” at that point (c), can be used to calculate the depth of the deteriorated AC, using the diagram and formulae below

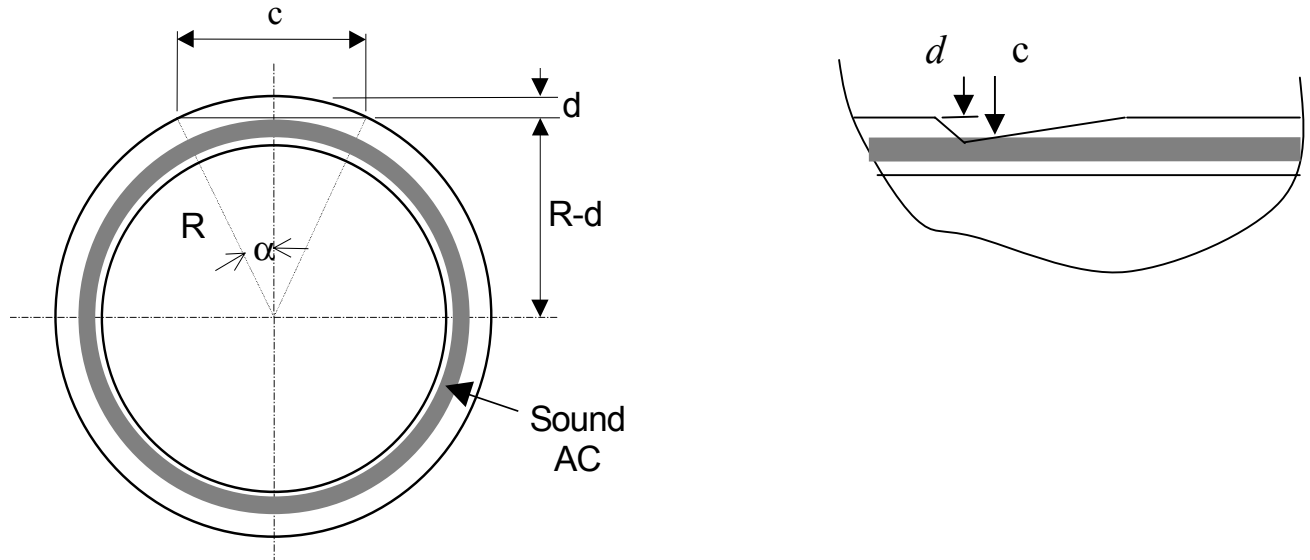

The depth of deterioration can be calculated from the following formula. [It is necessary to measure the pipe OD and the width of the “cut” (c)].

$$\alpha = \text{Sin}^{-1} \frac{c}{2R}$$

$$d = R - (R \text{Cos} \alpha)$$

Where:

c	=	Width of cut
d	=	Depth of deteriorated layer
R	=	Pipe OD/2
α	=	Half of angle at centre

The depth d can also be measured directly using callipers and a straight edge. A set of plastic callipers can be glued to a suitable straight edge and the depth of the deteriorated layer measured using the depth gauge.

Precautions

The file must be held flat as there is a danger of “rocking” the file and thus over-estimating the width C.

The filing must be carried out with extreme care to avoid removing a significant amount of the undeteriorated AC material with the possibility of causing pipe failure. This operation should only be carried out by someone who has experience in pipe sample evaluation.

	PAGE
1 INTRODUCTION	2-1
2 DATABASE AND MODEL DEVELOPMENT	2-1
2.1 NATIONAL DATABASE	2-1
2.2 DETERIORATION MODEL	2-2
2.3 LIFETIME PREDICTION MODEL	2-2
2.4 LIFETIME PREDICTION CHARTS	2-4
2.5 VARIABILITY OF DETERIORATION RATES (LIFETIME PREDICTION CHARTS)	2-4
3 DATABASE AND MODEL APPLICATION	2-5
3.1 MASTER DATABASE AND MODEL	2-5
3.2 WORKING DATABASE AND MODEL	2-5
3.3 LIFETIME PREDICTION CHARTS	2-7
4 NOTES ON LIFETIME PREDICTIONS AND RENEWAL PROGRAMMING	2-8

1 INTRODUCTION

This document introduces the user to the National AC Watermain Database and Lifetime Prediction Model. It covers the development and application of the various parts of the database and model.

The National AC Watermain Database and Lifetime Prediction Model has been developed to provide Water Supply Authorities with a tool for estimating the lifetime for AC watermains. The information obtained from this database and model is intended to be used in asset management applications such as the programming of pipeline replacements.

The database and model has been developed in four sections that record data from AC pipe sample appraisals, then use the data to predict lifetimes for pipes. The four sections are:

- *The National Database*: records pipe appraisal results from around the New Zealand.
- *The AC Watermain Deterioration Model*: uses data from the National Database to develop a relationship between pipe age and total deterioration.
- *The Lifetime Prediction Model*: predicts “years to deterioration failure” for samples of pipes that have been appraised in accordance with the National Specification for Sampling and Testing of Asbestos Cement Watermains.
- *The Lifetime Prediction Charts*: for predicting “years to deterioration failure” for pipes, based on the pipe age, size and operating pressure. These charts are intended to be used for pipelines that have had no pipe condition assessment samples taken.

2 DATABASE AND MODEL DEVELOPMENT

2.1 National Database

The National Database is designed to record information obtained from appraisals of AC pipe samples (as set out in the National Specification for Sampling and Testing). While a wide range of appraisal results can be entered into the database, there is a selection of core information that is required so that the results can be used by the other parts of the database and model. This core information is:

- Pipe size (mean outside diameter)
- Installation date (year)
- Appraisal date (year)
- Peak operating pressure (m)
- Minimum pipe wall thickness (mm)
- Maximum internal deterioration (mm)

Maximum external deterioration (mm)

The National Database is updated as new pipe appraisal results are received.

2.2 Deterioration Model

The Deterioration Model uses the information from the National Database to develop a relationship between pipe age and total pipe deterioration. This relationship is assumed to be linear (see Figure 1), primarily because the sample data obtained thus far does not justify the use of another type of relationship. The relationship developed by the Deterioration Model represents the average total deterioration rate (mm/year) of the samples that have been assessed. This average deterioration rate is used in the Lifetime Prediction Model (see Section 2.3) and the Lifetime Prediction Charts (see Section 2.4).

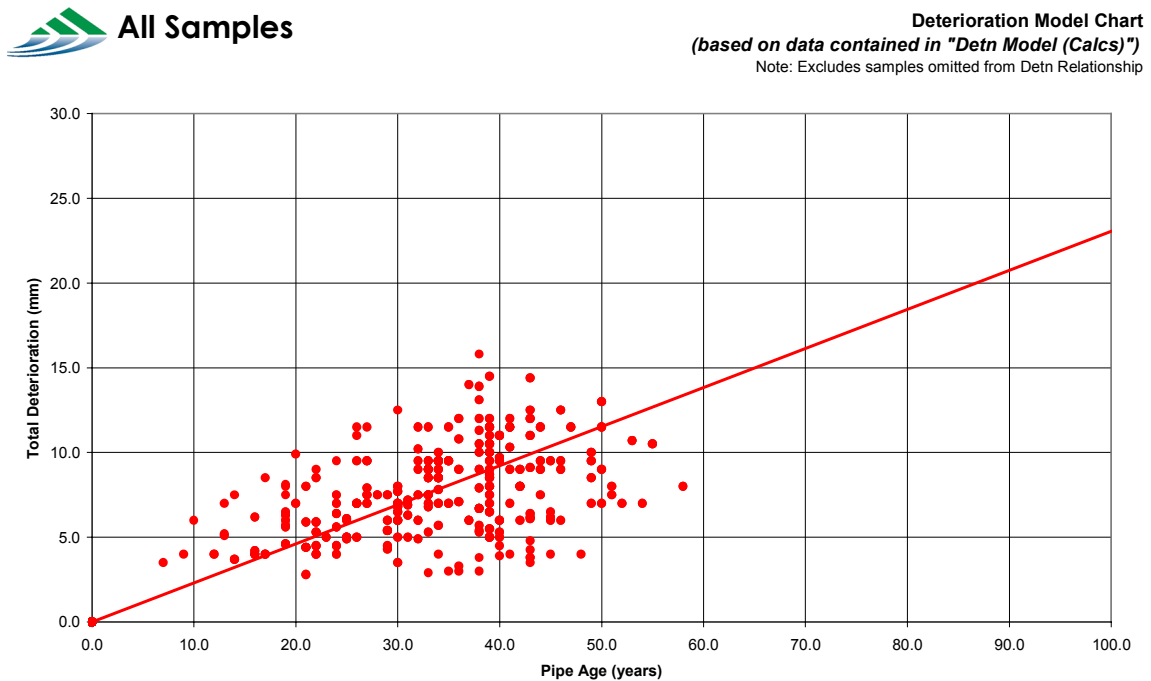

Figure 1: Average Deterioration Relationship

For practical reasons, the Deterioration Model is only updated after 50 new AC appraisal results are entered into the National Database or after 1 year has passed since the last update. There are currently 250 AC pipe appraisal results used by the Deterioration Model.

2.3 Lifetime Prediction Model

The Lifetime Prediction Model uses the individual pipe sample appraisal results contained in the National Database and predicts the “years to deterioration failure” for each pipe.

The lifetime predictions are made using the deterioration scenario described in Figure 2. The critical assumption is that from the time the AC pipe is laid, internal and external factors begin to deteriorate the pipe wall matrix at a CONSTANT RATE. This rate is the total deterioration divided by the sample age (this information is recorded during appraisal).

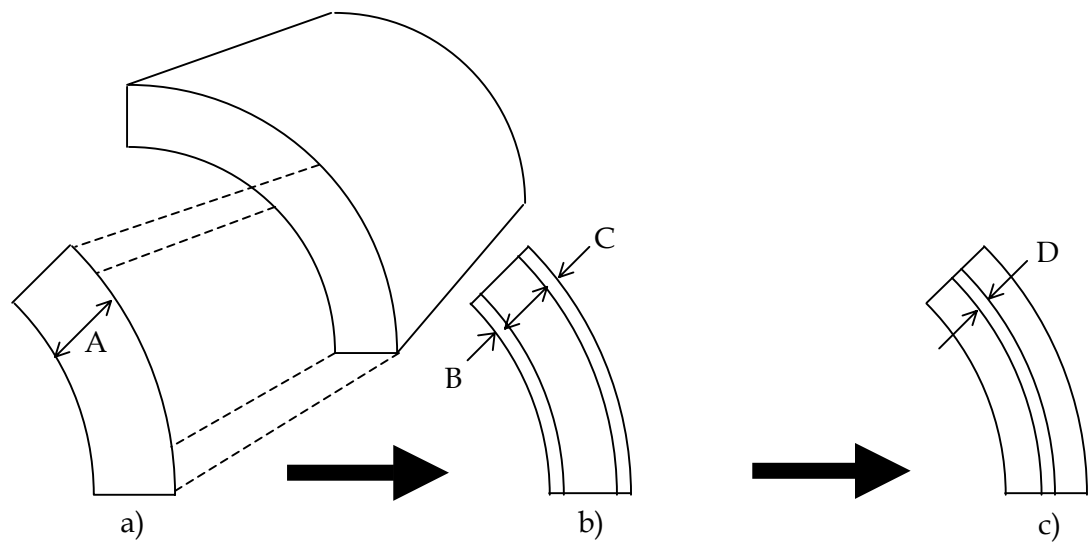

Figure 2: Assumed Deterioration Scenario

- a) When the pipe is first laid it is assumed that there has been no deterioration of the wall. This assumption cannot be made if pipe had been stored for an extended period in an area exposed to rainfall. (Soft rainwater is relatively aggressive to asbestos cement pipe).
- b) When a pipe is sampled and appraised during its lifetime, the internal deterioration (dimension B) and the external deterioration (dimension C) are recorded and combined to give the TOTAL pipe deterioration. The total deterioration observed is assumed to have occurred at a constant rate from when the pipe was first laid.
- c) The end of an AC pipe lifetime is assumed to be the point in time when the thickness of undeteriorated pipe wall equals the “theoretical minimum undeteriorated wall thickness” (dimension D). This thickness is calculated from pipe material properties, dimensions and operating pressure using the Barlow equation. The actual year that this wall thickness is reached is calculated using the individual sample deterioration rate calculated at the time of sample appraisal.

Note: the Lifetime Prediction Model does not predict pipe lifetimes greater than 100 years. This is because the failure mechanisms of AC pipe beyond this age are unknown and possibly quite variable.

The Model compares individual sample deterioration rates with the national average AC deterioration rate. This gives the user an indication of whether their pipes are deteriorating faster or slower than the national average rate.

A default surge factor of 1.5 times the peak operating pressure is used in the Model to allow for pressure surges in the network. Where comprehensive pressure records that extend over a significant time period and cover all of the operating conditions in a network are available, these records may allow for a lower surge factor to be used. The peak operating pressure is defined as the static pressure obtained by subtracting the pipe elevation from the top water level in the reservoir or the steady pumping pressure in the main. This value will change along a pipeline as the elevation of the ground changes.

2.4 Lifetime Prediction Charts

The Lifetime Prediction Charts have been developed to allow the prediction of lifetimes for pipelines that have not had sample appraisals carried out. The charts use the standard minimum wall thickness plus 1mm for each pipe size and pressure class and the average deterioration rate from the Deterioration Model.

Lifetime Prediction Charts have been produced for the following pipe sizes and pressure classes:

- 50 mm (class E/F)
- 80 mm (class A/B, C/D and E/F)
- 100 mm (class A/B, C/D and E/F)
- 150 mm (class A/B, C, D, E and F)
- 200 mm (class A, B, C and D)
- 225 mm (class A, B, C and D)
- 250 mm (class A, B, C and D)
- 300 mm (class A, B, C and D)
- 375 mm (class A, B and C)

Guidance on the use of the Lifetime Prediction Charts is contained in Section 3.3.

Note: the Lifetime Prediction Charts also use the surge factor of 1.5 to account for pressure surges in the network.

2.5 Variability of Deterioration Rates (Lifetime Prediction Charts)

The scatter of results in Figure 1 shows the variability in AC pipe deterioration rates. This variability is partially due to the effects that local conditions have on the deterioration rate of AC pipes. These conditions include:

- Local groundwater and soil characteristics
- Local potable water characteristics
- Pipe installation quality (e.g. damage to bitumen coating)

The Lifetime Prediction model accounts for these local conditions by using the individual sample deterioration rates in generating each lifetime prediction. The Lifetime Prediction charts use the national average deterioration rate.

Charts showing the variability in deterioration rates have been included for various AC pipe sizes and common pressure classes. These charts highlight the variability of pipe deterioration rates and serve to show that prediction of individual pipeline lifetimes using the national average could result in premature replacement of a pipeline.

Charts have been prepared for the following pipe sizes and common pressure classes:

- 50 mm (class E/F)
- 80 mm (class C/D)
- 100 mm (class C/D)
- 150 mm (class C)
- 200 mm (class C)
- 225 mm (class C)
- 250 mm (class C)
- 300 mm (class C)
- 375 mm (class C)

3 DATABASE AND MODEL APPLICATION

The Database and Model consists of three parts.

3.1 Master Database and Model

The “Master Database and Model” can only be altered by the model and database caretaker (currently Opus International Consultants in Christchurch) and can't be used for generating lifetime predictions from new AC appraisal results.

The purpose of the Master Database and Model is to maintain a record of all AC appraisal results and use them to update the Deterioration Model used by the Working Model and Database and the Lifetime Prediction Charts.

Updates of the Master Database and Model are carried out as follows:

- New AC appraisal results are entered as the model and database caretaker receives them. Lifetime predictions are also generated at the same time.
- The Deterioration Model is updated after 50 new AC appraisal results have been entered or after 1 year has passed since the last update.
- The Working Version and Lifetime Prediction Charts are updated when the Deterioration Model is updated (i.e. after 50 new AC appraisals have been entered or after 1 year has passed since the last update).

3.2 Working Database and Model

The “Working Database and Model” is a simplified version of the Master Database and Model in that it contains only a small “database” and a working lifetime prediction model. The deterioration rate is fixed within the Working Database and Model until the next update is released.

Note: The Working model and database uses a default surge factor of 1.5 to account for pressure surges within the network. This value can be “user defined” by manually entering a value as a function of the peak operating pressure. Users are cautioned against using a lower multiplier unless solid evidence is available to support the use of a lower value.

The Working Model allows the user to enter new AC appraisal results and generate lifetime predictions. This is done in 3 steps:

- 1) Open the “Update Information” worksheet to ensure that the Working Version is current. Also, an alternative value for the pressure surge multiplier may be entered.
- 2) Enter a new appraisal result(s) in the “Database” worksheet using one of ten “New Result” rows (see Figure 4). Two example entries are provided to assist the user.



Local Authority	Location Description	City/Town	Pipe DN (mm)	Mean Pipe OD (mm)	Min. Pipe Wall Thickness (mm)	Pipe Specific Gravity	Working Pressure (MPa)	Max. External Det'n (mm)	Max. Internal Det'n (mm)	Total Det'n (mm)	Water Absorp. P (%)	Det'n Burst Press. (MPa)	Average Est. Burcol Hardness	Average Int. Burcol Hardness	Year of Installation	Year of Appraisal	Sample Age
Example 1	Street 1	Town 1	100	127.0	11.7	1.98	0.5	2.0	1.0	3.0	7.9	0.25	40	30	1961	1999	38
Example 2	Street 2	Town 2	100	124.1	11.0	1.56	0.7	3.0	2.5	6.5	24.6	0.25	40	0	1960	1999	39
New Result 1	Location Description	City/Town	DN	OD	WT	SG	Pressure	Ext Det'n	Int Det'n	#VALUE!	WA	BEP	Ext BH	Int BH	Installed	Appraised	#VALUE!
New Result 2	Location Description	City/Town	DN	OD	WT	SG	Pressure	Ext Det'n	Int Det'n	#VALUE!	WA	BEP	Ext BH	Int BH	Installed	Appraised	#VALUE!
New Result 3	Location Description	City/Town	DN	OD	WT	SG	Pressure	Ext Det'n	Int Det'n	#VALUE!	WA	BEP	Ext BH	Int BH	Installed	Appraised	#VALUE!
New Result 4	Location Description	City/Town	DN	OD	WT	SG	Pressure	Ext Det'n	Int Det'n	#VALUE!	WA	BEP	Ext BH	Int BH	Installed	Appraised	#VALUE!
New Result 5	Location Description	City/Town	DN	OD	WT	SG	Pressure	Ext Det'n	Int Det'n	#VALUE!	WA	BEP	Ext BH	Int BH	Installed	Appraised	#VALUE!
New Result 6	Location Description	City/Town	DN	OD	WT	SG	Pressure	Ext Det'n	Int Det'n	#VALUE!	WA	BEP	Ext BH	Int BH	Installed	Appraised	#VALUE!
New Result 7	Location Description	City/Town	DN	OD	WT	SG	Pressure	Ext Det'n	Int Det'n	#VALUE!	WA	BEP	Ext BH	Int BH	Installed	Appraised	#VALUE!
New Result 8	Location Description	City/Town	DN	OD	WT	SG	Pressure	Ext Det'n	Int Det'n	#VALUE!	WA	BEP	Ext BH	Int BH	Installed	Appraised	#VALUE!
New Result 9	Location Description	City/Town	DN	OD	WT	SG	Pressure	Ext Det'n	Int Det'n	#VALUE!	WA	BEP	Ext BH	Int BH	Installed	Appraised	#VALUE!
New Result 10	Location Description	City/Town	DN	OD	WT	SG	Pressure	Ext Det'n	Int Det'n	#VALUE!	WA	BEP	Ext BH	Int BH	Installed	Appraised	#VALUE!

Enter new appraisal results here

Figure 4: Entering new AC appraisal results into the Working Model – Database Worksheet

- 3) Switch to the “Lifetime Prediction Model” worksheet, which has automatically generated a lifetime prediction for the appraisal results just entered. The lifetime prediction will appear in the same row as the corresponding appraisal result. A comparison of the sample deterioration rate with the latest national average deterioration rate is also generated.



Input from National Data Base for Asbestos Cement Watermain Assessment										Calculations Based on Sample Data			Deterioration Model Output			Lifetime Prediction Model Output	
Local Authority	Location Description	City/Town	Pipe DN (mm)	Mean Pipe OD (mm)	Min. Pipe Wall Thickness (mm)	Working Pressure (MPa)	Total Det'n (mm)	Year of Installation	Year of Appraisal	Sample Age (Years)	Working Pressure Surge (MPa)	Mainline Deterioration Rate (mm/yr)	Int'l Det'n Corrosion Failure (mm)	Sample Det'n Rate (mm/yr)	Ratio of Sample to National Average	Estimated Pipe Life (Years)	Estimated Year of First Det'n Failure
Example 1	Street 1	Town 1	100	127.0	11.7	0.5	3.0	1961	1999	38	0.05	2.1	16.6	0.079	0.4	100	2001
Example 2	Street 2	Town 2	100	124.1	11.0	0.7	6.5	1960	1999	39	0.19	1.7	5.3	0.067	0.3	50	2009
New Result 1	Location Description	City/Town	DN	OD	WT	Pressure	#VALUE!	Installed	Appraised	#VALUE!	#VALUE!	#VALUE!	#VALUE!	#VALUE!	#VALUE!	#VALUE!	#VALUE!
New Result 2	Location Description	City/Town	DN	OD	WT	Pressure	#VALUE!	Installed	Appraised	#VALUE!	#VALUE!	#VALUE!	#VALUE!	#VALUE!	#VALUE!	#VALUE!	#VALUE!
New Result 3	Location Description	City/Town	DN	OD	WT	Pressure	#VALUE!	Installed	Appraised	#VALUE!	#VALUE!	#VALUE!	#VALUE!	#VALUE!	#VALUE!	#VALUE!	#VALUE!
New Result 4	Location Description	City/Town	DN	OD	WT	Pressure	#VALUE!	Installed	Appraised	#VALUE!	#VALUE!	#VALUE!	#VALUE!	#VALUE!	#VALUE!	#VALUE!	#VALUE!
New Result 5	Location Description	City/Town	DN	OD	WT	Pressure	#VALUE!	Installed	Appraised	#VALUE!	#VALUE!	#VALUE!	#VALUE!	#VALUE!	#VALUE!	#VALUE!	#VALUE!
New Result 6	Location Description	City/Town	DN	OD	WT	Pressure	#VALUE!	Installed	Appraised	#VALUE!	#VALUE!	#VALUE!	#VALUE!	#VALUE!	#VALUE!	#VALUE!	#VALUE!
New Result 7	Location Description	City/Town	DN	OD	WT	Pressure	#VALUE!	Installed	Appraised	#VALUE!	#VALUE!	#VALUE!	#VALUE!	#VALUE!	#VALUE!	#VALUE!	#VALUE!
New Result 8	Location Description	City/Town	DN	OD	WT	Pressure	#VALUE!	Installed	Appraised	#VALUE!	#VALUE!	#VALUE!	#VALUE!	#VALUE!	#VALUE!	#VALUE!	#VALUE!
New Result 9	Location Description	City/Town	DN	OD	WT	Pressure	#VALUE!	Installed	Appraised	#VALUE!	#VALUE!	#VALUE!	#VALUE!	#VALUE!	#VALUE!	#VALUE!	#VALUE!
New Result 10	Location Description	City/Town	DN	OD	WT	Pressure	#VALUE!	Installed	Appraised	#VALUE!	#VALUE!	#VALUE!	#VALUE!	#VALUE!	#VALUE!	#VALUE!	#VALUE!

Lifetime predictions will appear here

Figure 5: Generating lifetime predictions using the Working Model – Lifetime Prediction Model Worksheet

To enter additional appraisal results use additional “New Result” rows or simply overwrite the result entered in step 1. Up to ten appraisal results can be entered at any one time.

Note: the Working Database and Model will not predict a pipe lifetime greater than 100 years. This is because the failure mechanisms of AC deterioration beyond this age are unknown and possibly quite variable.

3.3 Lifetime Prediction Charts

The “Lifetime Prediction Charts” have been developed to allow the user to make lifetime predictions for pipelines that have not been sampled and appraised.

The Lifetime Prediction Charts use the deterioration rate from the Master Database and Model. This rate is fixed within the Lifetime Prediction Charts until the next update is released (see Section 3.1 for details on when updates are released).

Note: The Lifetime Prediction Charts use a surge factor of 1.5 to account for pressure surges within the network.

When using the Lifetime Prediction Charts, it is necessary to:

- 1) Know the following information about the pipeline in question:
 - Installation date
 - Pipe diameter and pressure class
 - Peak operating pressure
- 2) Use the specific chart for the pipe diameter and pressure class to determine the “predicted years to deterioration failure”. Add this number to the installation date to determine the “year of deterioration failure”.

Example: A 150 mm class C pipe installed in 1967 with a peak operating pressure of 80m head, the “Predicted Years to Deterioration Failure” is 55, giving a “Year of Predicted Deterioration Failure” of 2022 (see annotated Figure 6).

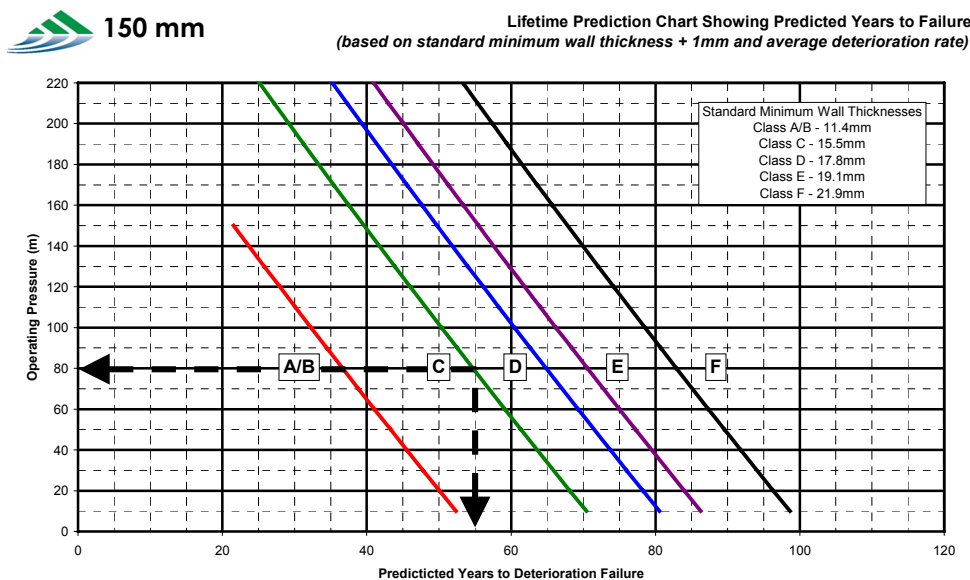

Figure 6: Annotated lifetime prediction chart showing a lifetime prediction using the example in step 2.

- 3) The range in predicted lifetimes can be assessed by using the additional charts detailed in Section 2.5. Sampling of pipelines prior to programming replacement is strongly recommended to provide more confidence in the predictions given by the charts.

Example: For the previous example, the “Years to Deterioration Failure” could vary from 31 years to 103 years (see annotated Figure 7).

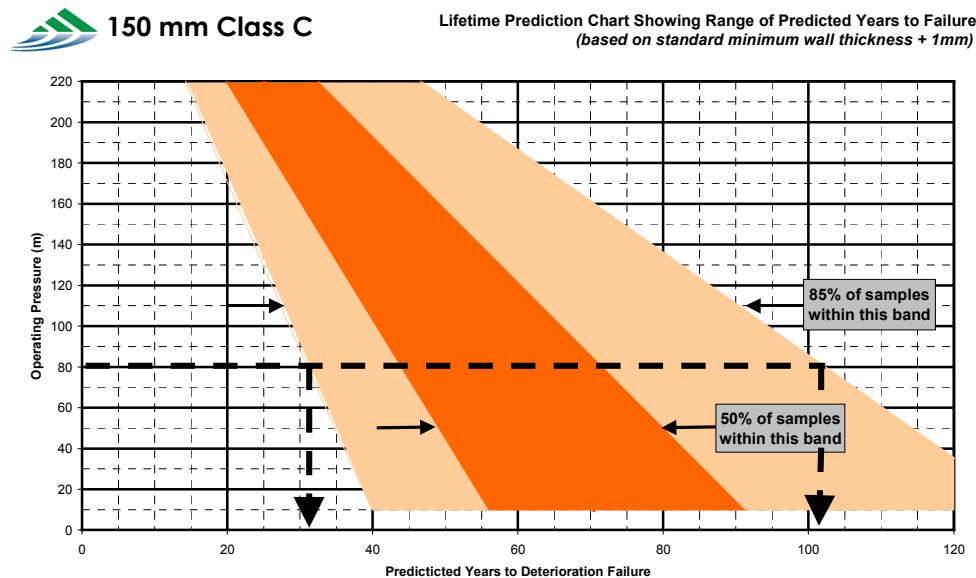

Figure 7: Annotated chart showing the range of lifetime predictions possible

Note: it is not recommended to predict a pipe lifetime greater than 100 years when using the Lifetime Prediction Charts. This is because the mechanisms of AC deterioration beyond this age are unknown and possibly quite variable.

4 NOTES ON LIFETIME PREDICTIONS AND RENEWAL PROGRAMMING

The charts and the model produce a generally conservative average lifetime. This is partly because some of the assessments have been carried out on failed pipe samples and these can be expected to produce a worst-case result. In addition, the deteriorated pipe generally has some residual strength. Well-consolidated bedding and back-filling will also provide some resistance to internal pressures.

It is important that the real cause of failures is identified. If failures due to causes other than deterioration are taken as deterioration failures, this could lead to premature replacement of a pipeline. Deterioration failures are generally predictable, whereas failures due to other causes can be virtually random events. Failures may be due to other causes that may not be directly related to pipe deterioration (e.g. localised sections of pipeline with poor pipe laying/bedding, localised settlement or ground instability, specific pipe fitting failure, excessive and preventable pressure surges, etc). In such cases, failure of the

pipeline may continue at an unacceptable rate that could require pipeline replacement, even although the pipe itself may not be seriously deteriorated.

Renewal programming should take such factors into account and where possible the cost of possible mitigation measures should be balanced against the cost of pipe renewal. For example, it may be that the replacement of a malfunctioning pressure reducing valve, the reduction of operating pressure or the use of soft or variable speed motor starters on pumps could extend the pipeline lifetime at a relatively small cost. Replacement of poor quality fittings should also be considered if fitting failure (e.g. corrosion of malleable iron tapping bands) is the cause of pipe failure.

It is sometimes possible to target pipeline renewal at specific sections of pipelines (e.g. where ground instability is a problem, deterioration is more pronounced (due to aggressive soil or groundwater conditions), or where topography results in high operating pressures).

Some other factors that can cause or contribute to pipeline failure include:

- Loss of pipe bedding support (due to third party operations) – usually highly localised and not normally a cause for total replacement.
- Ground movement (e.g. settlement, slips, earthquakes) – again may be localised and not normally a cause for total replacement.
- Earth pressures caused by wetting/drying of expansive clays – may be localised or quite widespread along a pipeline.
- Unusual pipe loads (e.g. earthmoving or construction traffic, reduced cover etc) – usually localised and not normally a cause for total replacement.
- Growth of tree roots exerting pressure on pipes.
- Excessive pressure surges caused by failure of control systems, incorrect operation of valves or pumps, etc – usually preventable by changing management practices.
- Pipe manufacturing defects.



MASTER DATABASE AND MODEL

SECTION 3

CONTENTS

	PAGE
DATABASE & MODEL REVISION STATUS.....	3-1
DATABASE & MODEL STATISTICS	3-2
NATIONAL DATABASE.....	3-3
DETERIORATION MODEL CALCULATIONS	3-9
DETERIORATION MODEL CHART- ALL SAMPLES	3-13
LIFETIME PREDICTION MODEL.....	3-14
SAMPLE DATA – SUMMARY OF OBSERVED MINIMUM PIPE WALL THICKNESS	3-20

LIFETIME PREDICTION CHARTS

50mm Diameter Pipe

- Chart Calculations	3-26
- Lifetime Prediction Chart	3-27
- Variable Deterioration Chart Calculations	3-28
- Lifetime Prediction Chart Showing Range (50mm Class E/F)	3-29

80mm Diameter Pipe

- Chart Calculations	3-30
- Lifetime Prediction Chart	3-31
- Variable Deterioration Chart Calculations	3-32
- Lifetime Prediction Chart Showing Range (80mm Class C/D)	3-33

100mm Diameter Pipe

- Chart Calculations	3-34
- Lifetime Prediction Chart	3-35
- Variable Deterioration Chart Calculations	3-36
- Lifetime Prediction Chart Showing Range (100mm Class C/D).....	3-37

150mm Diameter Pipe

- Chart Calculations	3-38
- Lifetime Prediction Chart	3-39
- Variable Deterioration Chart Calculations	3-40
- Lifetime Prediction Chart Showing Range (150mm Class C)	3-41

200mm Diameter Pipe

- Chart Calculations 3-42
- Lifetime Prediction Chart..... 3-43
- Variable Deterioration Chart Calculations 3-44
- Lifetime Prediction Chart Showing Range (200mm Class C) 3-45

225mm Diameter Pipe

- Chart Calculations 3-46
- Lifetime Prediction Chart 3-47
- Variable Deterioration Chart Calculations 3-48
- Lifetime Prediction Chart Showing Range (225mm Class C) 3-49

250mm Diameter Pipe

- Chart Calculations 3-50
- Lifetime Prediction Chart 3-51
- Variable Deterioration Chart Calculations 3-52
- Lifetime Prediction Chart Showing Range (250mm Class C) 3-53

300mm Diameter Pipe

- Chart Calculations 3-54
- Lifetime Prediction Chart..... 3-55
- Variable Deterioration Chart Calculations 3-56
- Lifetime Prediction Chart Showing Range (300mm Class C) 3-57

375mm Diameter Pipe

- Chart Calculations 3-58
- Lifetime Prediction Chart 3-59
- Variable Deterioration Chart Calculations 3-60
- Lifetime Prediction Chart Showing Range (375mm Class C) 3-61

NOTE: THE DATA IN THIS SECTION ARE INCLUDED IN THE FILE NAMED DATABASE AND MODEL (MASTER VERSION)



Database and Model Statistics

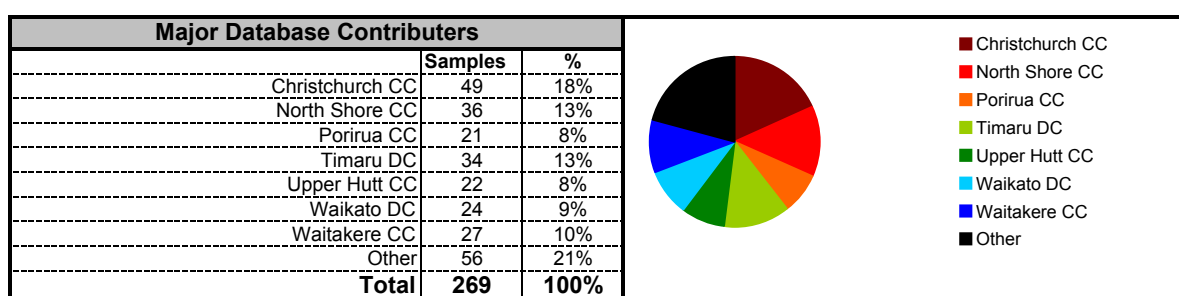
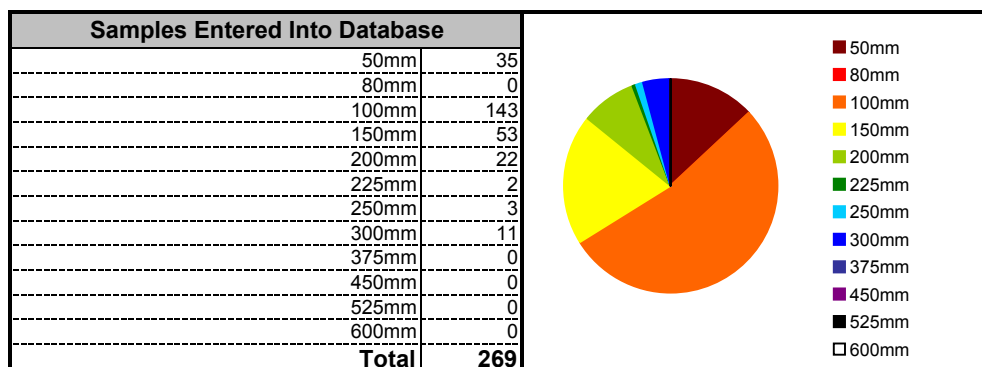

Samples used in Deterioration Model	
50mm	35
80mm	0
100mm	130
150mm	51
200mm	18
225mm	2
250mm	3
300mm	11
375mm	0
Sample data questionable (omitted from relationship)	8
Total	250

Samples used in Deterioration Charts	
50mm	35
80mm	0
100mm	130
150mm	51
200mm	18
225mm	2
250mm	3
300mm	11
375mm	0
Total	250

Samples with Lifetime Predictions	
50mm	35
80mm	0
100mm	143
150mm	53
200mm	22
225mm	2
250mm	3
300mm	11
375mm	0
Total	269



Local Authority	Location Description	City/Town	Pipe DN (mm)	Mean Pipe OD (mm)	Min. Pipe Wall Thickness (mm)	Pipe Specific Gravity	Working Pressure (m)	Max. External Def'n (mm)	Max. Internal Def'n (mm)	Total Def'n (mm)	Water Absorp. (%)	Bench Burst Press. (m)	Average Ext. Barcol Hardness	Average Int. Barcol Hardness	Year of Installation	Year of Appraisal	Sample Age
Ashburton DC	John St	Ashburton	100	128.2	18.3	-	56	2.0	5.0	7.0	11.4	-	20	0	1969	1999	30
Ashburton DC	Thompson St	Ashburton	100	123.0	11.5	-	55	3.0	4.0	7.0	15.0	-	45	0	1969	1999	30
Ashburton DC	Trevors Rd	Ashburton	100	123.0	11.2	-	61	3.0	3.0	6.0	8.3	-	5	0	1969	1999	30
Ashburton DC	Bryant St	Ashburton	150	178.5	12.2	-	59	5.0	4.0	9.0	13.9	-	15	0	1965	1999	34
Ashburton DC	Farm Rd	Ashburton	150	179.9	12.3	-	45	3.0	5.0	8.0	13.1	-	90	0	1969	1999	30
Ashburton DC	McKailly St	Ashburton	200	235.7	15.9	-	55	4.5	2.5	7.0	10.6	-	1	8	1973	1997	24
Carterton DC	Carterton	Carterton	100	124.4	16.9	-	67	5.0	9.0	14.0	-	-	-	-	1960	1997	37
Christchurch CC	Ayr Street	Christchurch	100	127.0	17.7	1.98	58	2.0	1.0	3.0	7.9	826	20	30	1961	1999	38
Christchurch CC	Bryndley Street	Christchurch	100	124.1	11.0	1.56	47	3.0	3.5	6.5	24.6	215	40	0	1960	1999	39
Christchurch CC	Euston Street	Christchurch	100	126.2	17.5	1.98	58	3.0	5.5	8.5	6.6	1037	35	30	1950	1999	49
Christchurch CC	Hansons Lane	Christchurch	100	128.0	18.2	1.84	48	1.0	7.0	8.0	14.4	525	56	0	1960	1999	39
Christchurch CC	Hinua Place	Christchurch	100	125.0	13.5	-	72	3.0	3.5	6.5	9.2	368	-	-	1950	2001	51
Christchurch CC	87 Hollis Avenue	Christchurch	100	123.5	14.0	-	46	2.5	2.0	4.5	-	738	-	-	1986	2001	15
Christchurch CC	114 Hollis Avenue	Christchurch	100	123.5	14.0	2.04	46	2.5	2.5	5.0	-	721	-	-	1986	2001	15
Christchurch CC	Hood Street	Christchurch	100	127.5	17.7	2.04	70	4.0	3.0	7.0	4.6	835	30	30	1945	1999	54
Christchurch CC	Hooker Avenue	Christchurch	100	126.8	17.0	2.02	40	2.0	4.5	6.5	6.2	771	30	21	1960	1999	39
Christchurch CC	Kibblewhite Street	Christchurch	100	127.0	18.0	1.79	68	7.0	1.0	8.0	3.6	646	5	30	1949	2000	51
Christchurch CC	Knowles Street	Christchurch	100	130.3	18.1	2.04	54	7.5	4.5	12.0	6.3	701	30	40	1947	1999	52
Christchurch CC	Maia Street West	Christchurch	100	127.0	17.6	1.68	72	3.0	4.0	7.0	13.1	-	30	42	1950	2000	50
Christchurch CC	Nelson Street	Christchurch	100	127.0	18.0	1.67	72	7.0	6.0	13.0	14.4	-	22	30	1950	2000	50
Christchurch CC	Ocean View Terrace	Christchurch	100	119.0	14.7	1.66	66	3.5	2.5	6.0	15.8	520	43	30	1953	1999	46
Christchurch CC	Poynder Ave	Christchurch	100	123.0	13.1	1.83	40	5.0	4.5	9.5	12.3	671	45	0	1960	1999	39
Christchurch CC	Straven Road	Christchurch	100	123.8	13.0	1.83	41	3.5	5.0	8.5	14.2	564	55	1	1965	1999	34
Christchurch CC	Takeha Drive	Christchurch	100	123.0	12.6	1.83	41	2.0	2.0	4.0	15.1	632	-	-	1955	2001	46
Christchurch CC	Tul Street	Christchurch	100	125.0	13.4	1.89	40	5.0	4.0	9.0	11.4	463	25	42	1955	1999	44
Christchurch CC	Tyrone Street	Christchurch	100	123.0	11.1	1.75	40	3.0	4.0	7.0	18.1	413	1	32	1965	1999	34
Christchurch CC	Waiki Street	Christchurch	100	124.5	11.8	1.61	51	0.5	4.0	4.5	25.4	18	16	1960	2000	40	
Christchurch CC	Clyde Road	Christchurch	150	181.0	12.5	1.51	40	1.5	3.0	4.5	23.9	253	52	5	1975	1999	24
Christchurch CC	Creke Road	Christchurch	150	179.0	15.8	-	51	6.0	6.0	12.0	12.1	387	0	0	1960	2001	41
Christchurch CC	Gilberthorpes Road	Christchurch	150	179.3	11.6	1.73	35	2.0	5.5	7.5	16.9	256	63	0	1948	1999	51
Christchurch CC	Hardwicke Street	Christchurch	150	180.3	15.4	2.05	70	2.5	3.5	6.0	6.2	609	68	45	1980	1999	19
Christchurch CC	Low Street	Christchurch	150	180.8	17.7	1.70	72	3.0	3.0	6.0	19.5	-	30	20	1960	2000	40
Christchurch CC	Lydia Street	Christchurch	150	180.4	16.5	2.01	40	5.0	3.5	8.5	7.1	567	40	60	1982	1999	17
Christchurch CC	Maitpo Street	Christchurch	150	181.5	20.8	1.98	58	6.5	3.0	9.5	8.0	529	10	25	1950	1999	49
Christchurch CC	Rawson Street	Christchurch	150	178.0	18.7	-	72	1.0	0.5	1.5	7.0	447	-	-	1940	2001	61
Christchurch CC	Waimiri Road	Christchurch	150	180.5	16.2	1.63	40	6.0	5.0	11.0	20.0	463	25	0	1960	1999	39
Christchurch CC	Waimiri Road	Christchurch	150	181.1	16.7	1.86	40	6.0	3.0	9.0	8.3	520	40	60	1977	1999	22
Christchurch CC	Waimiri Road	Christchurch	200	230.0	20.7	-	55	6.0	6.0	12.0	9.0	-	-	-	1960	2001	41
Christchurch CC	Avonhead Road	Christchurch	200	234.0	15.6	1.70	40	3.5	3.5	9.5	7.9	443	0	30	1966	2000	34
Christchurch CC	Belfast Road	Christchurch	200	235.0	19.9	1.76	70	1.5	6.0	7.5	6.9	-	60	0	1972	2000	28
Christchurch CC	Byron Street	Christchurch	200	233.9	18.7	1.84	63	5.0	4.0	9.0	11.3	506	22	37	1966	1999	33
Christchurch CC	Centford Street	Christchurch	200	234.0	18.6	-	87	3.0	4.5	7.5	-	513	-	-	1940	2001	61
Christchurch CC	13 Curries Road	Christchurch	200	233.0	18.5	-	87	4.0	4.5	8.5	-	499	-	-	1940	2001	61
Christchurch CC	36 Curries Road	Christchurch	200	237.0	16.5	1.78	40	4.0	4.0	8.0	17.6	191	8	20	1979	2000	21
Christchurch CC	Fendallon Road	Christchurch	200	231.5	19.7	2.05	48	0.5	4.0	4.5	5.1	547	50	40	1977	1999	22
Christchurch CC	Hollis Avenue	Christchurch	200	234.7	15.4	-	65	3.0	4.8	7.8	-	-	-	-	1966	2000	34
Christchurch CC	Main South Road Templeton P Stalon	Christchurch	200	236.0	20.1	1.97	38	3.0	4.0	7.0	7.3	420	38	42	1966	1999	26
Christchurch CC	Queenspark Drive	Christchurch	200	236.0	20.0	1.98	50	3.0	4.0	7.0	7.1	553	25	15	1958	1999	41
Christchurch CC	Spings Road	Christchurch	200	236.0	20.0	1.98	50	3.0	3.5	6.5	4.9	40	40	30	1955	2000	45
Christchurch CC	Station Road	Christchurch	200	234.0	19.4	1.75	40	3.0	3.0	6.0	4.3	515	30	50	1947	1999	52
Christchurch CC	Emmett Street	Christchurch	225	262.0	28.9	2.04	70	3.0	4.0	7.0	4.3	-	-	-	1947	1999	52



Local Authority	Location Description	City/Town	Pipe DN (mm)	Mean Pipe OD (mm)	Min. Pipe Wall Thickness (mm)	Pipe Specific Gravity	Working Pressure (m)	Max. External Def'n (mm)	Max. Internal Def'n (mm)	Total Def'n (mm)	Water Absorp. (%)	Bench Burst Press. (m)	Average Ext. Barcol Hardness	Average Int. Barcol Hardness	Year of Installation	Year of Appraisal	Sample Age
Christchurch CC	Aynsley Terrace	Christchurch	300	346.0	27.2	1.97	70	3.5	5.0	8.5	7.7	535	35	0	1977	1999	22
Christchurch CC	Darrock street	Christchurch	300	339.5	18.6	1.95	40	3.5	5.0	8.5	8.2	391	60	57	1965	1999	34
Christchurch CC	Hills Road	Christchurch	300	344.0	25.1	2.08	70	2.5	3.0	5.5	4.7	565	61	48	1960	1999	39
Christchurch CC	St Asaph Street	Christchurch	300	347.5	27.2	2.05	70	2.5	5.0	7.5	4.7	493	58	15	1970	1999	29
Christchurch CC	Waiweti Street	Christchurch	300	347.0	19.0	1.66	51	2.0	5.0	7.0	13.1	45	25	0	1965	2000	35
Christchurch CC	Watts Road	Christchurch	300	339.0	18.2	1.83	42	2.0	6.0	8.0	10.5	213	58	0	1960	1999	39
Christchurch CC	Watts Road	Christchurch	300	339.0	18.2	1.83	42	2.0	6.0	8.0	10.5	213	58	0	1960	1999	39
Far North DC	140 Commerce St	Kaitiaki	100	124.3	15.9	1.77	72	7.7	2.3	10.0	-	-	-	-	1960	1998	38
Far North DC	194 Commerce St	Kaitiaki	100	122.4	17.1	-	72	9.7	4.2	13.9	-	-	-	-	1960	1998	38
Far North DC	Farrington St	Kaitiaki	100	127.9	17.6	-	72	9.8	6.0	15.8	-	-	-	-	1960	1998	38
Far North DC	Puckey Ave (Int. Taate St)	Kaitiaki	100	126.0	17.3	-	71	9.4	3.7	13.1	-	-	-	-	1960	1998	38
Far North DC	195 Commerce St	Kaitiaki	150	179.7	15.9	-	72	3.5	1.8	5.3	-	-	-	-	1960	1998	38
Far North DC	44 Commerce St	Kaitiaki	150	179.8	21.3	-	72	6.4	4.9	11.3	-	-	-	-	1960	1998	38
Gore DC	Oiauna Water Scheme	Gore	100	124.0	12.9	-	76	4.4	3.5	7.9	-	-	-	-	1972	1999	27
Hauraki DC	Paeroa	Paeroa	300	349.0	23.2	-	75	6.5	5.0	11.5	10.0	-	-	-	1958	1999	41
Hauraki DC	Paeroa	Paeroa	300	349.0	24.0	-	60	7.0	5.0	12.0	-	-	-	-	1958	1999	41
Hauraki DC	Paeroa	Paeroa	300	352.5	24.6	-	74	6.5	5.0	11.5	9.1	-	-	-	1958	1999	41
Hauraki DC	Dome Street	Paeroa	100	124.0	12.9	-	42	5.0	5.5	10.5	-	-	-	-	1962	2000	38
Invercargill CC	Hainsdale Street	Invercargill	100	124.5	13.3	-	50	7.5	4.5	12.0	-	-	-	-	1962	2000	38
Invercargill CC	Islington Street	Invercargill	100	133.5	18.0	-	40	4.5	0.0	4.5	-	-	-	-	1941	2000	59
Invercargill CC	Jack Street	Invercargill	100	123.0	11.0	-	42	7.0	4.0	11.0	-	-	-	-	1957	2000	43
Invercargill CC	Jack Street	Invercargill	100	123.0	11.0	-	42	7.0	4.0	11.0	-	-	-	-	1957	2000	43
Invercargill CC	Miller Street	Invercargill	100	125.0	16.3	-	45	7.0	4.5	11.5	-	-	-	-	1956	2000	44
Invercargill CC	Mersey Street	Invercargill	150	183.0	17.5	-	55	4.0	5.0	9.0	-	-	-	-	1959	2000	41
M o E	Sample 1 (Fire Hydrant)	Casebrook Int. Sch.	100	124.0	11.4	-	40	3.0	0.5	3.5	-	-	-	-	1969	1999	30
M o E	Sample 2 (Main Driveway)	Casebrook Int. Sch.	100	124.0	11.1	-	40	0.5	3.0	3.5	-	-	-	-	1969	1999	30
North Shore CC	Camiot Pl	Glenfield	50	74.5	12.1	1.66	110	4.6	3.5	8.1	31.0	819	-	-	1979	1998	19
North Shore CC	Halberg St	Glenfield	50	71.3	11.0	1.54	110	6.5	3.7	10.2	32.0	698	-	-	1966	1998	32
North Shore CC	Halberg St	Glenfield	50	72.1	11.2	1.61	110	6.1	5.4	11.5	31.0	727	-	-	1966	1998	32
North Shore CC	Hauraki Cres	Glenfield	50	71.7	11.0	1.60	80	5.7	1.1	6.8	33.0	596	-	-	1965	1998	33
North Shore CC	Hillside Rd	Glenfield	50	69.5	9.9	1.44	80	6.4	3.5	9.9	41.0	539	-	-	1976	1998	20
North Shore CC	Nea Rd	Glenfield	50	72.2	11.6	1.76	110	3.5	1.8	5.3	25.0	882	-	-	1965	1998	33
North Shore CC	Stenaway St	Glenfield	50	72.3	11.2	1.82	110	3.5	1.4	4.9	24.0	616	-	-	1966	1998	32
North Shore CC	Sudan Ave	Milford	50	71.8	10.8	1.52	80	7.4	3.4	10.8	37.0	581	-	-	1962	1998	36
North Shore CC	Waiau St	Torbay	50	71.0	10.8	1.57	90	3.8	1.1	4.9	23.0	821	-	-	1973	1998	25
North Shore CC	Waitemata Rd	Takepuna	50	73.0	11.5	1.88	80	4.3	2.6	6.9	23.0	819	-	-	1967	1998	31
North Shore CC	Weldene Ave	Glenfield	50	75.5	13.0	1.68	110	3.8	0.5	4.3	25.0	717	-	-	1969	1998	29
North Shore CC	Weldene Ave	Glenfield	50	75.0	13.1	1.74	110	4.0	0.5	4.5	22.0	938	-	-	1969	1998	29
North Shore CC	Weldene Ave	Glenfield	50	75.0	13.2	2.00	110	4.8	0.6	5.4	18.0	823	-	-	1969	1998	29
North Shore CC	Felicity Pl	Glenfield	100	123.4	13.8	2.77	110	3.5	0.5	4.0	19.0	602	-	-	1991	1998	17
North Shore CC	Garnier St	Glenfield	100	124.0	13.6	2.58	110	4.2	2.2	6.4	15.0	377	-	-	1974	1998	24
North Shore CC	Helvers Rd	Glenfield	100	123.9	13.8	2.54	80	5.5	1.4	6.9	23.0	580	-	-	1968	1998	30
North Shore CC	Laser Pl	Glenfield	100	123.3	14.0	2.52	110	3.7	0.7	4.4	20.0	684	-	-	1977	1998	21
North Shore CC	Mayall Ave	Glenfield	100	121.7	13.9	2.50	110	3.6	2.5	6.1	22.0	463	-	-	1973	1998	25
North Shore CC	Merida Pl	Glenfield	100	124.1	13.7	2.57	110	3.5	2.7	6.2	22.0	199	-	-	1982	1998	16
North Shore CC	Oton St	Glenfield	100	125.6	14.6	2.54	110	4.3	2.5	6.8	24.0	599	-	-	1968	1998	30
North Shore CC	Randall Pl	Birkdale	100	123.3	13.9	2.80	135	3.1	2.5	5.6	16.0	259	-	-	1974	1998	24
North Shore CC	Standish Pl	Glenfield	100	123.0	14.1	4.17	110	4.1	1.2	5.3	23.0	601	-	-	1976	1998	22
North Shore CC	Tactius Pl	Glenfield	100	124.7	14.4	2.84	110	3.2	1.0	4.2	17.0	676	-	-	1982	1998	16
North Shore CC	Taurus Cres	Birkdale	100	124.4	13.9	2.53	110	3.4	2.9	6.3	17.0	494	-	-	1967	1998	31
North Shore CC	Tea Pl	Glenfield	100	122.2	13.7	2.51	110	5.7	0.0	5.7	23.0	473	-	-	1979	1998	19
North Shore CC	Theban Pl	Glenfield	100	122.8	13.6	2.57	110	4.6	0.0	4.6	22.0	537	-	-	1979	1998	19



Local Authority	Location Description	City/Town	Pipe DN (mm)	Mean Pipe OD (mm)	Min. Pipe Wall Thickness (mm)	Pipe Specific Gravity	Working Pressure (m)	Max. External Def'n (mm)	Max. Internal Def'n (mm)	Total Def'n (mm)	Water Absorp. (%)	Bench Burst Press. (m)	Average Ext. Barcol Hardness	Average Int. Barcol Hardness	Year of Installation	Year of Appraisal	Sample Age
North Shore CC	Unknown	Glenfield	100	123.4	13.4	2.72	80	3.8	3.9	7.7	21.0	509	-	-	1968	1998	30
North Shore CC	Ashfield Rd	Glenfield	150	179.0	17.7	3.33	80	2.1	2.3	4.4	16.0	463	-	-	1977	1998	21
North Shore CC	Ashley Ave	Torbay	150	179.2	18.9	3.94	118	3.6	2.3	5.9	20.0	617	-	-	1977	1998	21
North Shore CC	Athens Dr	Glenfield	150	179.6	16.7	4.17	110	2.9	2.3	5.2	11.0	586	-	-	1985	1998	13
North Shore CC	Athens Dr	Glenfield	150	180.7	18.9	3.96	110	2.8	2.3	5.1	17.0	626	-	-	1985	1998	13
North Shore CC	Bush Rd	Albany	150	181.6	17.4	3.98	85	3.7	2.6	6.3	20.0	485	-	-	1979	1998	19
North Shore CC	Pemberton Ave	Glenfield	150	179.2	15.9	3.68	110	3.6	2.1	5.7	19.0	437	-	-	1976	1998	22
North Shore CC	Santiago Cres	Glenfield	150	179.9	12.6	4.39	110	2.1	1.6	3.7	13.0	327	-	-	1984	1998	14
North Shore CC	Trails Rd	Glenfield	150	178.5	15.8	3.96	110	2.7	1.9	4.6	14.0	437	-	-	1979	1998	19
North Shore CC	Trails Rd	Glenfield	150	178.1	16.2	3.75	110	3.6	2.0	5.6	18.0	434	-	-	1979	1998	19
North Shore CC	6 Takrouna	Linton	100	124.0	11.6	1.65	41	4.0	3.0	7.0	16.7	-	65	48	1967	2000	33
NZ Army	7 Whites Rd	Burnham	100	126.7	16.6	-	28	1.5	4.0	5.5	-	-	-	-	1960	1999	39
NZ Army	Moia St line	Burnham	100	130.6	18.0	-	28	4.5	6.0	10.5	-	-	-	-	1960	1999	39
NZ Army	Puttick Road	Linton	100	125.5	17.4	1.68	29	3.5	4.5	8.0	10.4	-	5	20	1942	2000	58
NZ Army	12 Kippenberger	Linton	50	181.5	17.6	1.72	29	5.0	1.0	6.0	10.6	-	5	36	1955	2000	45
NZ Army	B27 Dimers Road	Linton	150	179.0	16.3	1.74	29	4.5	5.0	9.5	8.0	-	30	32	1973	2000	27
NZ Army	Fosters Road	Linton	150	179.0	16.5	1.69	29	5.0	4.5	9.5	13.7	-	0	51	1967	2000	33
NZ Army	X37 Delivery line to tower	Burnham	150	183.9	21.9	-	38	1.5	6.0	7.5	-	-	-	-	1960	1999	39
NZ Army	E17 Rowlings Road	Linton	200	235.0	20.0	1.71	29	4.5	5.0	9.5	11.8	-	1	48	1960	2000	40
Porirua CC	123 Champion St	Porirua	50	74.5	12.7	4.6	41	4.6	1.6	6.2	-	-	-	-	1956	1999	43
Porirua CC	34 Champion St	Porirua	50	73.2	11.4	-	56	1.9	1.9	3.8	-	-	-	-	1956	1999	43
Porirua CC	39 Levant Cres	Porirua	50	72.9	11.5	-	72	3.2	2.5	5.7	-	-	-	-	1965	1999	34
Porirua CC	8 Hazzard Gr	Porirua	50	75.8	12.7	-	92	4.2	2.9	7.1	-	-	-	-	1963	1999	36
Porirua CC	8 Leicester St	Porirua	50	71.7	11.3	-	82	2.4	1.4	3.8	-	-	-	-	1961	1999	38
Porirua CC	Chr. Hazzard Gr and Callopie St	Porirua	50	73.7	12.4	-	92	0.7	2.6	3.3	-	-	-	-	1963	1999	36
Porirua CC	Mungavin Avenue	Porirua	50	74.3	12.5	-	82	1.8	3.3	5.0	-	-	-	-	1959	1999	40
Porirua CC	17 York Pl	Porirua	100	126.5	17.1	-	61	3.1	2.6	5.7	-	-	-	-	1961	1999	36
Porirua CC	19-21 Cluny Rd	Porirua	100	124.1	12.2	-	77	1.4	2.1	3.5	-	-	-	-	1956	1999	43
Porirua CC	58 Cluny Rd	Porirua	100	123.7	12.4	-	66	4.8	4.3	9.1	-	-	-	-	1956	1999	43
Porirua CC	Gordon Rd	Porirua	100	122.0	12.2	-	82	0.3	3.5	3.8	-	-	30	30	1956	1999	43
Porirua CC	Mana Esplanade	Porirua	100	122.6	11.7	-	82	2.9	0.0	2.9	-	-	-	-	1966	1999	33
Porirua CC	Moana Rd	Hongoeka Bay	100	124.9	12.4	-	77	0.8	4.0	4.8	-	-	-	-	1956	1999	43
Porirua CC	Passive Grove	Porirua	100	122.8	12.3	-	82	3.0	2.4	5.4	-	-	5	35	1970	1999	29
Porirua CC	SH68 (Paremata Bridge)	Porirua	100	123.1	12.1	-	87	2.5	3.6	6.1	-	-	-	-	1956	1999	43
Porirua CC	South Beach Rd	Porirua	100	122.7	11.5	-	82	0.5	3.8	4.3	-	-	50	30	1956	1999	43
Porirua CC	Terrace Rd	Porirua	100	124.5	13.2	-	82	1.3	2.6	3.9	-	-	58	4	1959	1999	40
Porirua CC	Trevor Toe	Paremata	100	124.1	12.4	-	82	2.9	3.5	6.4	-	-	-	-	1956	1999	43
Porirua CC	Whimake	Porirua	100	124.4	13.7	-	92	1.8	3.5	5.3	-	-	-	-	1959	1999	40
Porirua CC	4 Bedford St	Porirua	150	180.0	12.6	-	82	2.4	4.3	6.7	-	-	-	-	1961	1999	38
Porirua CC	Windsley Ave	Porirua	150	182.5	21.2	-	82	2.8	3.4	6.2	-	-	-	-	1954	1999	45
Porirua CC	Tryon Street	Central	100	127.1	17.9	2.17	62	4.0	2.4	6.4	26	350	-	-	1930	1999	69
Porirua CC	Pukuaia St	Central	100	127.2	17.7	1.56	81	3.6	4.2	7.8	30	344	-	-	1955	1999	44
Porirua CC	11 Dawson Drive	Ngongotaha	100	125.6	17.5	1.32	83	4.3	4.0	8.3	41	198	-	-	1975	1999	24
Porirua CC	Chr Bedwardine & Beaumonts Rd	Ngongotaha	100	126.8	17.0	1.53	88	4.0	3.8	7.8	32	281	-	-	1954	1999	45
Porirua CC	11 Hamora Place	Eastern	100	123.3	13.1	1.76	75	3.4	2.8	6.2	21	438	-	-	1970	1999	29
Porirua CC	30 Rangitūi Street	Ngongotaha	100	124.2	17.1	1.69	86	3.1	5.3	8.4	23	178	-	-	1954	1999	45
Porirua CC	Chr Farnsworth & Robinson Ave	Eastern	100	122.2	12.4	1.54	104	5.5	6.1	11.6	29	424	-	-	1963	1999	36
Porirua CC	36 Rangitūi Street	Ngongotaha	100	124.3	17.2	1.55	86	3.1	5.5	8.6	28	162	-	-	1954	1999	45
Porirua CC	Pukeneri Road	Central	200	234.4	19.5	1.80	55	3.5	4.1	7.6	17	183	-	-	1975	2000	25
Porirua CC	6 Melrose Ave	Eastern	100	123.9	13.6	1.80	96	2.7	4.3	7.0	18	183	-	-	1963	2000	37



Local Authority	Location Description	City/Town	Pipe DN (mm)	Mean Pipe OD (mm)	Min. Pipe Wall Thickness (mm)	Pipe Specific Gravity	Working Pressure (m)	Max. External Def'n (mm)	Max. Internal Def'n (mm)	Total Def'n (mm)	Water Absorp. (%)	Bench Burst Press. (m)	Average Ext. Barcol Hardness	Average Int. Barcol Hardness	Year of Installation	Year of Appraisal	Sample Age
Selwyn DC	Springston Pipeline	Springston	100	125.0	14.0	-	24	3.5	4.0	7.5	-	-	-	-	1968	2000	32
Taupo DC	Puanga Street	Tokaanu	100	123.4	10.6	-	70	6.0	5.0	11.0	-	-	-	-	1960	2000	40
Taupo DC	Mangakino Avenue Rd	Mangakino	225	262.0	28.2	-	24	0.5	10.2	10.7	-	-	-	-	1947	2000	53
Timaru DC	Evens St	Timaru	50	70.3	9.9	1.83	52	2.0	4.0	6.0	18.2	632	-	-	1962	1999	37
Timaru DC	Miro St	Timaru	50	72.1	10.8	1.85	65	4.0	4.5	8.5	12.4	-	-	-	1965	1999	34
Timaru DC	North St	Timaru	50	73.7	11.6	1.96	53	2.5	4.5	7.0	8.9	835	-	-	1985	1999	14
Timaru DC	Sophia St (outside Timaru Mfrs)	Timaru	50	70.8	10.1	1.80	70	3.0	6.0	9.0	13.9	-	-	-	1950	1999	49
Timaru DC	Andrew St	Timaru	100	127.7	18.2	1.85	55	4.5	7.0	11.5	10.1	-	-	-	1962	1999	47
Timaru DC	Clyde Carr Cres. (23 Luxmoore Rd)	Timaru	100	124.0	13.1	1.92	70	4.5	5.0	9.5	10.3	778	-	-	1967	1999	32
Timaru DC	Flemington St	Timaru	100	124.0	14.0	2.05	67	3.5	4.0	7.5	5.8	-	-	-	1975	1999	24
Timaru DC	George St	Geraldine	100	119.1	14.1	1.38	50	7.0	5.5	12.5	31.4	527	-	-	1956	1999	43
Timaru DC	Goulds Rd (BLUE)	Timaru	100	127.8	13.8	1.89	60	4.5	4.5	9.0	9.0	-	-	-	1957	1999	42
Timaru DC	Guise St	Timaru	100	125.8	14.4	2.10	50	3.0	3.0	6.0	6.8	715	-	-	1989	1999	10
Timaru DC	June St (Historic 8/88)	Timaru	100	122.0	11.7	1.85	60	3.5	8.0	11.5	10.8	-	-	-	1960	1999	39
Timaru DC	Morgans Rd, New Life Centre	Timaru	100	124.1	13.1	1.97	54	3.0	4.5	7.5	9.3	-	-	-	1990	1999	19
Timaru DC	Princes St	Timaru	100	124.0	13.0	-	50	3.5	5.5	9.0	-	-	-	-	1966	1999	33
Timaru DC	Somerset St	Timaru	100	126.5	17.0	1.95	60	2.0	5.5	7.5	6.5	-	-	-	1955	1999	44
Timaru DC	Bridge Street	Geraldine	150	178.0	17.5	-	59	8.0	6.4	14.4	-	-	-	-	1956	1999	43
Timaru DC	Butler St	Timaru	150	180.0	12.1	1.94	65	3.0	3.0	6.0	6.3	-	-	-	1974	1999	25
Timaru DC	Dee St	Timaru	150	179.0	16.0	1.84	58	3.0	4.0	7.0	10.4	528	-	-	1979	1999	20
Timaru DC	Forest Rd	Geraldine	150	180.0	12.4	-	50	4.5	5.0	9.5	-	-	-	-	1972	1999	27
Timaru DC	Grey Rd	Timaru	150	179.2	15.1	1.91	50	1.5	2.5	4.0	6.3	-	-	-	1983	1999	16
Timaru DC	Hilton Highway	Timaru	150	178.0	15.7	-	75	6.0	6.0	12.0	15.0	-	-	-	1966	2000	34
Timaru DC	King St, Redruth	Timaru	150	178.8	14.3	1.77	50	4.0	4.5	8.5	-	-	-	-	1960	1999	39
Timaru DC	Lachlan St	Timaru	150	178.0	15.6	-	50	4.0	4.5	8.5	-	-	-	-	1966	1999	33
Timaru DC	Finders St	Timaru	200	236.9	20.2	2.05	67	3.0	3.5	6.5	5.4	586	-	-	1960	1999	19
Timaru DC	Halstead Rd	Pleasant Pt	200	233.5	19.0	1.88	50	3.5	6.0	9.5	8.9	-	-	-	1964	1999	35
Timaru DC	Hilton Highway, Meadows Rd	Timaru	200	234.0	18.2	-	80	4.5	7.0	11.5	-	-	-	-	1966	1999	33
Timaru DC	Hilton Highway, Outside NZ Safety Ltd	Timaru	200	234.0	18.8	1.88	80	3.5	5.5	9.0	10.7	-	-	-	1966	1999	33
Timaru DC	Meadows Rd, Washdyke Ck, Br	Timaru	200	237.3	19.9	1.98	80	3.5	4.0	7.5	7.8	-	-	-	1966	1999	33
Timaru DC	Richard Pearce Dr	Timaru	200	235.5	19.4	-	59	6.0	6.5	12.5	-	-	-	-	1969	1999	30
Timaru DC	Old North Rd & Andrew St	Timaru	250	287.8	23.1	1.95	45	5.0	4.5	9.5	7.5	-	-	-	1965	1999	34
Timaru DC	Oari Pipeline (near Res.)	Geraldine	250	292.7	23.9	-	10	4.5	5.0	9.5	-	-	-	-	1975	1999	24
Timaru DC	Ohipua Rd	Timaru	250	288.0	22.0	2.00	45	4.5	5.0	9.5	5.8	-	-	-	1966	1999	33
Timaru DC	Hilton Highway, Washdyke	Timaru	300	349.7	25.4	2.13	80	1.0	4.0	5.0	3.2	-	-	-	1973	1999	26
Timaru DC	Ohipua Rd	Timaru	300	349.3	26.8	2.00	45	4.5	5.0	9.5	-	-	-	-	1965	1999	34
Upper Hutt CC	1 Birch Grove	Upper Hutt	100	123.0	13.0	-	70	1.2	6.7	7.9	-	-	-	-	1954	1992	38
Upper Hutt CC	1 Whitehall Grove	Upper Hutt	100	124.5	13.5	-	81	2.0	3.0	5.0	-	-	-	-	1967	1992	25
Upper Hutt CC	10 Whitehall Grove	Upper Hutt	100	125.7	14.0	-	81	3.0	2.0	5.0	-	-	-	-	1967	1992	25
Upper Hutt CC	2 Birch Grove	Upper Hutt	100	121.0	13.0	-	70	7.0	1.5	8.5	-	-	-	-	1954	1993	39
Upper Hutt CC	21 Pinehill Crescent	Upper Hutt	100	125.7	17.0	-	81	2.5	3.5	6.0	-	-	-	-	1962	1992	30
Upper Hutt CC	Barton Road	Upper Hutt	100	127.7	16.0	-	70	1.0	8.0	9.0	-	-	-	-	1954	1992	38
Upper Hutt CC	Birch Grove	Upper Hutt	100	121.9	13.0	-	70	5.5	1.2	6.7	-	-	-	-	1954	1992	38
Upper Hutt CC	Golders Road	Upper Hutt	100	130.0	16.0	-	70	3.5	8.5	12.0	-	-	-	-	1950	1993	43
Upper Hutt CC	Joeelyn Cres	Upper Hutt	100	123.0	13.0	-	60	4.5	4.2	8.7	-	-	-	-	1963	1992	39
Upper Hutt CC	McMurtrie Grove	Upper Hutt	100	127.8	18.2	-	81	3.0	3.5	6.5	-	-	-	-	1962	1992	30
Upper Hutt CC	Winchester Avenue	Upper Hutt	100	124.0	13.0	-	70	2.6	2.8	5.4	-	-	-	-	1954	1992	38
Upper Hutt CC	105 Pinehaven Road	Upper Hutt	150	179.0	16.0	-	70	7.0	3.5	10.5	-	-	-	-	1955	1992	39
Upper Hutt CC	11 Maymorn Road	Upper Hutt	150	179.0	12.0	-	30	0.2	2.6	2.8	-	-	-	-	1973	1994	21



Local Authority	Location Description	City/Town	Pipe DN (mm)	Mean Pipe OD (mm)	Min. Pipe Wall Thickness (mm)	Pipe Specific Gravity	Working Pressure (m)	Max. External Def'n (mm)	Max. Internal Def'n (mm)	Total Def'n (mm)	Water Absorp. (%)	Bench Burst Press. (m)	Average Ext. Barcol Hardness	Average Int. Barcol Hardness	Year of Installation	Year of Appraisal	Sample Age
Upper Hutt CC	36 Maymorn Road	Upper Hutt	150	179.8	16.3	-	100	4.2	3.3	7.5	-	-	-	-	1973	2000	27
Upper Hutt CC	78 Pinehaven Road	Upper Hutt	150	178.2	16.0	-	70	7.0	3.0	10.0	-	-	-	-	1953	1992	39
Upper Hutt CC	82 Pinehaven Road	Upper Hutt	150	178.3	16.0	-	70	2.5	2.5	5.0	-	-	-	-	1953	1992	39
Upper Hutt CC	82/84 Pinehaven Road	Upper Hutt	150	178.3	16.0	-	70	2.5	2.5	5.0	-	-	-	-	1953	1992	39
Upper Hutt CC	Atzac Road	Upper Hutt	150	185.0	20.0	-	70	1.5	8.5	10.0	-	-	-	-	1942	1991	49
Upper Hutt CC	Beth Street	Upper Hutt	150	185.0	16.0	-	65	1.5	8.0	9.5	-	-	-	-	1947	1991	44
Upper Hutt CC	Elmslie Road	Upper Hutt	150	182.0	16.0	-	70	6.2	3.5	9.7	-	-	-	-	1953	1993	40
Upper Hutt CC	Maymorn Road - Pig Farm	Upper Hutt	150	179.6	16.8	-	90	8.0	3.5	11.5	-	-	-	-	1973	2000	27
Upper Hutt CC	Wynham Road	Upper Hutt	150	178.0	16.0	-	70	7.5	2.8	10.3	-	-	-	-	1953	1994	41
Waikato DC	Bailey St	Huntly	100	130.0	18.2	-	56	0.5	3.0	3.5	-	-	-	-	1943	1999	56
Waikato DC	Craft Tce	Huntly	100	122.9	13.5	-	56	5.5	2.5	8.0	-	-	-	-	1980	1999	19
Waikato DC	Ellery St	Ngaruawahia	100	122.5	13.3	-	51	6.5	5.0	11.5	-	-	-	-	1973	1999	26
Waikato DC	George St	Ngaruawahia	100	124.0	14.0	-	51	3.5	3.5	7.0	-	-	-	-	1973	1999	26
Waikato DC	Great South Rd	Ngaruawahia	100	127.3	18.6	-	51	7.0	5.5	12.5	-	-	-	-	1953	1999	46
Waikato DC	Great South Rd	Huntly	100	132.5	21.2	-	56	1.0	1.0	2.0	-	-	-	-	1938	1999	61
Waikato DC	Herewini St	Meremere	100	125.5	17.5	-	51	7.5	4.0	11.5	-	-	-	-	1960	1999	39
Waikato DC	Kirihihi Rd	Huntly	100	125.5	14.0	-	36	6.5	5.0	11.5	-	-	-	-	1964	1999	35
Waikato DC	Kone Kone St	Meremere	100	123.5	16.8	-	51	3.0	4.0	7.0	-	-	-	-	1960	1999	39
Waikato DC	Naho/Meremere Sls	Meremere	100	123.5	13.4	-	51	5.0	5.0	10.0	-	-	-	-	1960	1999	39
Waikato DC	Old Taupiri Rd	Ngaruawahia	100	124.7	14.2	-	51	6.0	6.0	12.0	-	-	-	-	1963	1999	36
Waikato DC	Paki St	Huntly	100	121.5	12.8	-	56	4.5	5.0	9.5	-	-	-	-	1964	1999	35
Waikato DC	Queen St	Ngaruawahia	100	124.2	14.1	-	51	6.0	5.0	11.0	-	-	-	-	1973	1999	26
Waikato DC	River View Rd	Huntly	100	127.3	19.1	-	51	2.5	6.0	8.5	-	-	-	-	1966	1999	33
Waikato DC	Russell Rd	Huntly	100	124.1	16.9	-	36	3.0	6.0	9.0	-	-	-	-	1966	1999	33
Waikato DC	Simmis St	Ngaruawahia	100	123.5	13.4	-	51	5.0	4.5	9.5	-	-	-	-	1965	1999	34
Waikato DC	Tanwharau St	Huntly	100	122.8	13.7	-	56	3.0	5.0	8.0	-	-	-	-	1957	1999	42
Waikato DC	Te Paea Ave (North)	Meremere	100	124.0	13.6	-	51	7.0	4.5	11.5	-	-	-	-	1960	1999	39
Waikato DC	Te Paea Ave (South)	Meremere	100	124.5	17.0	-	51	7.0	7.5	14.5	-	-	-	-	1960	1999	39
Waikato DC	Thomas St	Ngaruawahia	100	124.5	17.1	-	51	3.5	6.0	9.5	-	-	-	-	1953	1999	46
Waikato DC	Tilher St	Huntly	100	128.1	18.1	-	56	3.0	7.5	10.5	-	-	-	-	1944	1999	55
Waikato DC	Waikato Esplanade	Ngaruawahia	100	122.3	13.3	-	51	4.0	5.5	9.5	-	-	-	-	1973	1999	26
Waikato DC	Waingaro Rd	Ngaruawahia	100	124.7	17.3	-	51	3.0	6.0	9.0	-	-	-	-	1953	1999	46
Waikato DC	Walpa Esplanade	Ngaruawahia	100	122.5	13.7	-	51	5.0	4.0	9.0	-	-	-	-	1963	1999	36
Waimate DC	Dash Street	Waimate	100	126.0	16.6	-	73	6.0	3.0	9.0	-	-	-	-	1960	1999	39
Waimate DC	Godsmith Street	Waimate	100	123.5	13.0	-	73	5.2	2.0	7.2	-	-	-	-	1968	1999	31
Waipa DC	Bond Rd	Te Awamutu	100	124.5	11.6	-	53	6.0	5.5	11.5	-	-	-	-	1950	2000	50
Waipa DC	Hessellere St	Te Awamutu	100	123.5	17.0	-	53	4.0	5.0	9.0	-	-	-	-	1950	2000	50
Waipa DC	Paik Rd	Te Awamutu	100	121.5	13.6	-	53	2.0	1.5	3.5	-	-	-	-	1993	2000	7
Waipa DC	Thorncombe Rd	Te Awamutu	100	125.0	18.0	-	32	4.0	7.0	11.0	-	-	-	-	1960	2000	40
Waipa DC	Wardsworth St	Cambridge	100	122.5	13.0	-	-	4.0	4.0	8.0	-	-	-	-	2000	2000	2000
Waipa DC	Bridgman St	Te Awamutu	150	179.0	21.6	-	53	5.5	4.0	9.5	-	-	-	-	1955	2000	45
Waipa DC	Hamilton Rd	Cambridge	200	233.0	23.8	-	-	5.5	4.0	9.5	-	-	-	-	2000	2000	2000
Waikare CC	10 Hevet St	Waikare	50	73.4	11.6	1.46	68	5.0	0.0	5.0	25	836	-	-	1968	1998	30
Waikare CC	111 Ferry Pde	Waikare	50	71.9	11.3	1.55	36	4.0	3.0	7.0	24	-	-	-	1985	1998	13
Waikare CC	36 Durham Rd	Waikare	50	74.3	11.9	1.66	48	6.0	2.5	8.5	19	504	-	-	1959	1998	39
Waikare CC	40 Rimutaka St	Waikare	50	69.8	9.3	1.21	95	3.0	0.0	3.0	44	-	-	-	1963	1998	35
Waikare CC	426 Don Buck Rd	Waikare	50	73.0	11.8	1.51	50	4.0	3.5	7.5	23	-	-	-	1965	1998	33
Waikare CC	5 Braims Rd	Waikare	50	72.0	10.8	1.48	51	6.0	0.0	6.0	31	490	-	-	1961	1998	37
Waikare CC	51 Cronin Ave	Waikare	50	73.1	11.6	1.79	58	4.0	0.0	4.0	16	400	-	-	1957	1998	41
Waikare CC	65 Fairquhar St	Waikare	50	72.6	12.2	1.70	53	3.0	2.0	6.0	17	517	-	-	1958	1998	40



Local Authority	Location Description	City/Town	Pipe DN (mm)	Mean Pipe OD (mm)	Min. Pipe Wall Thickness (mm)	Pipe Specific Gravity	Working Pressure (m)	Max. External Def'n (mm)	Max. Internal Def'n (mm)	Total Def'n (mm)	Water Absorp. (%)	Bench Burst Press. (m)	Average Ext. Barcol Hardness	Average Int. Barcol Hardness	Year of installation	Year of Appraisal	Sample Age
Waitakere CC	9 Granger Rd	Waitakere	50	70.0	9.8	1.35	43	6.0	0.0	6.0	34	327	-	-	1956	1998	42
Waitakere CC	95 Rathgar Rd	Waitakere	50	74.1	12.3	1.82	57	3.0	0.0	3.0	12	706	-	-	1962	1998	36
Waitakere CC	123 Darroff St	Waitakere	100	125.0	14.3	1.76	55	4.0	0.0	4.0	14	456	-	-	1964	1998	34
Waitakere CC	15 Neal Ave	Waitakere	100	122.9	16.4	1.39	46	6.0	2.0	8.0	31	-	-	-	1956	1998	42
Waitakere CC	16 Valley Rd	Waitakere	100	124.0	13.7	1.91	112	2.0	0.0	4.0	12	351	-	-	1959	1998	9
Waitakere CC	2 Covi Ave	Waitakere	100	128.5	17.8	1.91	49	4.0	0.0	4.0	6	628	-	-	1950	1998	48
Waitakere CC	226 Sadley Rd	Waitakere	100	125.4	14.0	1.76	27	5.0	0.0	5.0	17	422	-	-	1959	1998	39
Waitakere CC	23 Kokiri St	Waitakere	100	123.5	13.6	1.76	51	4.0	0.0	4.0	14	-	-	-	1953	1998	45
Waitakere CC	24 Terra Nova Pl	Waitakere	100	123.7	13.2	1.83	41	4.0	0.0	4.0	13	410	-	-	1974	1998	24
Waitakere CC	28 Eastglen Rd	Waitakere	100	125.1	14.7	1.70	55	6.0	0.0	6.0	15	548	-	-	1966	1998	32
Waitakere CC	3 Nicholas Ave	Waitakere	100	124.2	13.6	1.79	95	5.0	0.0	5.0	13	508	-	-	1967	1998	31
Waitakere CC	51 Onedin St	Waitakere	100	121.8	13.5	1.82	84	5.0	2.5	7.5	16	249	-	-	1984	1998	14
Waitakere CC	55 Donovin Dr	Waitakere	100	121.7	13.5	1.78	80	4.0	0.0	4.0	15	452	-	-	1976	1998	22
Waitakere CC	59 Chilcott Ave	Waitakere	100	122.7	13.3	1.72	69	6.0	0.0	6.0	15	532	-	-	1969	1998	29
Waitakere CC	65 Tanekaha Rd	Waitakere	100	126.9	12.7	1.70	75	5.0	5.0	10.0	16	-	-	-	1989	1998	9
Waitakere CC	Frank Evans Pl	Waitakere	100	123.8	13.9	1.74	56	4.0	0.0	4.0	12	457	-	-	1982	1998	16
Waitakere CC	13 Lagoon Way	Waitakere	150	179.0	16.4	1.75	79	4.0	0.0	4.0	14	509	-	-	1986	1998	12
Waitakere CC	14 Watwick St	Waitakere	150	127.9	19.4	1.64	40	3.0	4.0	7.0	19	251	-	-	1971	1998	27
Waitakere CC	33 Luanda Dr	Waitakere	150	179.0	16.7	1.82	54	5.0	0.0	5.0	13	330	-	-	1975	1998	23

Deterioration Model Calculations

Local Authority	Location Description	City/Town	Input from National Data Base										Calculations Based on Sample Data						Deth Chart Input						Deth Model Output		
			Pipe DN (mm)	Pipe OD (mm)	Min. Pipe WT (measured) (mm)	Max. External Deth (mm)	Max. Internal Deth (mm)	Year of Installation	Year of Appraisal	Sample Age (years)	Total Deth (mm)	Without Result from Deth Model?	Results to Include in Model (90%)	Sample Age (years)	Total Deth (mm)	Results to Include in Model (85%)	Sample Age (years)	Total Deth (mm)	Results to Include in Model (100%)	Sample Age (years)	Total Deth (mm)	Sample Deth Rate (mm/year)	Modelled Deth (mm)	Comparison with National Average			
Ashburton DC	John St	Ashburton	100	123.2	18.3	2.0	5.0	1959	1959	30	7.0	No	Yes	30.0	7.0	Yes	30.0	7.0	Yes	30.0	7.0	0.233	6.8	3%			
Ashburton DC	Thompson St	Ashburton	100	123.0	11.5	3.0	4.0	1959	1959	30	7.0	No	Yes	30.0	7.0	Yes	30.0	7.0	Yes	30.0	7.0	0.233	6.8	3%			
Ashburton DC	Trevors Rd	Ashburton	100	123.0	11.2	3.0	3.0	1959	1959	30	6.0	No	Yes	30.0	6.0	Yes	30.0	6.0	Yes	30.0	6.0	0.200	6.8	-12%			
Ashburton DC	Bryant St	Ashburton	150	178.5	12.2	5.0	4.0	1965	1965	34	9.0	No	Yes	34.0	9.0	Yes	34.0	9.0	Yes	34.0	9.0	0.265	7.7	17%			
Ashburton DC	Farm Rd	Ashburton	150	179.9	12.3	3.0	5.0	1969	1969	30	8.0	No	Yes	30.0	8.0	Yes	30.0	8.0	Yes	30.0	8.0	0.267	6.8	18%			
Ashburton DC	McNally St	Ashburton	200	237.7	15.9	4.5	2.5	1967	1967	24	7.0	No	No	FALSE	FALSE	Yes	24.0	7.0	Yes	24.0	7.0	0.282	5.4	29%			
Ashburton DC	Carterton	Carterton	100	124.4	16.9	5.0	9.0	1960	1960	37	14.0	No	No	FALSE	FALSE	Yes	37.0	14.0	Yes	37.0	14.0	0.378	8.4	67%			
Christchurch CC	Av Street	Christchurch	100	127.0	17.7	2.0	1.0	1961	1961	38	3.0	No	No	FALSE	FALSE	Yes	38.0	3.0	Yes	38.0	3.0	0.079	8.6	-65%			
Christchurch CC	Brylton Street	Christchurch	100	124.1	11.0	3.0	3.5	1960	1960	39	6.5	No	No	FALSE	FALSE	Yes	39.0	6.5	Yes	39.0	6.5	0.167	8.8	-27%			
Christchurch CC	Euston Street	Christchurch	100	126.2	17.5	3.0	5.5	1950	1959	49	8.5	No	Yes	49.0	8.5	Yes	49.0	8.5	Yes	49.0	8.5	0.173	11.1	-10%			
Christchurch CC	Hansons Lane	Christchurch	100	127.0	18.2	1.0	7.0	1960	1960	39	8.0	No	Yes	39.0	8.0	Yes	39.0	8.0	Yes	39.0	8.0	0.205	6.8	-10%			
Christchurch CC	Hood Street	Christchurch	100	127.5	17.7	4.0	3.0	1945	1945	54	7.0	No	No	FALSE	FALSE	Yes	54.0	7.0	Yes	54.0	7.0	0.130	12.3	-43%			
Christchurch CC	Hooker Avenue	Christchurch	100	126.8	17.0	2.0	4.5	1960	1960	39	6.5	No	No	FALSE	FALSE	Yes	39.0	6.5	Yes	39.0	6.5	0.167	6.8	-21%			
Christchurch CC	Knockwite Street	Christchurch	100	127.0	18.0	7.0	1.0	1949	1949	51	8.0	No	No	FALSE	FALSE	Yes	51.0	8.0	Yes	51.0	8.0	0.157	11.6	-31%			
Christchurch CC	Knowles Street	Christchurch	100	130.3	18.1	7.5	4.5	1925	1959	74	12.0	Yes	No	FALSE	FALSE	Yes	74.0	12.0	Yes	74.0	12.0	0.163	16.9	-29%			
Christchurch CC	Main Street West	Christchurch	100	127.0	17.7	3.0	4.0	1950	2000	50	7.0	No	No	FALSE	FALSE	Yes	50.0	7.0	Yes	50.0	7.0	0.140	11.3	-38%			
Christchurch CC	On Nelson Street	Christchurch	100	127.0	18.0	2.0	6.0	1950	2000	50	6.0	No	Yes	50.0	6.0	Yes	50.0	6.0	Yes	50.0	6.0	0.120	11.3	-35%			
Christchurch CC	Ocean View Terrace	Christchurch	100	119.0	14.7	3.5	2.5	1953	1959	45	5.0	No	No	FALSE	FALSE	Yes	45.0	5.0	Yes	45.0	5.0	0.130	10.4	-13%			
Christchurch CC	Payroll Ave	Christchurch	100	125.0	15.1	5.0	4.5	1960	1959	39	9.5	No	Yes	39.0	9.5	Yes	39.0	9.5	Yes	39.0	9.5	0.244	5.6	7%			
Christchurch CC	Strawson Road	Christchurch	100	123.8	13.0	3.5	5.0	1965	1959	34	8.5	No	Yes	34.0	8.5	Yes	34.0	8.5	Yes	34.0	8.5	0.250	7.7	10%			
Christchurch CC	Tul Street	Christchurch	100	125.0	13.4	5.0	4.0	1955	1959	44	9.0	No	No	FALSE	FALSE	Yes	44.0	9.0	Yes	44.0	9.0	0.205	10.0	-10%			
Christchurch CC	Tyrone Street	Christchurch	100	123.0	11.1	3.0	4.0	1965	1959	34	7.0	No	Yes	34.0	7.0	Yes	34.0	7.0	Yes	34.0	7.0	0.206	7.7	-9%			
Christchurch CC	Wall Street	Christchurch	100	124.5	11.8	0.5	4.0	1960	2000	40	4.5	No	No	FALSE	FALSE	Yes	40.0	4.5	Yes	40.0	4.5	0.113	9.1	-50%			
Christchurch CC	Clyde Road	Christchurch	150	181.0	12.5	1.5	3.0	1975	1999	24	4.5	No	Yes	24.0	4.5	Yes	24.0	4.5	Yes	24.0	4.5	0.188	5.4	-17%			
Christchurch CC	Gilberthorpes Road	Christchurch	150	178.3	11.6	2.0	5.5	1948	1989	51	7.5	No	Yes	51.0	7.5	Yes	51.0	7.5	Yes	51.0	7.5	0.147	11.6	-35%			
Christchurch CC	Hardwicke Street	Christchurch	150	180.3	15.4	2.5	3.5	1980	1989	19	6.0	No	No	FALSE	FALSE	Yes	19.0	6.0	Yes	19.0	6.0	0.316	4.3	39%			
Christchurch CC	Low Street	Christchurch	150	180.8	17.7	3.0	3.0	1960	2000	40	6.0	No	No	FALSE	FALSE	Yes	40.0	6.0	Yes	40.0	6.0	0.150	9.1	-34%			
Christchurch CC	Lydia Street	Christchurch	150	180.4	16.5	5.0	3.5	1982	1989	17	8.5	No	No	FALSE	FALSE	Yes	17.0	8.5	Yes	17.0	8.5	0.500	3.9	120%			
Christchurch CC	Malpa Street	Christchurch	150	181.5	20.8	6.5	3.0	1950	1989	49	9.5	No	Yes	49.0	9.5	Yes	49.0	9.5	Yes	49.0	9.5	0.194	11.1	-15%			
Christchurch CC	Waiman Road	Christchurch	150	180.5	16.2	6.0	5.0	1960	1960	39	11.0	No	No	FALSE	FALSE	Yes	39.0	11.0	Yes	39.0	11.0	0.282	8.8	24%			
Christchurch CC	Waima Road	Christchurch	150	181.1	16.7	6.0	3.0	1977	1989	22	9.0	No	No	FALSE	FALSE	Yes	22.0	9.0	Yes	22.0	9.0	0.409	5.0	80%			
Christchurch CC	Belfast Road	Christchurch	200	234.0	15.6	6.0	3.5	1966	2000	34	9.5	No	Yes	34.0	9.5	Yes	34.0	9.5	Yes	34.0	9.5	0.279	7.7	23%			
Christchurch CC	Byron Street	Christchurch	200	236.0	19.9	1.5	6.0	1972	2000	28	7.5	No	Yes	28.0	7.5	Yes	28.0	7.5	Yes	28.0	7.5	0.268	6.4	18%			
Christchurch CC	Canford Street	Christchurch	200	233.9	18.7	5.0	4.0	1966	1989	33	9.0	No	Yes	33.0	9.0	Yes	33.0	9.0	Yes	33.0	9.0	0.273	7.5	20%			
Christchurch CC	Fendall Road	Christchurch	200	237.0	16.5	4.0	4.0	1979	2000	21	8.0	No	No	FALSE	FALSE	Yes	21.0	8.0	Yes	21.0	8.0	0.181	4.8	68%			
Christchurch CC	Houses Avenue	Christchurch	200	231.5	19.7	0.5	4.0	1977	1989	22	4.5	No	Yes	22.0	4.5	Yes	22.0	4.5	Yes	22.0	4.5	0.205	5.0	-10%			
Christchurch CC	Main South Road, Templeton Station	Christchurch	200	230.7	15.1	3.0	4.0	1966	2000	34	7.8	No	Yes	34.0	7.8	Yes	34.0	7.8	Yes	34.0	7.8	0.239	7.7	-10%			
Christchurch CC	Queenspark Drive	Christchurch	200	230.0	20.1	3.0	4.0	1975	1989	24	7.0	No	Yes	24.0	7.0	Yes	24.0	7.0	Yes	24.0	7.0	0.269	5.9	18%			
Christchurch CC	Spring Road	Christchurch	200	230.0	20.1	3.0	4.0	1975	1989	24	7.0	No	Yes	24.0	7.0	Yes	24.0	7.0	Yes	24.0	7.0	0.269	5.9	18%			
Christchurch CC	Station Road	Christchurch	200	234.0	19.4	3.0	3.5	1955	1959	41	5.5	No	No	FALSE	FALSE	Yes	41.0	5.5	Yes	41.0	5.5	0.144	10.2	-25%			
Christchurch CC	Erinmont Street	Christchurch	225	265.0	29.9	4.0	4.0	1977	1959	52	7.0	No	No	FALSE	FALSE	Yes	52.0	7.0	Yes	52.0	7.0	0.135	11.8	-11%			
Christchurch CC	Ainsley Terrace	Christchurch	300	346.0	27.2	3.5	5.0	1947	1959	22	8.5	No	No	FALSE	FALSE	Yes	22.0	8.5	Yes	22.0	8.5	0.386	5.0	70%			
Christchurch CC	Darrock Street	Christchurch	300	339.5	18.6	3.5	5.0	1965	1959	34	8.5	No	Yes	34.0	8.5	Yes	34.0	8.5	Yes	34.0	8.5	0.250	7.7	10%			
Christchurch CC	Hills Road	Christchurch	300	344.0	25.1	2.5	3.0	1960	1989	39	5.5	No	No	FALSE	FALSE	Yes	39.0	5.5	Yes	39.0	5.5	0.141	8.8	-38%			
Christchurch CC	St Asaph Street	Christchurch	300	347.0	27.2	2.5	5.0	1970	1989	29	7.5	No	Yes	29.0	7.5	Yes	29.0	7.5	Yes	29.0	7.5	0.259	6.6	14%			
Christchurch CC	Waipeti Street	Christchurch	300	347.0	19.0	2.0	5.0	1965	2000	35	7.0	No	Yes	35.0	7.0	Yes	35.0	7.0	Yes	35.0	7.0	0.200	7.9	-12%			
Christchurch CC	Watts Road	Christchurch	300	339.0	18.2	2.0	6.0	1960	1989	39	8.0	No	Yes	39.0	8.0	Yes	39.0	8.0	Yes	39.0	8.0	0.205	8.6	-10%			
Far North DC	140 Commerce St	Kaitiaki	100	124.3	15.9	7.7	2.3	1960	1988	38	10.0	No	Yes	38.0	10.0	Yes	38.0	10.0	Yes	38.0	10.0	0.263	8.8	16%			
Far North DC	194 Commerce St	Kaitiaki	100	122.4	17.1	9.7	4.2	1960	1988	38	15.8	No	No	FALSE	FALSE	Yes	38.0	15.8	Yes	38.0	15.8	0.366	6.6	61%			
Far North DC	Farmford St	Kaitiaki	100	127.9	17.6	9.8	6.0	1960	1988	38	15.8	No	No	FALSE	FALSE	Yes	38.0	15.8	Yes	38.0	15.8	0.416	6.6	83%			
Far North DC	Puckey Ave (Int. Taiefe St)	Kaitiaki	100	126.0	17.3	9.4	3.7	1960	1988	38	13.1	No	No	FALSE	FALSE	Yes	38.0	13.1	Yes	38.0	13.1	0.345	6.6	52%			
Far North DC	195 Commerce St	Kaitiaki	150	179.7	15.9	3.5	1.8	1960	1988	38	5.3	No	No	FALSE	FALSE	Yes	38.0	5.3	Yes	38.0	5.3	0.139	8.6	-39%			
Far North DC	44 Commerce St																										

Deterioration Model Calculations

Local Authority	Location Description	Input from National Date Base					Calculations Based on Sample Data					Det'n Chart Input					Det'n Model Output			
		City/Town	Pipe DN (mm)	Pipe OD (mm)	Min. Pipe WT (measured) (mm)	Max. External Det'n (mm)	Max. Internal Det'n (mm)	Year of Installation	Year of Appraisal	Sample Age (years)	Total Det'n (mm)	Without Result from Det'n Model?	Results to Include in Model (90%)	Sample Age (years)	Total Det'n (mm)	Results to Include in Model (100%)	Sample Age (years)	Total Det'n (mm)	Sample Det'n Rate (mm/year)	Modelled Det'n (mm)
North Shore CC	Waitemata Rd	50	75.0	4.3	2.6	0.5	1967	1988	31	6.9	No	Yes	31.0	6.9	Yes	31.0	6.9	0.223	7.0	-2%
North Shore CC	Wekere Ave	50	75.0	3.8	0.5	0.5	1969	1988	29	4.3	No	Yes	29.0	4.3	Yes	29.0	4.3	0.148	6.6	-35%
North Shore CC	Wekere Ave	50	75.0	4.0	0.5	0.5	1969	1988	29	4.5	No	Yes	29.0	4.5	Yes	29.0	4.5	0.155	6.6	-32%
North Shore CC	Wekere Ave	50	75.0	4.8	0.6	0.6	1969	1988	29	5.4	No	Yes	29.0	5.4	Yes	29.0	5.4	0.186	6.6	-18%
North Shore CC	Facility Pl	100	124.4	3.8	0.5	0.5	1981	1988	17	4.0	No	Yes	17.0	4.0	Yes	17.0	4.0	0.235	3.9	4%
North Shore CC	Garmer St	100	124.0	4.2	2.2	2.2	1974	1988	24	6.4	No	Yes	24.0	6.4	Yes	24.0	6.4	0.267	5.4	18%
North Shore CC	Hellers Rd	100	123.3	3.8	5.5	1.4	1968	1988	30	6.9	No	Yes	30.0	6.9	Yes	30.0	6.9	0.230	6.8	1%
North Shore CC	Lease Pl	100	123.3	3.7	0.7	0.7	1977	1988	21	4.4	No	Yes	21.0	4.4	Yes	21.0	4.4	0.204	4.8	-8%
North Shore CC	Mayall Ave	100	121.7	3.9	3.6	2.5	1973	1988	25	6.1	No	Yes	25.0	6.1	Yes	25.0	6.1	0.244	5.7	8%
North Shore CC	Merida Pl	100	124.1	3.7	3.5	2.7	1982	1988	16	6.2	No	Yes	16.0	6.2	Yes	16.0	6.2	0.388	3.6	71%
North Shore CC	Oton St	100	123.6	4.6	4.3	2.5	1968	1988	30	6.8	No	Yes	30.0	6.8	Yes	30.0	6.8	0.227	5.6	0%
North Shore CC	Orton St	100	123.3	3.9	3.1	2.5	1974	1988	24	5.6	No	Yes	24.0	5.6	Yes	24.0	5.6	0.233	5.4	3%
North Shore CC	Standish Pl	100	123.0	4.1	4.1	1.2	1976	1988	22	5.3	No	Yes	22.0	5.3	Yes	22.0	5.3	0.241	5.0	6%
North Shore CC	Standish Pl	100	124.7	4.4	3.7	2.0	1985	1988	16	4.2	No	Yes	16.0	4.2	Yes	16.0	4.2	0.263	3.6	16%
North Shore CC	Teaupo Cres	100	124.4	3.3	2.9	2.0	1967	1988	31	6.5	No	Yes	31.0	6.5	Yes	31.0	6.5	0.203	7.0	-10%
North Shore CC	Teaupo Cres	100	122.2	3.7	3.7	0.0	1979	1988	19	3.7	No	No	19.0	3.7	Yes	19.0	3.7	0.300	4.3	32%
North Shore CC	Thapan Pl	100	122.6	3.6	4.6	0.0	1979	1988	19	4.6	No	Yes	19.0	4.6	Yes	19.0	4.6	0.242	4.3	7%
North Shore CC	Unknown	100	123.4	3.8	3.8	3.8	1968	1988	30	7.7	No	Yes	30.0	7.7	Yes	30.0	7.7	0.257	5.8	3%
North Shore CC	Asfield Rd	150	179.0	17.7	2.1	2.3	1977	1988	21	4.4	No	Yes	21.0	4.4	Yes	21.0	4.4	0.210	4.8	-5%
North Shore CC	Ashtly Ave	150	179.2	18.9	3.6	2.3	1977	1988	21	5.9	No	Yes	21.0	5.9	Yes	21.0	5.9	0.281	4.8	24%
North Shore CC	Alhena Dr	150	178.6	16.7	2.9	2.3	1985	1988	13	5.1	No	No	13.0	5.1	Yes	13.0	5.1	0.382	2.9	76%
North Shore CC	Alhena Dr	150	180.7	19.9	2.8	2.3	1985	1988	13	5.1	No	No	13.0	5.1	Yes	13.0	5.1	0.382	2.9	73%
North Shore CC	Bush Rd	150	181.6	17.4	3.7	2.6	1979	1988	19	6.3	No	Yes	19.0	6.3	Yes	19.0	6.3	0.332	4.3	46%
North Shore CC	Bush Rd	150	179.2	15.9	3.8	2.1	1976	1988	22	5.9	No	Yes	22.0	5.9	Yes	22.0	5.9	0.268	5.0	18%
North Shore CC	Pemberton Ave	150	178.9	12.6	2.1	1.6	1984	1988	14	3.7	No	Yes	14.0	3.7	Yes	14.0	3.7	0.264	3.2	16%
North Shore CC	Santiago Cres	150	178.5	15.8	2.7	1.9	1979	1988	19	4.6	No	Yes	19.0	4.6	Yes	19.0	4.6	0.242	4.3	7%
North Shore CC	Trals Rd	150	178.1	16.2	3.6	2.0	1979	1988	19	5.8	No	Yes	19.0	5.8	Yes	19.0	5.8	0.295	4.3	30%
North Shore CC	Trals Rd	150	178.1	16.2	3.6	2.0	1979	1988	19	5.8	No	Yes	19.0	5.8	Yes	19.0	5.8	0.295	4.3	30%
NZ Army	6 Takarua	100	124.0	11.6	4.0	3.0	1960	2000	39	7.0	No	Yes	39.0	7.0	Yes	39.0	7.0	0.212	7.5	-7%
NZ Army	7 Whites Rd	100	126.7	16.6	1.5	4.0	1960	1989	39	5.5	No	Yes	39.0	5.5	Yes	39.0	5.5	0.141	6.8	-38%
NZ Army	Moa St Line	100	130.6	18.9	4.5	6.0	1960	1989	39	10.5	No	Yes	39.0	10.5	Yes	39.0	10.5	0.269	8.9	19%
NZ Army	Pullack Road	100	126.5	17.4	3.5	4.5	1942	2000	58	8.0	No	Yes	58.0	8.0	Yes	58.0	8.0	0.138	13.2	-39%
NZ Army	12 Kipeneberger	150	181.5	17.6	5.0	1.0	1955	2000	45	6.0	No	Yes	45.0	6.0	Yes	45.0	6.0	0.133	10.2	-41%
NZ Army	627 Dimers Road	150	179.0	16.3	4.5	5.0	1973	2000	27	9.5	No	Yes	27.0	9.5	Yes	27.0	9.5	0.352	6.1	55%
NZ Army	Fosteres Road	150	179.0	16.3	5.0	4.5	1967	2000	33	9.5	No	Yes	33.0	9.5	Yes	33.0	9.5	0.288	7.5	27%
NZ Army	X27 Doherty Ave Lower	150	183.9	21.0	1.2	6.0	1960	1969	39	7.2	No	Yes	39.0	7.2	Yes	39.0	7.2	0.182	9.8	-15%
NZ Army	E17 Doherty Ave Upper	200	232.0	20.0	1.2	5.0	1960	2000	40	6.5	No	Yes	40.0	6.5	Yes	40.0	6.5	0.236	9.1	-8%
Porua CC	123 Chapman St	50	74.5	4.7	4.0	2.0	1956	1989	43	6.2	No	No	43.0	6.2	Yes	43.0	6.2	0.144	9.6	-39%
Porua CC	31 Chapman St	50	75.2	4.1	1.9	1.9	1956	1989	43	3.8	No	No	43.0	3.8	Yes	43.0	3.8	0.088	9.9	-51%
Porua CC	39 Levant Cres	50	72.9	1.5	3.2	2.5	1965	1989	34	5.7	No	Yes	34.0	5.7	Yes	34.0	5.7	0.168	7.7	-26%
Porua CC	Teora Terrace	100	124.1	12.4	2.3	3.5	1956	1989	43	6.4	No	Yes	43.0	6.4	Yes	43.0	6.4	0.149	9.8	-34%
Porua CC	Whareroa	100	124.4	13.7	1.8	3.5	1956	1989	40	5.3	No	Yes	40.0	5.3	Yes	40.0	5.3	0.133	9.1	-42%
Porua CC	4 Whareroa	150	180.0	12.6	2.0	4.3	1962	1989	36	6.7	No	Yes	36.0	6.7	Yes	36.0	6.7	0.176	6.6	22%
Porua CC	4 Whareroa St	150	180.0	12.6	2.0	4.3	1962	1989	36	6.7	No	Yes	36.0	6.7	Yes	36.0	6.7	0.176	6.6	22%
Porua CC	Winners Ave	150	182.6	21.2	2.6	3.3	1964	1989	45	9.2	No	Yes	45.0	9.2	Yes	45.0	9.2	0.136	10.2	-39%
Porua CC	Springston Pipeline	100	123.0	14.0	3.5	4.0	1966	2000	32	7.5	No	Yes	32.0	7.5	Yes	32.0	7.5	0.234	7.3	3%
Porua CC	Paupo Street	100	123.4	10.6	6.0	5.0	1960	2000	40	11.0	No	Yes	40.0	11.0	Yes	40.0	11.0	0.275	9.1	21%
Porua CC	Mangakino	225	269.0	28.2	0.5	10.2	1947	2000	53	0.7	No	Yes	53.0	0.7	Yes	53.0	0.7	0.202	12.0	-11%
Porua CC	Avenue Rd	100	70.3	9.9	2.0	4.0	1962	1989	37	6.0	No	Yes	37.0	6.0	Yes	37.0	6.0	0.162	3.4	29%
Porua CC	Evans St	50	72.1	10.8	4.0	4.5	1965	1989	34	8.5	No	Yes	34.0	8.5	Yes	34.0	8.5	0.250	7.7	10%
Porua CC	Miro St	50	72.8	11.3	6.0	4.0	1985	1989	14	10.0	Yes	Yes	14.0	10.0	Yes	14.0	10.0	FALSE	FALSE	FALSE
Porua CC	North St	50	73.7	11.6	2.5	4.5	1950	1989	49	7.0	No	Yes	49.0	7.0	Yes	49.0	7.0	0.143	11.1	-37%
Porua CC	Sophia St (outside Timaru Mts)	50	70.8	10.1	3.0	6.0	1967	1989	32	9.0	No	No	32.0	9.0	Yes	32.0	9.0	0.281	7.3	24%
Porua CC	Andrew St	100	127.7	16.2	4.5	7.0	1952	1989	47	11.5	No	Yes	47.0	11.5	Yes	47.0	11.5	0.245	10.7	8%
Porua CC	Clyde Carr Cres. (23 Luxmoore Rd)	100	124.0	13.1	4.5	5.0	1967	1989	32	9.5	No	Yes	32.0	9.5	Yes	32.0	9.5	0.287	7.3	31%
Porua CC	Fleming St	100	124.0	14.0	3.5	4.0	1975	1989	24	7.5	No	No	24.0	7.5	Yes	24.0	7.5	0.313	5.4	38%
Porua CC	George St	100	119.1	14.1	7.0	5.5	1956	1989	43	12.5	No	Yes	43.0	12.5	Yes	43.0	12.5	0.291	9.8	28%
Porua CC	Gouds Rd (BLUE)	100	127.8	13.8	4.5	4.5	1957	1989	42	9.0	No	Yes	42.0	9.0	Yes	42.0	9.0	0.214	9.5	-6%
Porua CC	Guise St	100	126.8	14.4	3.0	3.0	1989	1989	10	6.0	No	No	10.0	6.0	Yes	10.0	6.0	0.600	2.3	164%
Porua CC	Jane St (Historic 698)	100	122.0	11.7	3.5	8.0	1980	1989	39	11.5	No	No	39.0	11.5	Yes	39.0	11.5	0.295	4.8	30%
Porua CC	Morgan Rd New Life Centre	100	124.1	13.1	3.0	4.5	1980	1989	19	7.5	No	No	19.0	7.5	Yes	19.0	7.5	0.395		

Deterioration Model Calculations

Local Authority	Input from National Data Base										Calculations Based on Sample Data										Det'n Chart Input										Det'n Model Output	
	Location Description	City/Town	Pipe DN (mm)	Pipe OD (mm)	Min. Pipe WT (measured) (mm)	Max. External Det'n (mm)	Max. Internal Det'n (mm)	Year of Installation	Year of Appraisal	Sample Age (years)	Total Det'n (mm)	Without Result from Det'n Model?	Includes in Model (90%)	Sample Age (years)	Total Det'n (mm)	Includes in Model (85%)	Sample Age (years)	Total Det'n (mm)	Results to Include in Model (100%)	Sample Age (years)	Total Det'n (mm)	Results to Include in Model (100%)	Sample Age (years)	Total Det'n (mm)	Sample Det'n Rate (mm/year)	Modelled Det'n (mm)	Comparison with National Average					
Timaru DC	Somerset St	Timaru	100	126.5	17.0	2.0	5.5	1955	1989	44	7.5	No	No	44.0	7.5	Yes	44.0	7.5	Yes	44.0	7.5	Yes	44.0	7.5	0.170	10.0	-25%					
Timaru DC	Bridges Street	Gerardine	150	178.0	17.5	6.4	6.4	1956	1989	43	14.4	No	No	43.0	14.4	Yes	43.0	14.4	Yes	43.0	14.4	Yes	43.0	14.4	0.335	9.8	48%					
Timaru DC	Buller St	Timaru	150	180.0	12.1	3.0	3.0	1974	1989	25	6.0	No	Yes	25.0	6.0	Yes	25.0	6.0	Yes	25.0	6.0	Yes	25.0	6.0	0.240	5.7	48%					
Timaru DC	Dee St	Timaru	150	178.0	16.0	3.0	4.0	1979	1989	20	7.0	No	No	20.0	7.0	Yes	20.0	7.0	Yes	20.0	7.0	Yes	20.0	7.0	0.350	4.5	54%					
Timaru DC	Forest Rd	Gerardine	150	180.0	12.4	4.5	5.0	1972	1989	27	9.5	No	No	27.0	9.5	Yes	27.0	9.5	Yes	27.0	9.5	Yes	27.0	9.5	0.352	6.1	54%					
Timaru DC	Grey Rd	Timaru	150	178.2	15.1	1.5	2.5	1983	1989	16	4.0	No	No	16.0	4.0	Yes	16.0	4.0	Yes	16.0	4.0	Yes	16.0	4.0	0.250	3.6	10%					
Timaru DC	Hilton Highway	Timaru	150	178.0	15.7	6.0	4.0	1966	2000	34	10.0	No	No	34.0	10.0	Yes	34.0	10.0	Yes	34.0	10.0	Yes	34.0	10.0	0.294	7.7	30%					
Timaru DC	King St, Redgway	Timaru	150	178.0	14.3	6.0	6.0	1960	1989	39	12.0	No	No	39.0	12.0	Yes	39.0	12.0	Yes	39.0	12.0	Yes	39.0	12.0	0.308	6.8	36%					
Timaru DC	Lachlan St	Timaru	150	178.0	15.6	4.0	4.5	1966	1989	33	8.5	No	Yes	33.0	8.5	Yes	33.0	8.5	Yes	33.0	8.5	Yes	33.0	8.5	0.258	7.3	14%					
Timaru DC	Flanders St	Timaru	200	238.9	20.2	3.0	3.5	1980	1989	19	6.5	No	No	19.0	6.5	Yes	19.0	6.5	Yes	19.0	6.5	Yes	19.0	6.5	0.342	4.3	51%					
Timaru DC	Hastead Rd	Timaru	200	233.5	19.0	3.5	6.0	1964	1989	35	9.5	No	Yes	35.0	9.5	Yes	35.0	9.5	Yes	35.0	9.5	Yes	35.0	9.5	0.271	7.9	20%					
Timaru DC	Hilton Highway, Meadows Rd	Timaru	200	234.0	18.8	4.5	7.0	1966	1989	33	11.5	No	No	33.0	11.5	Yes	33.0	11.5	Yes	33.0	11.5	Yes	33.0	11.5	0.348	7.5	54%					
Timaru DC	Hilton Highway, Outside NZ Safety Ltd	Timaru	200	234.0	18.3	3.5	5.5	1966	1989	33	9.0	No	No	33.0	9.0	Yes	33.0	9.0	Yes	33.0	9.0	Yes	33.0	9.0	0.273	7.5	20%					
Timaru DC	Meadows, Waiwaka, Ch. B.	Timaru	200	232.3	19.0	3.5	4.0	1966	1989	33	7.5	No	No	33.0	7.5	Yes	33.0	7.5	Yes	33.0	7.5	Yes	33.0	7.5	0.227	7.5	0%					
Timaru DC	Richmond Road	Timaru	200	232.5	19.1	2.0	6.2	1969	1989	31	12.5	No	No	31.0	12.5	Yes	31.0	12.5	Yes	31.0	12.5	Yes	31.0	12.5	0.417	6.8	84%					
Timaru DC	Old North Rd & Andrew St	Timaru	250	281.9	23.1	5.0	4.5	1965	1989	34	8.5	No	Yes	34.0	8.5	Yes	34.0	8.5	Yes	34.0	8.5	Yes	34.0	8.5	0.279	7.7	23%					
Timaru DC	Orari Pipeline (near Res.)	Gerardine	250	292.7	23.3	4.5	5.0	1975	1989	24	9.5	No	No	24.0	9.5	Yes	24.0	9.5	Yes	24.0	9.5	Yes	24.0	9.5	0.386	5.4	74%					
Timaru DC	Orari Pipeline (near Res.)	Timaru	250	285.0	22.0	4.5	5.0	1966	1989	33	9.5	No	No	33.0	9.5	Yes	33.0	9.5	Yes	33.0	9.5	Yes	33.0	9.5	0.288	5.5	74%					
Timaru DC	Orari Pipeline (near Res.)	Timaru	250	285.0	22.0	4.5	5.0	1966	1989	33	9.5	No	No	33.0	9.5	Yes	33.0	9.5	Yes	33.0	9.5	Yes	33.0	9.5	0.192	5.9	15%					
Timaru DC	Hilton Highway, Waiwaka	Timaru	300	349.7	28.4	1.0	4.0	1973	1989	26	5.0	No	No	26.0	5.0	Yes	26.0	5.0	Yes	26.0	5.0	Yes	26.0	5.0	0.129	7.7	23%					
Upper Hut CC	Otapu Rd	Timaru	300	349.3	28.8	4.5	5.0	1965	1989	34	9.5	No	Yes	34.0	9.5	Yes	34.0	9.5	Yes	34.0	9.5	Yes	34.0	9.5	0.279	7.7	23%					
Upper Hut CC	1 Birch Grove	Upper Hut	100	123.0	13.0	1.2	6.7	1954	1982	38	7.9	No	Yes	38.0	7.9	Yes	38.0	7.9	Yes	38.0	7.9	Yes	38.0	7.9	0.208	8.6	-8%					
Upper Hut CC	10 Whitehall Grove	Upper Hut	100	124.5	13.5	2.0	3.0	1967	1982	25	5.0	No	Yes	25.0	5.0	Yes	25.0	5.0	Yes	25.0	5.0	Yes	25.0	5.0	0.200	5.7	-12%					
Upper Hut CC	2 Birch Grove	Upper Hut	100	125.7	14.0	3.0	2.0	1967	1982	25	5.0	No	Yes	25.0	5.0	Yes	25.0	5.0	Yes	25.0	5.0	Yes	25.0	5.0	0.200	5.7	-12%					
Upper Hut CC	21 Pinehill Crescent	Upper Hut	100	121.0	13.0	7.0	1.5	1954	1982	39	8.5	No	Yes	39.0	8.5	Yes	39.0	8.5	Yes	39.0	8.5	Yes	39.0	8.5	0.218	8.8	-4%					
Upper Hut CC	Barton Road	Upper Hut	100	127.7	17.0	2.5	3.5	1962	1982	30	6.0	No	Yes	30.0	6.0	Yes	30.0	6.0	Yes	30.0	6.0	Yes	30.0	6.0	0.200	8.8	-4%					
Upper Hut CC	Barton Road	Upper Hut	100	127.7	16.0	1.0	8.0	1954	1982	38	9.0	No	Yes	38.0	9.0	Yes	38.0	9.0	Yes	38.0	9.0	Yes	38.0	9.0	0.237	8.6	4%					
Upper Hut CC	Birch Grove	Upper Hut	100	121.9	13.0	5.5	1.2	1964	1982	38	6.7	No	Yes	38.0	6.7	Yes	38.0	6.7	Yes	38.0	6.7	Yes	38.0	6.7	0.176	8.6	-22%					
Upper Hut CC	Golders Road	Upper Hut	100	130.0	13.0	3.5	8.5	1950	1983	43	12.0	No	Yes	43.0	12.0	Yes	43.0	12.0	Yes	43.0	12.0	Yes	43.0	12.0	0.279	9.8	-2%					
Upper Hut CC	Josephs Cross	Upper Hut	100	123.0	13.0	4.5	4.2	1953	1982	39	8.7	No	Yes	39.0	8.7	Yes	39.0	8.7	Yes	39.0	8.7	Yes	39.0	8.7	0.223	6.8	-2%					
Upper Hut CC	McMurtre Grove	Upper Hut	100	127.8	18.2	3.0	3.5	1962	1982	30	6.5	No	Yes	30.0	6.5	Yes	30.0	6.5	Yes	30.0	6.5	Yes	30.0	6.5	0.147	6.8	-5%					
Upper Hut CC	Winchester Avenue	Upper Hut	100	124.0	13.0	2.6	2.8	1954	1982	38	5.4	No	Yes	38.0	5.4	Yes	38.0	5.4	Yes	38.0	5.4	Yes	38.0	5.4	0.142	8.6	-37%					
Upper Hut CC	105 Pinehaven Road	Upper Hut	150	179.0	16.0	7.0	3.5	1953	1982	31	10.5	No	Yes	31.0	10.5	Yes	31.0	10.5	Yes	31.0	10.5	Yes	31.0	10.5	0.269	8.8	18%					
Upper Hut CC	11 Wainman Road	Upper Hut	150	179.0	12.0	0.2	2.6	1973	1984	21	2.8	No	No	21.0	2.8	Yes	21.0	2.8	Yes	21.0	2.8	Yes	21.0	2.8	0.133	4.8	-41%					
Upper Hut CC	35 Wainman Road	Upper Hut	150	179.3	16.3	4.3	3.3	1973	2000	27	7.5	No	Yes	27.0	7.5	Yes	27.0	7.5	Yes	27.0	7.5	Yes	27.0	7.5	0.278	6.1	22%					
Upper Hut CC	70 Wainman Road	Upper Hut	150	179.3	16.0	7.0	3.0	1953	1982	39	10.0	No	Yes	39.0	10.0	Yes	39.0	10.0	Yes	39.0	10.0	Yes	39.0	10.0	0.263	6.8	13%					
Upper Hut CC	82 Pinehaven Road	Upper Hut	150	179.3	16.0	2.0	2.3	1953	1982	39	6.0	No	No	39.0	6.0	Yes	39.0	6.0	Yes	39.0	6.0	Yes	39.0	6.0	0.158	3.8	-43%					
Upper Hut CC	82/84 Pinehaven Road	Upper Hut	150	179.3	16.0	2.0	2.3	1953	1982	39	6.0	No	No	39.0	6.0	Yes	39.0	6.0	Yes	39.0	6.0	Yes	39.0	6.0	0.123	3.8	-43%					
Upper Hut CC	Araro Road	Upper Hut	150	185.0	20.0	1.5	8.5	1942	1981	49	10.0	No	No	49.0	10.0	Yes	49.0	10.0	Yes	49.0	10.0	Yes	49.0	10.0	0.204	11.1	10%					
Upper Hut CC	Ben Street	Upper Hut	150	185.0	16.0	1.5	8.0	1947	1981	44	9.5	No	No	44.0	9.5	Yes	44.0	9.5	Yes	44.0	9.5	Yes	44.0	9.5	0.216	10.0	10%					
Upper Hut CC	Elmslie Road	Upper Hut	150	180.0	16.0	6.2	3.5	1953	1983	40	9.7	No	No	40.0	9.7	Yes	40.0	9.7	Yes	40.0	9.7	Yes	40.0	9.7	0.243	9.1	7%					
Upper Hut CC	Maymorn Road - Pig Farm	Upper Hut	150	179.6	16.8	8.0	3.5	1973	2000	27	11.5	No	No	27.0	11.5	Yes	27.0	11.5	Yes	27.0	11.5	Yes	27.0	11.5	0.426	5.1	88%					
Upper Hut CC	Wyntham Road	Upper Hut	100	130.0	16.0	7.5	2.8	1953	1984	41	10.3	No	Yes	41.0	10.3	Yes	41.0	10.3	Yes	41.0	10.3	Yes	41.0	10.3	0.251	9.3	11%					
Waikato DC	Bailey St	Hurly	100	130.0	18.2	0.5	3.0	1943	1989	56	3.5	No	Yes	56.0	3.5	Yes	56.0	3.5	Yes	56.0	3.5	Yes	56.0	3.5	0.046	10.0	88%					
Waikato DC	Croft Tce	Hurly	100	129.9	13.5	5.5	2.5	1980	1989	19	9.0	No	Yes	19.0	9.0	Yes	19.0	9.0	Yes	19.0	9.0	Yes	19.0	9.0	0.421	4.3	86%					
Waikato DC	Eley St	Ngaruawahia	100	122.5	13.3	6.5	5.0	1973	1989	26	11.5	No	No	26.0	11.5	Yes	26.0	11.5	Yes	26.0	11.5	Yes	26.0	11.5	0.442	5.9						



Deterioration Model Calculations

Input from National Date Base										Calculations Based on Sample Data					Det'n Chart Input						Det'n Model Output		
Local Authority	Location Description	City/Town	Pipe DN (mm)	Pipe OD (mm)	Min. Pipe Wt (measured) (mm)	Max. External Det'n (mm)	Max. Internal Det'n (mm)	Year of Installation	Year of Appraisal	Sample Age (years)	Total Det'n (mm)	Without Result from Det'n Model?	Results to Include in Model (90%)	Sample Age (years)	Total Det'n (mm)	Results to Include in Model (100%)	Sample Age (years)	Total Det'n (mm)	Sample Det'n Rate (mm/year)	Modelled Det'n (mm)	Comparison with National Average		
Waipa DC	Hamilton Rd	Cambridge	200	233.0	23.8	5.5	4.0	0	2000	2000	9.5	Yes	No	FALSE	FALSE	No	FALSE	FALSE	FALSE	453.8	-98%		
Waikare CC	10 Hewitt St	Waikare	50	73.4	11.6	5.0	0.0	1968	1988	30	5.0	No	No	FALSE	FALSE	Yes	30.0	5.0	0.167	6.8	-27%		
Waikare CC	111 Ferry Pde	Waikare	50	71.9	11.3	4.0	3.0	1965	1988	13	7.0	No	No	FALSE	FALSE	Yes	13.0	7.0	0.538	2.9	137%		
Waikare CC	36 Durham Rd	Waikare	50	74.3	11.9	6.0	2.5	1959	1988	39	8.5	No	Yes	FALSE	FALSE	Yes	39.0	8.5	0.218	8.8	-4%		
Waikare CC	40 Rimutaka St	Waikare	50	70	9	3	0	1963	1988	35	3.0	No	No	FALSE	FALSE	Yes	35.0	3.0	0.086	7.9	0%		
Waikare CC	428 Don Buck Rd	Waikare	30	73	11.8	4	3.5	1965	1988	33	7.5	No	Yes	FALSE	FALSE	Yes	33	7.5	0.227	7.5	0%		
Waikare CC	5 Brans Rd	Waikare	37	72	10.8	6	0	1961	1988	37	6	No	No	FALSE	FALSE	Yes	37	6	0.162	6.4	-57%		
Waikare CC	51 Cronin Ave	Waikare	41	73.1	11.6	4	0	1957	1988	41	4	No	No	FALSE	FALSE	Yes	41	4	0.098	9.3	-57%		
Waikare CC	65 Farquhar St	Waikare	50	72.6	12.2	4	2	1958	1988	40	6	No	No	FALSE	FALSE	Yes	40	6	0.150	9.1	-34%		
Waikare CC	9 Granger Rd	Waikare	50	74.1	9.8	6	0	1962	1988	42	3	No	No	FALSE	FALSE	Yes	42	3	0.143	9.5	-37%		
Waikare CC	95 Rahapar Rd	Waikare	50	74.1	12.3	3	0	1962	1988	36	3	No	No	FALSE	FALSE	Yes	36	3	0.063	9.2	-63%		
Waikare CC	123 Bedford St	Waikare	100	125	14.3	4	0	1964	1988	34	4	No	No	FALSE	FALSE	Yes	34	4	0.118	7.7	-48%		
Waikare CC	15 Neal Ave	Waikare	100	123.9	16.4	6	2	1956	1988	42	8	No	Yes	FALSE	FALSE	Yes	42	8	0.190	9.5	-16%		
Waikare CC	16 Valley Rd	Waikare	100	124	13.7	2	0	1960	1988	9	3	No	No	FALSE	FALSE	Yes	9	3	0.444	2.0	98%		
Waikare CC	20 Valley Rd	Waikare	100	126.5	17.3	4	0	1950	1988	38	4	No	No	FALSE	FALSE	Yes	38	4	0.083	10.0	96%		
Waikare CC	220 Coth Ave	Waikare	100	126.4	14	5	0	1959	1988	39	5	No	No	FALSE	FALSE	Yes	39	5	0.128	9.8	-33%		
Waikare CC	23 Kolin St	Waikare	100	125.9	15.5	7	0	1953	1988	45	4	No	No	FALSE	FALSE	Yes	45	4	0.089	10.2	-51%		
Waikare CC	24 Terra Nova Pl	Waikare	100	123.7	13.2	4	0	1974	1988	24	4	No	Yes	FALSE	FALSE	Yes	24	4	0.167	5.4	-27%		
Waikare CC	28 Eastglen Rd	Waikare	100	125.1	14.7	5	0	1966	1988	32	6	No	Yes	FALSE	FALSE	Yes	32	6	0.188	7.3	-27%		
Waikare CC	3 Nicholas Ave	Waikare	100	124.2	13.6	5	0	1967	1988	31	5	No	Yes	FALSE	FALSE	Yes	31	5	0.161	7.0	-29%		
Waikare CC	51 Oneidin St	Waikare	100	121.8	13.6	5	2.5	1984	1988	14	7.5	No	No	FALSE	FALSE	Yes	14	7.5	0.536	3.2	136%		
Waikare CC	55 Donovin Dr	Waikare	100	121.7	13.5	4	0	1976	1988	22	4	No	Yes	FALSE	FALSE	Yes	22	4	0.182	5.0	-20%		
Waikare CC	59 Chilcot Ave	Waikare	100	122.7	13.3	6	0	1969	1988	29	6	No	Yes	FALSE	FALSE	Yes	29	6	0.207	6.6	-9%		
Waikare CC	65 Tanekaha Rd	Waikare	100	126.9	12.7	5	5	1989	1988	9	10	Yes	No	FALSE	FALSE	Yes	9	10	0.207	2.0	390%		
Waikare CC	Frank Evans Pl	Waikare	100	123.8	13.9	4	0	1982	1988	16	4	No	Yes	FALSE	FALSE	Yes	16	4	0.250	3.6	10%		
Waikare CC	13 Lagoon Way	Waikare	150	179	16.4	4	0	1966	1988	12	4	No	No	FALSE	FALSE	Yes	12	4	0.333	2.7	47%		
Waikare CC	14 Warwick St	Waikare	150	127.9	19.4	3	4	1971	1988	27	7	No	Yes	FALSE	FALSE	Yes	27	7	0.259	6.1	14%		
Waikare CC	33 Luanda Dr	Waikare	150	179	16.7	5	0	1975	1988	23	5	No	Yes	FALSE	FALSE	Yes	23	5	0.217	5.2	-4%		

Deterioration Model Chart
(based on data contained in "Detn Model (Calcs)")

Note: Excludes samples withheld from Deterioration Relationship

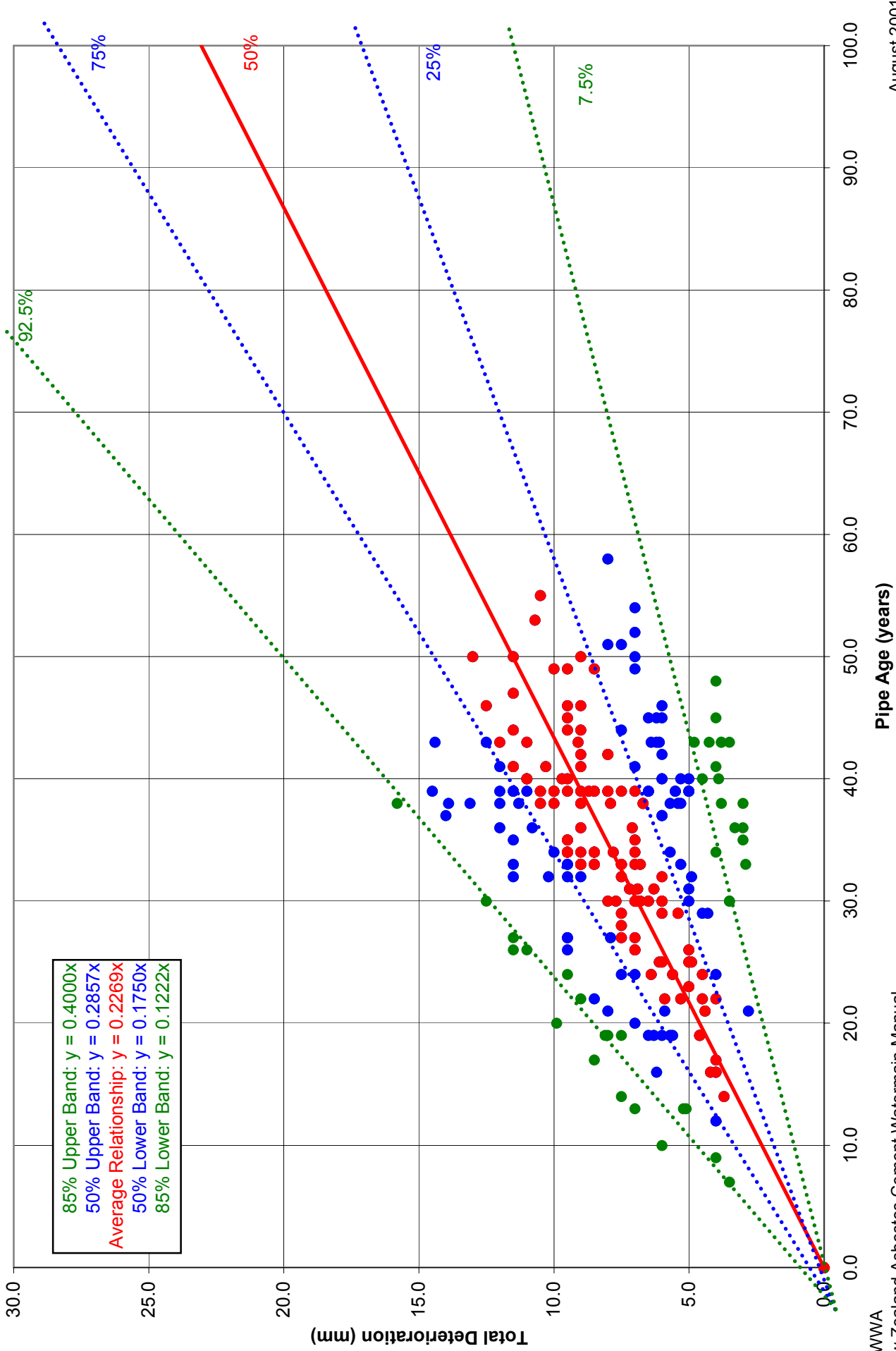



Input from National Data Base										Calculations Based on Sample Data					Deterioration Model Output			Lifetime Prediction Model Output	
Local Authority	Location Description	City/Town	Pipe DN (mm)	Mean Pipe OD (mm)	Min. Pipe Wall Thickness (mm)	Working Pressure (m)	Total Det'n (mm)	Year of Installation	Year of Appraisal	Sample Age (years)	Working Pressure + Surge (MPa)	Minimum Undeteriorated Wt before failure (mm)	Total Det'n Causing Failure (mm)	Sample Det'n Rate (mm/year)	Modelled Det'n (mm)	Comparison with National Average	Estimated Pipe Life (years)	Estimated Year of First Det'n Failure	
Ashburton DC	John St	Ashburton	100	128.2	18.3	56	7.0	1969	1999	30	0.82	2.1	16.3	0.233	6.8	3%	70	2039	
Ashburton DC	Thompson St	Ashburton	100	123.0	11.5	55	7.0	1969	1999	30	0.81	2.0	9.5	0.233	6.8	3%	41	2010	
Ashburton DC	Trevars Rd	Ashburton	100	123.0	11.2	61	6.0	1969	1999	30	0.90	2.2	9.0	0.200	6.8	-12%	45	2014	
Ashburton DC	Farm Rd	Ashburton	150	178.5	12.2	59	9.0	1965	1999	34	0.87	1965	9.1	0.265	7.7	17%	35	2000	
Ashburton DC	Farm Rd	Ashburton	150	179.9	12.3	45	8.0	1969	1999	30	0.66	2.3	10.0	0.267	6.8	18%	37	2006	
Ashburton DC	McNally St	Ashburton	200	235.7	15.9	55	7.0	1973	1997	24	0.81	3.7	12.1	0.292	5.4	25%	42	2015	
Carterton DC	Carterton	Carterton	100	124.4	16.9	67	14.0	1960	1997	37	0.98	2.4	14.5	0.378	8.4	67%	38	1998	
Christchurch CC	Ayr Street	Christchurch	100	127.0	17.7	58	3.0	1961	1999	38	0.85	2.1	15.6	0.079	8.6	-65%	100	2061	
Christchurch CC	Brynley Street	Christchurch	100	124.1	11.0	47	6.5	1960	1999	39	0.69	1.7	9.3	0.167	8.8	-27%	56	2016	
Christchurch CC	Euston Street	Christchurch	100	126.2	17.5	58	8.5	1950	1999	49	0.85	2.1	15.4	0.173	11.1	-24%	89	2039	
Christchurch CC	Hansons Lane	Christchurch	100	128.0	18.2	48	8.0	1960	1999	39	0.70	1.8	16.4	0.205	8.8	-10%	80	2040	
Christchurch CC	Hineu Place	Christchurch	100	125.0	13.5	72	6.5	1950	2001	51	1.06	2.6	10.9	0.127	11.6	-4%	86	2036	
Christchurch CC	87 Hollis Avenue	Christchurch	100	123.5	14.0	46	4.5	1986	2001	15	0.68	1.6	12.4	0.300	3.4	32%	41	2027	
Christchurch CC	114 Hollis Avenue	Christchurch	100	123.5	14.0	46	5.0	1986	2001	15	0.68	1.6	12.4	0.300	3.4	47%	37	2023	
Christchurch CC	Hood Street	Christchurch	100	127.5	17.7	70	7.0	1945	1999	54	1.03	2.6	15.2	0.130	12.3	-43%	100	2045	
Christchurch CC	Hooker Avenue	Christchurch	100	128.8	17.0	40	6.5	1960	1999	39	0.59	1.5	15.5	0.167	8.8	-27%	93	2053	
Christchurch CC	Kibblewhite Street	Christchurch	100	127.0	18.0	68	8.0	1949	2000	51	1.00	2.5	15.5	0.157	11.6	-31%	99	2048	
Christchurch CC	Krowles Street	Christchurch	100	130.3	18.1	54	12.0	1947	1999	52	0.79	2.0	16.1	0.231	11.8	2%	70	2017	
Christchurch CC	Matal Street West	Christchurch	100	127.0	17.6	72	7.0	1950	2000	50	1.05	2.6	15.0	0.140	11.3	-38%	100	2050	
Christchurch CC	Nelson Street	Christchurch	100	127.0	18.0	72	13.0	1950	2000	50	1.05	2.6	15.3	0.260	11.3	15%	59	2009	
Christchurch CC	Ocean View Terrace	Christchurch	100	119.0	14.7	66	6.0	1953	1999	46	0.97	2.3	12.4	0.130	10.4	-43%	95	2048	
Christchurch CC	Poynder Ave	Christchurch	100	123.0	13.1	40	9.5	1960	1999	39	0.59	1.4	11.7	0.244	8.8	7%	46	2008	
Christchurch CC	Straven Road	Christchurch	100	123.8	13.0	40	8.5	1965	1999	34	0.59	1.4	11.5	0.250	7.7	10%	46	2011	
Christchurch CC	Takaha Drive	Christchurch	100	123.0	12.6	41	4.0	1955	2001	46	0.60	1.5	11.1	0.087	10.4	-62%	100	2055	
Christchurch CC	Tui Street	Christchurch	100	125.0	13.4	40	9.0	1955	1999	44	0.59	1.5	11.9	0.205	10.0	-10%	58	2013	
Christchurch CC	Tyrone Street	Christchurch	100	123.0	11.1	40	7.0	1965	1999	34	0.59	1.4	9.7	0.206	7.7	-9%	47	2012	
Christchurch CC	Wai-l-i Street	Christchurch	100	124.5	11.8	51	4.5	1960	2000	40	0.75	1.8	10.0	0.113	9.1	-50%	89	2049	
Christchurch CC	Cyber Road	Christchurch	150	181.0	12.5	40	4.5	1975	1999	24	0.59	2.1	10.4	0.188	5.4	-17%	59	2030	
Christchurch CC	Cyber Road	Christchurch	150	179.0	15.8	51	12.0	1960	2001	41	0.75	2.6	13.2	0.293	9.3	29%	45	2005	
Christchurch CC	Gilberthorpes Road	Christchurch	150	179.3	11.6	35	7.5	1948	1999	51	0.51	1.8	9.8	0.147	11.6	-35%	66	2014	
Christchurch CC	Handwick Street	Christchurch	150	180.3	15.4	70	6.0	1980	1999	19	1.03	3.6	11.8	0.316	4.3	39%	37	2017	
Christchurch CC	Lydia Street	Christchurch	150	180.8	17.7	72	6.0	1980	2000	40	1.05	3.7	14.0	0.150	9.1	-34%	93	2053	
Christchurch CC	Lydia Street	Christchurch	150	180.4	16.5	40	8.5	1982	1999	17	0.59	1982	14.4	0.500	3.9	120%	29	2011	
Christchurch CC	Mapo Street	Christchurch	150	181.5	20.8	58	9.5	1950	1999	49	0.85	3.0	17.8	0.194	11.1	-15%	92	2042	
Christchurch CC	Rawson Street	Christchurch	150	178.0	18.7	72	1.5	1940	2001	61	1.06	3.7	15.0	0.025	13.8	-89%	100	2040	
Christchurch CC	Waimari Road	Christchurch	150	180.5	16.2	40	11.0	1960	1999	39	0.59	2.1	14.1	0.282	8.8	24%	50	2010	
Christchurch CC	Wierimu Street	Christchurch	150	181.1	16.7	40	9.0	1977	1999	22	0.59	2.1	14.6	0.409	5.0	80%	36	2013	
Christchurch CC	Avonmead Road	Christchurch	200	230.0	20.7	55	12.0	1960	2001	41	0.81	3.7	17.0	0.293	9.3	25%	58	2018	
Christchurch CC	Belfast Road	Christchurch	200	234.0	15.6	40	7.5	1966	2000	34	0.59	2.7	12.9	0.279	7.7	23%	46	2012	
Christchurch CC	Byron Street	Christchurch	200	235.0	19.9	70	9.5	1972	2000	28	1.03	4.7	15.1	0.288	6.4	18%	56	2028	
Christchurch CC	Canford Street	Christchurch	200	233.9	18.7	63	9.0	1966	1999	33	0.93	4.2	14.5	0.273	7.5	20%	53	2019	
Christchurch CC	36 Curries Road	Christchurch	200	234.0	18.6	87	7.5	1940	2001	61	1.28	5.8	12.8	0.123	13.8	-46%	100	2040	
Christchurch CC	Fensholt Road	Christchurch	200	237.0	16.5	40	8.0	1979	2000	21	0.59	2.8	13.7	0.381	4.8	68%	36	2015	
Christchurch CC	Hollis Avenue	Christchurch	200	231.5	19.7	48	4.5	1977	1999	22	0.70	3.2	16.5	0.205	5.0	-10%	81	2058	
Christchurch CC	Main South Road Templeton P Station	Christchurch	200	234.7	15.4	65	4.4	1966	2000	34	0.95	4.4	11.0	0.229	7.7	1%	48	2014	
Christchurch CC	Queenspark Drive	Christchurch	200	236.0	20.1	38	7.0	1973	1999	26	0.56	2.6	17.5	0.269	5.9	19%	65	2038	
Christchurch CC	Springs Road	Christchurch	200	236.0	20.0	50	7.0	1958	1999	41	0.73	3.4	16.6	0.171	9.3	-25%	97	2055	
Christchurch CC	Station Road	Christchurch	200	234.0	19.4	40	6.5	1955	2000	45	0.59	2.7	16.7	0.144	10.2	-36%	100	2055	
Christchurch CC	Ernmett Street	Christchurch	225	262.0	28.9	70	7.0	1947	1999	52	1.03	5.3	23.6	0.135	11.8	-41%	100	2047	
Christchurch CC	Aynsley Terrace	Christchurch	300	346.0	27.2	70	8.5	1977	1999	22	1.03	7.0	20.2	0.386	5.0	70%	92	2029	



Input from National Data Base										Calculations Based on Sample Data					Deterioration Model Output			Lifetime Prediction Model Output	
Local Authority	Location Description	City/Town	Pipe DN (mm)	Mean Pipe OD (mm)	Min. Pipe Wall Thickness (mm)	Working Pressure (m)	Total Det'n (mm)	Year of Installation	Year of Appraisal	Sample Age (years)	Working Pressure + Surge (MPa)	Minimum Undeteriorated Wt before failure (mm)	Total Det'n Causing Failure (mm)	Sample Det'n Rate (mm/year)	Modelled Det'n (mm)	Comparison with National Average	Estimated Pipe Life (years)	Estimated Year of First Det'n Failure	
Christchurch CC	Darrock street	Christchurch	300	339.5	18.6	40	8.5	1965	1999	34	0.59	3.9	14.7	0.250	7.7	10%	59	2024	
Christchurch CC	Hills Road	Christchurch	300	344.0	25.1	70	5.5	1960	1999	39	1.03	6.9	18.2	0.141	8.8	38%	100	2060	
Christchurch CC	St Asaph Street	Christchurch	300	347.5	27.2	70	7.5	1970	1999	29	1.03	7.0	20.2	0.269	6.6	14%	78	2048	
Christchurch CC	Waivatu Street	Christchurch	300	347.0	19.0	51	7.0	1965	2000	35	0.75	5.1	13.9	0.200	7.9	-12%	69	2034	
Christchurch CC	Watts Road	Christchurch	300	339.0	18.2	42	8.0	1960	1999	39	0.62	4.1	14.0	0.205	8.8	-10%	68	2028	
Far North DC	140 Commerce St	Kaitiaki	100	124.3	15.9	72	10.0	1980	1998	38	1.05	2.6	13.3	0.263	8.6	16%	51	2011	
Far North DC	194 Commerce St	Kaitiaki	100	122.4	17.1	72	13.9	1960	1998	38	1.05	2.5	14.6	0.366	8.6	61%	40	2000	
Far North DC	Farrimond St	Kaitiaki	100	127.9	17.6	72	15.9	1960	1998	38	1.05	2.6	15.0	0.416	8.6	83%	36	1998	
Far North DC	Puckey Ave (Int. Taale St)	Kaitiaki	100	126.0	17.3	71	13.1	1960	1998	38	1.04	2.6	14.7	0.345	8.6	52%	43	2003	
Far North DC	195 Commerce St	Kaitiaki	150	179.7	15.9	72	5.3	1960	1998	38	1.05	3.7	12.2	0.139	8.6	-39%	88	2048	
Far North DC	44 Commerce St	Kaitiaki	150	179.8	21.3	72	11.3	1960	1998	38	1.05	3.7	17.6	0.297	8.6	31%	59	2019	
Gore DC	Otago Water Scheme	Gore	100	124.0	12.9	76	7.9	1972	1999	27	1.12	2.7	10.2	0.293	6.1	29%	35	2007	
Hauraki DC	Paeroa	Paeroa	300	349.0	23.2	75	11.5	1958	1999	41	1.10	7.5	15.7	0.280	9.3	24%	56	2014	
Hauraki DC	Paeroa	Paeroa	300	352.5	24.6	74	11.5	1958	1999	41	1.09	7.5	17.1	0.280	9.3	24%	61	2019	
Hauraki DC	Paeroa	Paeroa	300	349.0	24.0	60	12.0	1958	1999	41	0.88	6.0	18.0	0.283	9.3	29%	61	2019	
Invercargill CC	Dome Street	Invercargill	100	124.0	12.9	42	10.5	1962	2000	38	0.62	1.5	11.4	0.276	8.6	22%	41	2003	
Invercargill CC	Helmstade Street	Invercargill	100	124.5	13.3	40	12.0	1962	2000	38	0.73	1.8	11.5	0.316	8.6	39%	36	1998	
Invercargill CC	Islington Street	Invercargill	100	133.5	16.0	40	4.5	1941	2000	59	0.59	1.5	16.5	0.076	13.4	-56%	100	2041	
Invercargill CC	Jack Street	Invercargill	100	123.0	11.0	42	11.0	1957	2000	43	0.62	1.5	9.5	0.256	9.8	13%	37	1994	
Invercargill CC	Miller Street	Invercargill	100	125.0	16.3	45	11.5	1956	2000	44	0.66	1.6	14.7	0.261	10.0	15%	56	2012	
Invercargill CC	Mersey Street	Invercargill	150	183.0	17.5	55	9.0	1959	2000	41	0.81	2.9	14.6	0.220	9.3	-3%	66	2025	
M o E	Sample 1 (Fire Hydrant)	Invercargill	100	124.0	11.4	40	3.5	1959	1999	30	0.59	1.4	10.0	0.117	6.8	-49%	85	2054	
M o E	Sample 2 (Main Driveway)	Casebrook Int. Sch.	100	124.0	11.1	40	3.5	1969	1999	30	0.59	1.4	9.7	0.117	6.8	-49%	83	2052	
North Shore CC	Carneloi Pl	Glenfield	50	74.5	12.1	110	8.1	1979	1998	19	1.62	2.3	9.8	0.426	4.3	88%	23	2002	
North Shore CC	Harberg St	Glenfield	50	71.3	11.0	110	10.2	1966	1998	32	1.62	2.2	8.9	0.319	7.3	40%	27	1993	
North Shore CC	Helberg St	Glenfield	50	72.1	11.2	110	11.5	1966	1998	32	1.62	2.3	8.9	0.359	7.3	56%	25	1991	
North Shore CC	Hauraki Cres	Glenfield	50	71.7	11.0	80	6.8	1965	1998	33	1.17	1.6	9.3	0.206	7.5	-9%	45	2010	
North Shore CC	Hillside Rd	Glenfield	50	69.5	9.9	80	9.6	1978	1998	20	1.17	1.6	8.3	0.495	4.5	116%	17	1995	
North Shore CC	Nea Rd	Glenfield	50	72.2	11.6	110	5.3	1965	1998	33	1.62	2.3	9.3	0.161	7.5	-29%	58	2023	
North Shore CC	Stanaway St	Glenfield	50	72.3	11.2	110	4.9	1966	1998	32	1.62	2.3	8.9	0.153	7.3	-33%	58	2024	
North Shore CC	Sudan Ave	Wilton	50	71.8	10.8	80	10.9	1962	1998	36	1.17	1.6	9.2	0.300	8.2	32%	31	1993	
North Shore CC	Waiau St	Torbay	50	71.0	10.8	90	4.9	1973	1998	25	1.32	1.8	9.0	0.196	5.7	-14%	46	2019	
North Shore CC	Waitemata Rd	Takapuna	50	73.0	11.5	80	6.9	1967	1998	31	1.17	1.7	9.9	0.223	7.0	-2%	44	2011	
North Shore CC	Weldene Ave	Glenfield	50	75.5	13.0	110	4.3	1969	1998	29	1.62	2.4	10.6	0.148	6.6	-35%	72	2041	
North Shore CC	Weldene Ave	Glenfield	50	75.0	13.1	110	4.5	1969	1998	29	1.62	2.3	10.8	0.155	6.6	-32%	69	2038	
North Shore CC	Weldene Ave	Glenfield	50	75.0	13.2	110	5.4	1969	1998	29	1.62	2.3	10.9	0.186	6.6	-18%	58	2027	
North Shore CC	Felicity Pl	Glenfield	100	123.4	13.8	110	4.0	1981	1998	17	1.62	3.9	10.0	0.235	3.9	4%	42	2023	
North Shore CC	Gamer St	Glenfield	100	124.0	13.6	110	6.4	1974	1998	24	1.62	3.9	9.7	0.267	5.4	18%	36	2010	
North Shore CC	Hellers Rd	Glenfield	100	123.9	13.8	80	6.9	1968	1998	30	1.17	3.9	10.9	0.230	6.8	1%	47	2015	
North Shore CC	Laser Pl	Glenfield	100	123.3	14.0	110	4.4	1977	1998	21	1.62	3.9	10.1	0.210	4.8	-8%	48	2025	
North Shore CC	Mayall Ave	Glenfield	100	121.7	13.9	110	6.1	1973	1998	25	1.62	3.8	10.1	0.244	5.7	8%	41	2014	
North Shore CC	Merida Pl	Glenfield	100	124.1	13.7	110	6.2	1982	1998	16	1.62	3.9	9.8	0.388	3.6	71%	25	2007	
North Shore CC	Orton St	Glenfield	100	125.6	14.6	110	6.8	1968	1998	30	1.62	3.9	10.6	0.227	6.8	0%	47	2015	
North Shore CC	Randall Pl	Birkdale	100	123.3	13.9	135	5.6	1974	1998	24	1.98	4.7	9.2	0.233	5.4	3%	39	2013	
North Shore CC	Standish Pl	Glenfield	100	123.0	14.1	110	5.3	1976	1998	22	1.62	3.9	10.2	0.241	5.0	6%	43	2019	
North Shore CC	Tacius Pl	Glenfield	100	124.7	14.4	110	4.2	1982	1998	16	1.62	3.9	10.5	0.263	3.6	16%	40	2022	
North Shore CC	Taurus Cres	Birkdale	100	124.4	13.9	110	6.3	1967	1998	31	1.62	3.9	10.0	0.203	7.0	-10%	49	2016	
North Shore CC	Tesla Pl	Glenfield	100	122.2	13.7	110	4.6	1979	1998	19	1.62	3.8	9.9	0.300	4.3	32%	33	2012	
North Shore CC	Theban Pl	Glenfield	100	122.8	13.6	110	5.7	1979	1998	19	1.62	3.8	9.8	0.242	4.3	7%	40	2019	
North Shore CC	Unknown	Glenfield	100	123.4	13.4	80	7.7	1968	1998	30	1.17	2.8	10.5	0.257	6.8	13%	41	2009	
North Shore CC	Ashfield Rd	Glenfield	150	179.0	17.7	80	4.4	1977	1998	21	1.17	4.1	13.6	0.210	4.8	-8%	65	2042	



Input from National Data Base										Calculations Based on Sample Data					Deterioration Model Output			Lifetime Prediction Model Output	
Local Authority	Location Description	City/Town	Pipe DN (mm)	Mean Pipe OD (mm)	Min. Pipe Wall Thickness (mm)	Working Pressure (m)	Total Def'n (mm)	Year of Installation	Year of Appraisal	Sample Age (years)	Working Pressure + Surge (MPa)	Minimum Undeteriorated Wt before failure (mm)	Total Def'n Causing Failure (mm)	Sample Def'n Rate (mm/year)	Modelled Def'n (mm)	Comparison with National Average	Estimated Pipe Life (years)	Estimated Year of First Def'n Failure	
North Shore CC	Ashley Ave	Torbay	150	179.2	18.9	118	5.9	1977	1998	21	1.73	6.0	12.9	0.281	4.8	24%	46	2023	
North Shore CC	Athena Dr	Glenfield	150	179.0	16.7	110	5.2	1985	1998	13	1.62	5.6	11.1	0.400	2.9	76%	28	2013	
North Shore CC	Athena Dr	Glenfield	150	179.0	18.9	110	5.1	1985	1998	13	1.62	5.7	13.2	0.392	2.9	73%	34	2019	
North Shore CC	Bush Rd	Albany	150	181.6	17.4	85	6.3	1979	1998	19	1.25	4.4	13.0	0.332	4.3	46%	39	2018	
North Shore CC	Pemberton Ave	Glenfield	150	179.2	15.9	110	5.9	1976	1998	22	1.62	5.6	10.3	0.268	5.0	18%	38	2014	
North Shore CC	Santiago Cres	Glenfield	150	179.9	12.6	110	3.7	1994	1998	14	1.62	5.6	6.9	0.264	3.2	16%	26	2010	
North Shore CC	Trials Rd	Glenfield	150	178.5	15.8	110	4.6	1979	1998	19	1.62	5.6	10.2	0.242	4.3	7%	42	2021	
North Shore CC	Trials Rd	Glenfield	150	178.1	16.2	110	5.6	1979	1998	19	1.62	5.6	10.6	0.295	4.3	30%	36	2015	
NZ Army	6 Takrouna	Linton	100	124.0	11.6	41	7.0	1987	2000	33	0.60	1.5	10.1	0.212	7.5	-7%	48	2015	
NZ Army	7 Whites Rd	Burnham	100	126.7	16.6	28	5.5	1960	1999	39	0.40	1.0	15.6	0.141	8.8	-38%	100	2060	
NZ Army	Moia St line	Burnham	100	130.6	18.0	28	10.5	1960	1999	39	0.40	1.0	17.0	0.269	8.8	19%	63	2023	
NZ Army	Purikit Road	Linton	100	125.5	17.4	29	8.0	1942	2000	58	0.42	1.0	16.4	0.138	19.2	-39%	100	2042	
NZ Army	12 Kippenberger	Linton	150	181.5	17.6	29	6.0	1955	2000	45	0.42	1.5	16.1	0.133	10.2	-41%	100	2055	
NZ Army	B27 Dimers Road	Linton	150	179.0	16.3	29	9.5	1973	2000	27	0.42	1.5	14.8	0.352	6.1	55%	42	2015	
NZ Army	Fosters Road	Linton	150	179.0	16.5	29	9.5	1987	2000	33	0.42	1.5	15.0	0.288	7.5	27%	52	2019	
NZ Army	X37 Delivery line to tower	Burnham	150	183.9	21.9	38	7.5	1960	1999	39	0.55	2.0	19.9	0.192	8.8	-15%	100	2060	
NZ Army	E17 Rowlings Road	Linton	200	235.0	20.0	29	9.5	1960	2000	40	0.42	2.0	18.1	0.238	9.1	5%	76	2036	
Porirua CC	123 Champion St	Porirua	50	74.5	12.7	41	6.2	1956	1999	43	0.60	0.9	11.8	0.144	9.8	-36%	82	2038	
Porirua CC	34 Champion St	Porirua	50	73.2	11.4	56	3.8	1956	1999	43	0.83	1.2	10.2	0.088	9.8	-61%	100	2056	
Porirua CC	39 Levent Cres	Porirua	50	72.9	11.5	72	5.7	1965	1999	34	1.05	1.5	10.0	0.168	7.7	-26%	60	2025	
Porirua CC	8 Hazard Cr	Porirua	50	75.8	12.7	92	7.1	1963	1999	36	1.35	2.0	10.7	0.197	8.2	-13%	54	2017	
Porirua CC	8 Leicester St	Porirua	50	71.7	11.3	38	3.8	1961	1999	38	1.20	1.7	9.8	0.100	8.6	-58%	96	2057	
Porirua CC	Cnr Hazard Gr and Calliope St	Porirua	50	73.7	12.4	92	3.3	1963	1999	36	1.35	1.9	10.5	0.092	8.2	-60%	100	2063	
Porirua CC	Mungavin Avenue	Porirua	50	74.3	12.5	82	5.0	1959	1999	40	1.20	1.7	10.7	0.125	9.1	-45%	86	2045	
Porirua CC	17 York Pl	Porirua	100	126.5	17.1	61	5.7	1961	1999	38	0.90	2.2	14.9	0.150	8.6	-34%	99	2060	
Porirua CC	19-21 Cluny Rd	Porirua	100	124.1	12.2	77	3.5	1956	1999	43	1.13	2.7	9.5	0.081	9.8	-64%	100	2056	
Porirua CC	58 Cluny Rd	Porirua	100	123.7	12.4	66	9.1	1956	1999	43	0.98	2.4	10.0	0.212	9.8	-7%	47	2003	
Porirua CC	Gordon Rd	Porirua	100	122.0	12.2	82	3.6	1956	1999	43	1.20	2.9	9.4	0.088	9.8	-61%	100	2056	
Porirua CC	Mana Esplanade	Porirua	100	122.6	11.7	82	2.9	1966	1999	33	1.20	2.9	8.8	0.088	7.5	-61%	100	2066	
Porirua CC	Moana Rd	Hongoeka Bay	100	124.9	12.4	77	4.8	1956	1999	43	1.13	2.7	9.7	0.112	9.8	-51%	86	2042	
Porirua CC	Passive Grove	Porirua	100	122.8	12.3	82	5.4	1970	1999	29	1.20	2.9	9.4	0.186	6.6	-18%	51	2021	
Porirua CC	SH58 (Paremata Bridge)	Porirua	100	123.1	12.1	87	6.1	1956	1999	43	1.28	3.1	9.0	0.142	9.8	-37%	64	2020	
Porirua CC	South Beach Rd	Porirua	100	122.7	11.5	82	4.3	1956	1999	43	1.20	2.9	8.6	0.099	9.8	-56%	87	2043	
Porirua CC	Terrace Rd	Porirua	100	124.5	13.2	82	3.9	1959	1999	40	1.20	2.9	10.3	0.098	9.1	57%	100	2059	
Porirua CC	Trevor Tce	Paemata	100	124.1	12.4	82	6.4	1956	1999	43	1.20	2.9	9.5	0.149	9.8	-34%	64	2020	
Porirua CC	Whanake	Porirua	100	124.4	13.7	82	5.3	1959	1999	40	1.20	2.9	10.8	0.133	9.1	-42%	81	2040	
Porirua CC	4 Bedford St	Porirua	150	180.0	12.6	92	6.7	1961	1999	38	1.35	4.7	7.9	0.176	8.6	-22%	45	2006	
Porirua CC	Windley Ave	Porirua	150	182.5	21.2	82	6.2	1954	1999	45	1.20	4.3	16.9	0.138	10.2	-39%	100	2054	
Rotorua DC	Tyon Street	Central	100	127.1	17.9	62	6.4	1930	1999	69	0.91	2.3	15.6	0.083	15.7	-59%	100	2030	
Rotorua DC	Pukiaua St	Central	100	127.2	17.7	81	7.8	1955	1999	44	1.19	3.0	14.7	0.177	10.0	-22%	83	2038	
Rotorua DC	11 Dawson Drive	Nongolotia	100	125.6	17.5	83	8.3	1975	1999	24	1.22	3.0	14.5	0.348	5.4	53%	42	2017	
Rotorua DC	Cnr Bedwardine & Beaumonts Rd	Nongolotia	100	126.8	17.0	88	7.8	1954	1999	45	1.29	3.0	13.8	0.173	10.2	-24%	80	2034	
Rotorua DC	11 Hamora Street	Eastern	100	123.3	13.1	75	6.2	1970	1999	29	1.10	2.7	10.5	0.213	6.6	-6%	49	2019	
Rotorua DC	30 Rangitini Street	Nongolotia	100	124.2	17.1	86	8.4	1954	1999	45	1.26	3.1	14.1	0.187	10.2	-18%	75	2029	
Rotorua DC	Cnr Farnsworth & Robinson Ave	Eastern	100	122.2	12.4	104	11.6	1963	1999	36	1.53	3.6	8.7	0.322	8.2	42%	27	1990	
Rotorua DC	36 Rangitini Street	Nongolotia	100	124.3	17.2	86	8.6	1954	1999	36	1.26	3.1	14.1	0.191	10.2	-16%	74	2028	
Rotorua DC	Pukerangi Road	Central	200	234.4	19.5	55	7.6	1975	2000	25	0.81	3.7	15.8	0.304	5.7	34%	52	2027	
Rotorua DC	6 Melrose Ave	Eastern	100	123.9	13.6	96	7.0	1963	2000	37	1.41	3.4	13.2	0.189	8.4	-17%	54	2017	
Salwyn DC	Springton Pipeline	Springton	100	125.0	14.0	24	7.5	1968	2000	32	0.35	0.9	10.1	0.234	7.3	3%	56	2024	
Taupo DC	Puanga Street	Taupo	100	123.4	10.6	70	11.0	1960	2000	40	1.03	2.5	8.1	0.275	9.1	21%	30	1990	
Taupo DC	Mangakino	Mangakino	225	262.0	28.2	24	10.7	1947	2000	53	0.35	1.8	26.4	0.202	12.0	-11%	100	2047	



Input from National Data Base										Calculations Based on Sample Data				Deterioration Model Output			Lifetime Prediction Model Output	
Local Authority	Location Description	City/Town	Pipe DN (mm)	Mean Pipe OD (mm)	Min. Pipe Wall Thickness (mm)	Working Pressure (m)	Total Def'n (mm)	Year of Installation	Year of Appraisal	Sample Age (years)	Working Pressure + Surge (MPa)	Minimum Undeteriorated Wt before failure (mm)	Total Def'n Causing Failure (mm)	Sample Def'n Rate (mm/year)	Modelled Def'n (mm)	Comparison with National Average	Estimated Pipe Life (years)	Estimated Year of First Def'n Failure
Timaru DC	Avenue Rd	Timaru	50	70.3	9.9	52	6.0	1962	1999	37	0.76	1.1	8.8	0.162	8.4	-29%	54	2016
Timaru DC	Evans St	Timaru	50	72.1	10.8	65	8.5	1965	1999	34	0.95	1.4	9.4	0.250	7.7	10%	38	2003
Timaru DC	Miro St	Timaru	50	72.8	11.3	55	10.0	1985	1999	14	0.81	1.2	10.1	0.714	3.2	215%	14	1999
Timaru DC	North St	Timaru	50	73.7	11.6	53	7.0	1950	1999	49	0.78	1.1	10.5	0.143	11.1	-37%	73	2023
Timaru DC	Sophia St (Outside Timaru Mfrs)	Timaru	50	70.8	10.1	70	9.0	1967	1999	32	1.03	1.4	8.6	0.281	7.3	24%	31	1999
Timaru DC	Andrew St	Timaru	100	127.7	18.2	55	11.5	1952	1999	47	0.81	2.0	16.2	0.245	10.7	8%	66	2018
Timaru DC	Clyde Carr Cresc. (23 Luxmoore Rd)	Timaru	100	124.0	13.1	70	9.5	1967	1999	32	1.03	2.5	10.6	0.297	7.3	31%	36	2003
Timaru DC	Flemington St	Timaru	100	124.0	14.0	67	7.4	1975	1999	24	0.98	2.4	11.6	0.313	5.4	38%	37	2012
Timaru DC	George St	Geraldine	100	119.1	14.1	50	12.5	1956	1999	43	0.73	1.7	12.4	0.291	9.8	28%	43	1999
Timaru DC	Goulds Rd (BLUE)	Timaru	100	127.8	13.8	60	9.0	1957	1999	42	0.88	2.2	11.6	0.214	9.5	-6%	54	2011
Timaru DC	Guise St	Timaru	100	125.8	14.4	50	6.0	1989	1999	10	0.73	1.8	12.6	0.600	2.3	164%	21	2010
Timaru DC	Jure St (Historic 898)	Timaru	100	122.0	11.7	60	11.5	1960	1999	39	0.88	2.1	9.6	0.295	8.8	30%	32	1992
Timaru DC	Morgans Rd, New Life Centre	Timaru	100	124.1	13.1	54	7.5	1980	1999	19	0.79	1.9	11.1	0.395	4.3	74%	28	2008
Timaru DC	Princess St	Timaru	100	124.0	13.0	50	9.0	1966	1999	33	0.73	1.8	11.2	0.273	7.5	20%	41	2007
Timaru DC	Someraset St	Timaru	100	126.5	17.0	60	7.5	1955	1999	44	0.88	2.2	14.8	0.170	10.0	25%	87	2042
Timaru DC	Bridge Street	Geraldine	150	178.0	17.5	59	14.4	1956	1999	43	0.87	3.0	14.5	0.335	9.8	48%	43	1999
Timaru DC	Butler St	Timaru	150	180.0	12.1	65	6.0	1974	1999	25	0.95	3.4	8.7	0.240	5.7	6%	36	2010
Timaru DC	Dee St	Timaru	150	179.0	16.0	58	7.0	1979	1999	20	0.85	3.0	13.0	0.350	4.5	54%	37	2016
Timaru DC	Forest Rd	Geraldine	150	180.0	12.4	50	9.5	1972	1999	27	0.73	2.6	12.5	0.352	6.1	55%	28	2000
Timaru DC	Grey Rd	Timaru	150	179.2	15.1	50	4.0	1983	1999	16	0.73	2.6	12.5	0.250	3.6	10%	50	2033
Timaru DC	Hilton Highway	Timaru	150	178.0	15.7	0	10.0	1966	2000	34	0.00	0.0	15.7	0.294	7.7	30%	53	2019
Timaru DC	King St, Redruth	Timaru	150	178.8	14.3	75	12.0	1960	1999	39	1.10	3.9	10.5	0.308	8.8	36%	34	1999
Timaru DC	Lachlan St	Timaru	150	178.0	15.6	50	8.5	1966	1999	33	0.73	2.6	13.0	0.288	7.5	14%	50	2016
Timaru DC	Flinders St	Timaru	200	236.9	20.2	67	6.5	1980	1999	19	0.98	4.6	15.6	0.342	4.3	51%	46	2026
Timaru DC	Halstead Rd	Pleasant Pt	200	233.5	19.0	50	9.5	1984	1999	35	0.73	3.4	15.6	0.271	7.9	20%	57	2021
Timaru DC	Hilton Highway, Meadows Rd	Timaru	200	234.0	18.8	80	11.5	1966	1999	33	1.17	5.4	13.4	0.348	7.5	54%	39	2005
Timaru DC	Hilton Highway, Outside NZ Safety Ltd	Timaru	200	234.0	18.8	80	9.0	1966	1999	33	1.17	5.4	13.4	0.273	7.5	20%	49	2015
Timaru DC	Meadows Rd, Westlake Ck, Br	Timaru	200	237.3	19.9	50	7.5	1966	1999	33	1.17	5.4	14.5	0.227	7.5	0%	64	2030
Timaru DC	Richard Pearce Dr	Timaru	200	235.5	19.4	59	12.5	1969	1999	30	0.87	4.0	15.4	0.417	6.8	84%	37	2006
Timaru DC	Old North Rd & Andrew St	Timaru	250	287.8	23.1	45	9.5	1965	1999	34	0.66	3.8	19.3	0.279	7.7	23%	69	2034
Timaru DC	Oran Pipeline (near Res.)	Geraldine	250	292.7	23.9	10	9.5	1975	1999	24	0.15	0.9	23.1	0.396	5.4	74%	58	2033
Timaru DC	Olupua Rd	Timaru	250	288.0	22.0	45	9.5	1966	1999	33	0.66	3.8	18.2	0.288	7.5	27%	63	2029
Timaru DC	Hilton Highway, Washohyke	Timaru	300	349.7	26.4	80	5.0	1973	1999	26	1.17	8.0	18.3	0.192	5.9	-15%	95	2068
Timaru DC	Olupua Rd	Timaru	300	349.3	26.8	45	9.5	1965	1999	34	0.66	4.6	22.2	0.279	7.7	23%	80	2045
Upper Hutt CC	1 Birch Grove	Upper Hutt	100	123.0	13.0	70	7.9	1954	1992	38	1.03	2.5	10.5	0.208	8.6	-8%	51	2005
Upper Hutt CC	1 Whitehall Grove	Upper Hutt	100	124.5	13.5	81	5.0	1967	1992	25	1.19	2.9	10.6	0.200	5.7	-12%	53	2020
Upper Hutt CC	10 Whitehall Grove	Upper Hutt	100	125.7	14.0	81	5.0	1967	1992	25	1.19	2.9	11.1	0.200	5.7	-12%	55	2022
Upper Hutt CC	2 Birch Grove	Upper Hutt	100	121.0	13.0	70	8.5	1954	1993	39	1.03	2.4	10.6	0.218	8.8	-4%	48	2002
Upper Hutt CC	21 Pinehill Crescent	Upper Hutt	100	125.7	17.0	81	6.0	1962	1992	30	1.19	2.9	14.1	0.200	6.8	-12%	70	2032
Upper Hutt CC	Barton Road	Upper Hutt	100	127.7	16.0	70	9.0	1954	1992	38	1.03	2.6	13.4	0.237	8.6	4%	57	2011
Upper Hutt CC	Birch Grove	Upper Hutt	100	121.9	13.0	70	6.7	1954	1992	38	1.03	2.5	10.5	0.176	8.6	-22%	60	2014
Upper Hutt CC	Golders Road	Upper Hutt	100	130.0	16.0	70	12.0	1950	1993	43	1.03	2.6	13.4	0.279	9.8	23%	48	1998
Upper Hutt CC	Jocelyn Cres	Upper Hutt	100	123.0	13.0	60	8.7	1963	1992	39	0.88	2.1	10.9	0.223	8.8	-2%	49	2002
Upper Hutt CC	McMurtre Grove	Upper Hutt	100	127.8	16.2	81	6.5	1962	1992	30	1.19	3.0	15.2	0.217	6.8	-5%	70	2032
Upper Hutt CC	Winchester Avenue	Upper Hutt	100	124.0	13.0	70	5.4	1954	1992	38	1.03	2.5	10.5	0.142	8.6	-37%	74	2028
Upper Hutt CC	105 Pinehaven Road	Upper Hutt	150	179.0	16.0	70	10.5	1953	1992	38	1.03	3.6	12.4	0.289	8.8	19%	46	1999
Upper Hutt CC	11 Maymorn Road	Upper Hutt	150	179.0	12.0	30	2.8	1973	1994	21	0.44	1.6	10.4	0.133	4.8	-1%	78	2051
Upper Hutt CC	35 Maymorn Road	Upper Hutt	150	179.8	16.3	100	7.5	1978	2000	27	1.47	5.1	11.2	0.278	6.1	22%	40	2013
Upper Hutt CC	78 Pinehaven Road	Upper Hutt	150	178.2	16.0	70	10.0	1953	1992	39	1.03	3.6	12.4	0.256	8.8	13%	48	2001
Upper Hutt CC	82 Pinehaven Road	Upper Hutt	150	178.3	16.0	70	5.0	1953	1992	39	1.03	3.6	12.4	0.128	8.8	-43%	97	2050
Upper Hutt CC	82/84 Pinehaven Road	Upper Hutt	150	178.3	16.0	70	5.0	1953	1992	39	1.03	3.6	12.4	0.128	8.8	-43%	97	2050



Local Authority	Location Description	Input from National Data Base										Calculations Based on Sample Data					Deterioration Model Output			Lifetime Prediction Model Output	
		City/Town	Pipe DN (mm)	Mean Pipe OD (mm)	Min. Pipe Wall Thickness (mm)	Working Pressure (m)	Total Def'n (mm)	Year of Installation	Year of Appraisal	Sample Age (years)	Working Pressure + Surge (MPa)	Minimum Undeteriorated Wt before failure (mm)	Total Def'n Causing Failure (mm)	Sample Def'n Rate (mm/year)	Modelled Def'n (mm)	Comparison with National Average	Estimated Pipe Life (years)	Estimated Year of First Def'n Failure			
Upper Hutt CC	Anzac Road	Upper Hutt	150	185.0	20.0	70	10.0	1942	1991	49	1.03	3.7	16.3	0.204	11.1	-10%	80	2022			
Upper Hutt CC	Beth Street	Upper Hutt	150	185.0	16.0	65	9.5	1947	1991	44	0.95	3.5	12.5	0.216	10.0	-5%	58	2005			
Upper Hutt CC	Elmslie Road	Upper Hutt	150	182.0	16.0	70	9.7	1953	1993	44	1.03	3.7	12.3	0.243	9.1	7%	51	2004			
Upper Hutt CC	Maymorn Road - Pig Farm	Upper Hutt	150	179.6	16.8	90	11.5	1973	2000	27	1.32	4.6	12.2	0.426	6.1	88%	29	2002			
Upper Hutt CC	Wynham Road	Upper Hutt	150	178.0	16.0	70	10.3	1953	1994	41	1.03	3.6	12.4	0.251	9.3	11%	49	2002			
Waikato DC	Bailey St	Huntly	100	130.0	18.2	56	3.5	1943	1999	56	0.82	2.1	16.1	0.063	12.7	-72%	100	2043			
Waikato DC	Croft Tce	Huntly	100	122.9	13.5	56	8.0	1980	1999	19	0.82	2.0	11.5	0.421	4.3	86%	27	2007			
Waikato DC	Elroy St	Ngaruawahia	100	122.5	13.3	51	11.5	1973	1999	26	0.75	1.8	11.5	0.442	5.9	95%	26	1999			
Waikato DC	George St	Ngaruawahia	100	124.0	14.0	51	7.0	1973	1999	26	0.75	1.8	12.2	0.269	5.9	19%	45	2018			
Waikato DC	Great South Rd	Ngaruawahia	100	127.3	18.6	51	12.5	1953	1999	46	0.75	1.9	16.7	0.272	10.4	20%	62	2015			
Waikato DC	Great South Rd	Huntly	100	132.5	21.2	56	2.0	1938	1999	61	0.82	2.1	19.1	0.033	13.8	-86%	100	2038			
Waikato DC	Herewini St	Meremere	100	125.5	17.5	51	11.5	1960	1999	39	0.75	1.9	15.6	0.295	8.8	30%	53	2013			
Waikato DC	Kimihia Rd	Huntly	100	125.5	14.0	36	11.5	1964	1999	35	0.53	1.3	12.7	0.329	7.9	45%	39	2003			
Waikato DC	Kohe Kohe St	Meremere	100	123.5	16.8	51	7.0	1960	1999	39	0.75	1.8	15.0	0.179	8.8	-21%	83	2043			
Waikato DC	Nanomeleme St	Meremere	100	123.5	13.4	51	10.0	1960	1999	39	0.75	1.8	11.6	0.256	8.8	13%	45	2005			
Waikato DC	Old Taupiri Rd	Ngaruawahia	100	121.5	12.8	51	12.0	1963	1999	36	0.82	2.0	12.4	0.333	8.2	47%	37	2000			
Waikato DC	Paki St	Huntly	100	124.2	14.1	51	9.5	1964	1999	35	0.75	1.8	10.8	0.271	7.9	20%	40	2004			
Waikato DC	Ouse St	Ngaruawahia	100	124.2	14.1	51	11.0	1973	1999	26	0.75	1.8	12.3	0.423	5.9	86%	29	2002			
Waikato DC	River View Rd	Huntly	100	127.3	19.1	51	8.5	1966	1999	33	0.75	1.9	17.2	0.268	7.5	14%	67	2033			
Waikato DC	Russell Rd	Huntly	100	124.1	16.9	36	9.0	1966	1999	33	0.53	1.3	15.6	0.273	7.5	20%	57	2023			
Waikato DC	Simms St	Ngaruawahia	100	123.5	13.4	51	9.5	1965	1999	34	0.75	1.8	11.6	0.279	7.7	23%	41	2006			
Waikato DC	Tanwharau St	Huntly	100	122.8	13.7	56	8.0	1957	1999	42	0.82	2.0	11.7	0.190	9.5	-16%	61	2018			
Waikato DC	Te Paea Ave (North)	Meremere	100	124.0	13.8	51	11.5	1960	1999	39	0.75	1.8	12.0	0.295	8.8	30%	41	2001			
Waikato DC	Te Paea Ave (South)	Meremere	100	124.5	17.0	51	14.5	1960	1999	39	0.75	1.8	15.2	0.372	8.8	64%	41	2001			
Waikato DC	Thomas St	Ngaruawahia	100	124.5	17.1	51	9.5	1953	1999	46	0.75	1.8	15.3	0.207	10.4	-9%	74	2027			
Waikato DC	Thir St	Huntly	100	128.1	18.1	56	10.5	1944	1999	55	0.82	2.1	16.0	0.191	12.5	-16%	84	2028			
Waikato DC	Waikato Esplanade	Ngaruawahia	100	122.3	13.3	51	9.5	1973	1999	26	0.75	1.8	11.5	0.365	5.9	61%	31	2004			
Waikato DC	Waikato Esplanade	Ngaruawahia	100	124.7	17.3	51	9.0	1955	1999	46	0.75	1.8	15.5	0.196	10.4	-14%	79	2032			
Waikato DC	Waikato Esplanade	Ngaruawahia	100	122.5	13.7	51	9.0	1963	1999	36	0.75	1.8	11.9	0.250	8.2	10%	48	2011			
Waimate DC	Dash Street	Waimate	100	126.0	16.6	73	9.0	1960	1999	39	1.07	2.6	14.0	0.231	8.8	2%	60	2020			
Waimate DC	Goldsmith Street	Waimate	100	123.5	13.0	73	7.2	1968	1999	51	1.07	2.6	10.4	0.232	7.0	2%	45	2013			
Waipa DC	Bond Rd	Te Awamutu	100	124.5	11.6	53	11.5	1950	2000	50	0.78	1.9	9.7	0.230	11.3	1%	42	1992			
Waipa DC	Heselmer St	Te Awamutu	100	123.5	17.0	53	9.0	1950	2000	50	0.78	1.9	15.1	0.180	11.3	-21%	84	2034			
Waipa DC	Park Rd	Te Awamutu	100	121.5	13.8	53	3.5	1993	2000	7	0.78	1.9	11.9	0.500	1.6	120%	24	2017			
Waipa DC	Thorncombe Rd	Te Awamutu	100	125.0	11.0	32	11.0	1960	2000	40	0.47	1.2	16.8	0.275	9.1	21%	61	2021			
Waipa DC	Wardsworth St	Cambridge	100	122.5	13.0	0	8.0	0	2000	2000	0.00	0.0	13.0	0.004	453.8	-98%	100	100			
Waipa DC	Bridgman St	Te Awamutu	150	179.0	21.6	53	9.5	1955	2000	45	0.78	2.7	18.9	0.211	10.2	-7%	85	2044			
Waipa DC	Hamilton Rd	Cambridge	200	233.0	23.8	0	9.5	0	2000	2000	0.00	0.0	23.8	0.005	453.8	-98%	100	100			
Waikare CC	10 Hewitt St	Waikare	50	73.4	11.6	68	5.0	1968	1998	30	1.00	1.4	10.2	0.167	6.8	-27%	61	2029			
Waikare CC	111 Ferry Pde	Waikare	50	71.9	11.3	36	7.0	1985	1998	13	0.53	0.8	10.5	0.538	2.9	137%	19	2004			
Waikare CC	96 Durham Rd	Waikare	50	74.3	11.9	48	8.5	1959	1998	39	0.70	1.0	10.9	0.218	8.8	-4%	50	2009			
Waikare CC	40 Rimutaka St	Waikare	50	69.8	9.3	95	3.0	1963	1998	35	1.39	1.9	7.4	0.086	7.9	-62%	86	2049			
Waikare CC	426 Don Buck Rd	Waikare	50	73.0	11.8	50	7.5	1965	1998	33	0.73	1.1	10.7	0.227	7.5	0%	47	2012			
Waikare CC	5 Brains Rd	Waikare	50	72.0	10.5	51	6.0	1961	1998	37	0.75	1.1	9.7	0.162	8.4	-29%	60	2021			
Waikare CC	51 Cronin Ave	Waikare	50	73.1	11.6	58	4.0	1957	1998	41	0.85	1.2	10.4	0.098	9.3	-57%	100	2057			
Waikare CC	65 Farquhar St	Waikare	50	72.6	12.2	53	6.0	1958	1998	40	0.78	1.1	11.1	0.150	9.1	-34%	74	2032			
Waikare CC	9 Chandler Rd	Waikare	50	70.0	9.8	43	6.0	1966	1998	42	0.63	0.9	8.9	0.143	9.5	-37%	62	2016			
Waikare CC	95 Rattigan Rd	Waikare	50	74.1	12.3	30	3.0	1962	1998	36	0.84	1.2	11.1	0.083	8.2	-63%	100	2062			
Waikare CC	123 Daifodil St	Waikare	100	125.0	14.3	55	4.0	1964	1998	34	0.81	2.0	12.3	0.118	7.7	-48%	100	2064			
Waikare CC	15 Neal Ave	Waikare	100	122.9	16.4	46	8.0	1966	1998	42	0.68	1.6	14.8	0.190	9.5	-16%	77	2033			
Waikare CC	16 Valley Rd	Waikare	100	124.0	13.7	112	4.0	1989	1998	9	1.64	3.9	9.8	0.444	2.0	96%	22	2011			



Input from National Data Base											Calculations Based on Sample Data				Deterioration Model Output			Lifetime Prediction Model Output	
Local Authority	Location Description	City/Town	Pipe DN (mm)	Mean Pipe OD (mm)	Min. Pipe Wall Thickness (mm)	Working Pressure (m)	Total Det'n (mm)	Year of Installation	Year of Appraisal	Sample Age (years)	Working Pressure + Surge (MPa)	Minimum Undeteriorated Wt before failure (mm)	Total Det'n Causing Failure (mm)	Sample Det'n Rate (mm/year)	Modelled Det'n (mm)	Comparison with National Average	Estimated Pipe Life (years)	Estimated Year of First Det'n Failure	
Waitakere CC	2 Covill Ave	Waitakere	100	128.5	17.8	49	4.0	1950	1998	48	0.72	1.8	16.0	0.083	10.9	-63%	100	2050	
Waitakere CC	226 Sadley Rd	Waitakere	100	125.4	14.0	27	5.0	1953	1998	39	0.40	1.0	13.0	0.128	8.8	-53%	100	2055	
Waitakere CC	23 Kokiri St	Waitakere	100	123.5	13.6	51	4.0	1953	1998	45	0.75	1.8	11.8	0.089	10.2	-61%	100	2053	
Waitakere CC	24 Terra Nova Pl	Waitakere	100	123.7	13.2	41	4.0	1974	1998	24	0.60	1.5	11.7	0.167	5.4	-27%	70	2044	
Waitakere CC	28 Eastglen Rd	Waitakere	100	125.7	14.7	55	6.0	1966	1998	32	0.81	2.0	12.7	0.188	7.3	-17%	68	2034	
Waitakere CC	3 Nicholias Ave	Waitakere	100	124.2	13.6	95	5.0	1987	1998	31	1.39	3.4	10.2	0.161	7.0	-29%	63	2030	
Waitakere CC	51 Onedin St	Waitakere	100	121.8	13.6	84	7.5	1984	1998	14	1.23	2.9	10.7	0.536	3.2	136%	20	2004	
Waitakere CC	55 Donovin Dr	Waitakere	100	121.7	13.5	80	4.0	1976	1998	22	1.17	2.8	10.7	0.182	5.0	-20%	59	2035	
Waitakere CC	95 Chilcott Ave	Waitakere	100	122.7	13.3	69	6.0	1989	1998	29	1.01	2.4	10.9	0.207	6.6	-9%	53	2022	
Waitakere CC	65 Tanekaha Rd	Waitakere	100	126.9	12.7	75	10.0	1989	1998	9	1.10	2.7	10.0	1.111	2.0	390%	9	1998	
Waitakere CC	Frank Evans Pl	Waitakere	100	123.8	13.9	56	4.0	1982	1998	16	0.82	2.0	11.9	0.250	3.6	10%	48	2030	
Waitakere CC	13 Lagoona Way	Waitakere	150	179.0	16.4	79	4.0	1986	1998	12	1.16	4.1	12.3	0.333	2.7	47%	37	2023	
Waitakere CC	14 Warwick St	Waitakere	150	127.9	19.4	40	7.0	1971	1998	27	0.59	1.5	17.9	0.259	6.1	14%	69	2040	
Waitakere CC	33 Luanda Dr	Waitakere	150	179.0	16.7	54	5.0	1975	1998	23	0.79	2.8	13.9	0.217	5.2	-4%	64	2039	



Summary of Observed Minimum Pipe Wall Thickness

Local Authority	Location Description	City/Town	Pipe DN	Minimum Observed Wt (mm)
Waitakere CC	40 Rimutaka St	Waitakere	50	9.3
Waitakere CC	9 Grainger Rd	Waitakere	50	9.8
Timaru DC	Avenue Rd	Timaru	50	9.86
North Shore CC	Hillside Rd	Glenfield	50	9.92
Timaru DC	Sophia St (outside Timaru Mtrs)	Timaru	50	10.06
Timaru DC	Evans St	Timaru	50	10.76
Waitakere CC	5 Brains Rd	Waitakere	50	10.8
North Shore CC	Sudan Ave	Milford	50	10.81
North Shore CC	Waiau St	Torbay	50	10.81
North Shore CC	Halberg St	Glenfield	50	10.95
North Shore CC	Hauraki Cres	Glenfield	50	10.99
North Shore CC	Stanaway St	Glenfield	50	11.16
North Shore CC	Halberg St	Glenfield	50	11.17
Waitakere CC	111 Ferry Pde	Waitakere	50	11.3
Timaru DC	Miro St	Timaru	50	11.28
Porirua CC	8 Leicester St	Porirua	50	11.3
Porirua CC	34 Champion St	Porirua	50	11.4
Porirua CC	39 Levant Cres	Porirua	50	11.5
North Shore CC	Waitemata Rd	Takapuna	50	11.53
North Shore CC	Nea Rd	Glenfield	50	11.58
Timaru DC	North St	Timaru	50	11.6
Waitakere CC	10 Hewett St	Waitakere	50	11.6
Waitakere CC	51 Cronin Ave	Waitakere	50	11.6
Waitakere CC	426 Don Buck Rd	Waitakere	50	11.8
Waitakere CC	36 Durham Rd	Waitakere	50	11.9
North Shore CC	Camelot Pl	Glenfield	50	12.11
Waitakere CC	65 Farquhar St	Waitakere	50	12.2
Waitakere CC	95 Rathgar Rd	Waitakere	50	12.3
Porirua CC	Cnr. Hazzard Gr and Calliope St.	Porirua	50	12.4
Porirua CC	Mungavin Avenue	Porirua	50	12.48
Porirua CC	123 Champion St	Porirua	50	12.7
Porirua CC	8 Hazzard Gr	Porirua	50	12.7
North Shore CC	Weldene Ave	Glenfield	50	12.97
North Shore CC	Weldene Ave	Glenfield	50	13.12
North Shore CC	Weldene Ave	Glenfield	50	13.22
Taupo DC	Puanga Street	Tokaanu	100	10.6
Christchurch CC	Brynley Street	Christchurch	100	11.0
Invercargill CC	Jack Street	Invercargill	100	11
Christchurch CC	Tyrone Street	Christchurch	100	11.1
M o E	Sample 2 (Main Driveway)	Casebrook Int. Sch.	100	11.1
Ashburton DC	Trevors Rd	Ashburton	100	11.2
M o E	Sample 1 (Fire Hydrant)	Casebrook Int. Sch.	100	11.4
Porirua CC	South Beach Rd	Porirua	100	11.48
Ashburton DC	Thompson St	Ashburton	100	11.5
NZ Army	6 Takrouna	Linton	100	11.58
Waipa DC	Bond Rd	Te Awamutu	100	11.6



Summary of Observed Minimum Pipe Wall Thickness

Local Authority	Location Description	City/Town	Pipe DN	Minimum Observed Wt (mm)
Timaru DC	June St (Historic 8/98)	Timaru	100	11.68
Porirua CC	Mana Esplanade	Porirua	100	11.7
Christchurch CC	Wai-iti Street	Christchurch	100	11.8
Porirua CC	SH58 (Paremata Bridge)	Porirua	100	12.1
Porirua CC	19-21 Cluny Rd	Porirua	100	12.2
Porirua CC	Gordon Rd	Porirua	100	12.24
Porirua CC	Passive Grove	Porirua	100	12.3
Porirua CC	58 Cluny Rd	Porirua	100	12.4
Porirua CC	Moana Rd	Hongoeka Bay	100	12.4
Porirua CC	Trevor Tce	Paremata	100	12.4
Waitakere CC	65 Tanekaha Rd	Waitakere	100	12.7
Waikato DC	Paki St	Huntly	100	12.8
Gore DC	Otama Water Scheme	Gore	100	12.9
Invercargill CC	Dome Street	Invercargill	100	12.9
Christchurch CC	Straven Road	Christchurch	100	13.0
Upper Hutt CC	1 Birch Grove	Upper Hutt	100	13.0
Upper Hutt CC	2 Birch Grove	Upper Hutt	100	13.0
Upper Hutt CC	Birch Grove	Upper Hutt	100	13.0
Upper Hutt CC	Jocelyn Cres	Upper Hutt	100	13.0
Upper Hutt CC	Winchester Avenue	Upper Hutt	100	13.0
Waimate DC	Goldsmith Street	Waimate	100	13.0
Waipa DC	Wordsworth St	Cambridge	100	13.0
Timaru DC	Princes St	Temuka	100	13.04
Timaru DC	Clyde Carr Cresc. (23 Luxmoore Rd)	Timaru	100	13.06
Christchurch CC	Poynder Ave	Christchurch	100	13.1
Timaru DC	Morgans Rd, New Life Centre	Timaru	100	13.08
Porirua CC	Terrace Rd	Porirua	100	13.2
Waitakere CC	24 Terra Nova Pl	Waitakere	100	13.2
Invercargill CC	Helmsdale Street	Invercargill	100	13.3
Waikato DC	Ellery St	Ngaruawahia	100	13.3
Waikato DC	Waikato Esplanade	Ngaruawahia	100	13.3
Waitakere CC	59 Chilcott Ave	Waitakere	100	13.3
North Shore CC	Unknown	Glenfield	100	13.37
Christchurch CC	Tui Street	Christchurch	100	13.4
Waikato DC	Simms St	Ngaruawahia	100	13.4
Waikato DC	Naho/Meremere Sts	Meremere	100	13.4
Upper Hutt CC	1 Whitehall Grove	Upper Hutt	100	13.5
Waikato DC	Croft Tce	Huntly	100	13.5
Waitakere CC	55 Donovan Dr	Waitakere	100	13.5
North Shore CC	Garner St	Glenfield	100	13.59
Waitakere CC	23 Kokiri St	Waitakere	100	13.6
Waitakere CC	3 Nicholas Ave	Waitakere	100	13.6
Waitakere CC	51 Onedin St	Waitakere	100	13.6
North Shore CC	Theban Pl	Glenfield	100	13.64
North Shore CC	Tesla Pl	Glenfield	100	13.68



Summary of Observed Minimum Pipe Wall Thickness

Local Authority	Location Description	City/Town	Pipe DN	Minimum Observed Wt (mm)
Porirua CC	Whanake	Porirua	100	13.7
Waikato DC	Taniwharau St	Huntly	100	13.7
Waikato DC	Waipa Esplanade	Ngaruawahia	100	13.7
Waitakere CC	16 Valley Rd	Waitakere	100	13.7
North Shore CC	Merida Pl	Glenfield	100	13.73
North Shore CC	Hellyers Rd	Glenfield	100	13.75
Waikato DC	Te Puea Ave (North)	Meremere	100	13.8
Timaru DC	Goulds Rd (BLUE)	Timaru	100	13.8
Waipa DC	Park Rd	Te Awamutu	100	13.8
North Shore CC	Felicity Pl	Glenfield	100	13.84
North Shore CC	Randall Pl	Birkdale	100	13.85
North Shore CC	Taurus Cres	Birkdale	100	13.87
North Shore CC	Mayall Ave	Glenfield	100	13.88
Waitakere CC	Frank Evans Pl	Waitakere	100	13.9
North Shore CC	Laser Pl	Glenfield	100	13.98
Selwyn DC	Springston Pipeline	Springston	100	14
Timaru DC	Flemington St	Timaru	100	14
Upper Hutt CC	10 Whitehall Grove	Upper Hutt	100	14.0
Waikato DC	George St	Ngaruawahia	100	14.0
Waikato DC	Kimihia Rd	Huntly	100	14.0
Waitakere CC	226 Gadley Rd	Waitakere	100	14.0
North Shore CC	Standish Pl	Glenfield	100	14.1
Timaru DC	George St	Geraldine	100	14.1
Waikato DC	Queen St	Ngaruawahia	100	14.1
Waikato DC	Old Taupiri Rd	Ngaruawahia	100	14.2
Waitakere CC	123 Daffodil St	Waitakere	100	14.3
North Shore CC	Tacitus Pl	Glenfield	100	14.42
Timaru DC	Guise St	Temuka	100	14.42
North Shore CC	Orton St	Glenfield	100	14.55
Christchurch CC	Ocean View Terrace	Christchurch	100	14.7
Waitakere CC	28 Eastglen Rd	Waitakere	100	14.7
Far North DC	140 Commerce St	Kaitia	100	15.9
Upper Hutt CC	Barton Road	Upper Hutt	100	16.0
Upper Hutt CC	Golders Road	Upper Hutt	100	16.0
Invercargill CC	Miller Street	Invercargill	100	16.3
Waitakere CC	15 Neal Ave	Waitakere	100	16.4
NZ Army	7 Whites Rd	Burnham	100	16.6
Waimate DC	Dash Street	Waimate	100	16.6
Waikato DC	Kohe Kohe St	Meremere	100	16.8
Carterton DC	Carterton	Carterton	100	16.9
Waikato DC	Russell Rd	Huntly	100	16.9
Christchurch CC	Hooker Avenue	Christchurch	100	17.0
Timaru DC	Somerset St	Timaru	100	17
Upper Hutt CC	21 Pinehill Crescent	Upper Hutt	100	17.0
Waikato DC	Te Puea Ave (South)	Meremere	100	17.0



Summary of Observed Minimum Pipe Wall Thickness

Local Authority	Location Description	City/Town	Pipe DN	Minimum Observed Wt (mm)
Waipa DC	Haselmere St	Te Awamutu	100	17.0
Far North DC	194 Commerce St	Kaitaia	100	17.1
Porirua CC	17 Yorke Pl	Porirua	100	17.1
Waikato DC	Thomas St	Ngaruawahia	100	17.1
Far North DC	Puckey Ave (Int. Taafe St)	Kaitaia	100	17.3
Waikato DC	Waingaro Rd	Ngaruawahia	100	17.3
NZ Army	Puttick Road	Linton	100	17.4
Christchurch CC	Euston Street	Christchurch	100	17.5
Waikato DC	Herewhini St	Meremere	100	17.5
Christchurch CC	Matai Street West	Christchurch	100	17.6
Far North DC	Farrimond St	Kaitaia	100	17.6
Christchurch CC	Ayr Street	Christchurch	100	17.7
Christchurch CC	Hood Street	Christchurch	100	17.7
Waitakere CC	2 Covil Ave	Waitakere	100	17.8
Christchurch CC	Nelson Street	Christchurch	100	18.0
Invercargill CC	Islington Street	Invercargill	100	18
NZ Army	Moa St line	Burnham	100	18
Waipa DC	Thornecombe Rd	Te Awamutu	100	18.0
Christchurch CC	Kibblewhite Street	Christchurch	100	18.0
Christchurch CC	Knowles Street	Christchurch	100	18.1
Waikato DC	Tither St	Huntly	100	18.1
Christchurch CC	Hansons Lane	Christchurch	100	18.2
Upper Hutt CC	McMurtie Grove	Upper Hutt	100	18.2
Waikato DC	Bailey St	Huntly	100	18.2
Timaru DC	Andrew St	Timaru	100	18.22
Ashburton DC	John St	Ashburton	100	18.3
Waikato DC	Great South Rd	Ngaruawahia	100	18.6
Waikato DC	River View Rd	Huntly	100	19.1
Waikato DC	Great South Rd	Huntly	100	21.2
Christchurch CC	Gilberthorpes Road	Christchurch	150	11.6
Upper Hutt CC	11 Maymorn Road	Upper Hutt	150	12.0
Timaru DC	Butler St	Timaru	150	12.06
Ashburton DC	Bryant St	Ashburton	150	12.2
Ashburton DC	Farm Rd	Ashburton	150	12.3
Timaru DC	Forest Rd	Geraldine	150	12.36
Christchurch CC	Clyde Road	Christchurch	150	12.5
North Shore CC	Santiago Cres	Glenfield	150	12.55
Porirua CC	4 Bedford St	Porirua	150	12.6
Timaru DC	King St, Redruth	Timaru	150	14.32
Timaru DC	Grey Rd	Timaru	150	15.14
Christchurch CC	Hardwicke Street	Christchurch	150	15.4
Timaru DC	Lachlan St	Temuka	150	15.58
Timaru DC	Hilton Highway	Timaru	150	15.7
North Shore CC	Trais Rd	Glenfield	150	15.82
North Shore CC	Pemberton Ave	Glenfield	150	15.86



Summary of Observed Minimum Pipe Wall Thickness

Local Authority	Location Description	City/Town	Pipe DN	Minimum Observed Wt (mm)
Far North DC	195 Commerce St	Kaitaia	150	15.9
Timaru DC	Dee St	Timaru	150	16
Upper Hutt CC	105 Pinehaven Road	Upper Hutt	150	16.0
Upper Hutt CC	78 Pinehaven Road	Upper Hutt	150	16.0
Upper Hutt CC	82 Pinehaven Road	Upper Hutt	150	16.0
Upper Hutt CC	82/84 Pinehaven Road	Upper Hutt	150	16.0
Upper Hutt CC	Beth Street	Upper Hutt	150	16.0
Upper Hutt CC	Elmslie Road	Upper Hutt	150	16.0
Upper Hutt CC	Wyndham Road	Upper Hutt	150	16.0
North Shore CC	Trais Rd	Glenfield	150	16.19
Christchurch CC	Waimari Road	Christchurch	150	16.2
NZ Army	B27 Ditmers Road	Linton	150	16.3
Upper Hutt CC	35 Maymorn Road	Upper Hutt	150	16.3
Waitakere CC	13 Lagoon Way	Waitakere	150	16.4
NZ Army	Fosters Raod	Linton	150	16.48
Christchurch CC	Lydia Street	Christchurch	150	16.5
North Shore CC	Athena Dr	Glenfield	150	16.7
Waitakere CC	33 Luanda Dr	Waitakere	150	16.7
Christchurch CC	Wiremu Street	Christchurch	150	16.7
Upper Hutt CC	Maymorn Road - Pig Farm	Upper Hutt	150	16.8
North Shore CC	Bush Rd	Albany	150	17.43
Invercargill CC	Mersey Street	Invercargill	150	17.5
Timaru DC	Bridge Street	Geraldine	150	17.5
NZ Army	12 Kippenberger	Linton	150	17.58
Christchurch CC	Lowe Street	Christchurch	150	17.7
North Shore CC	Ashfield Rd	Glenfield	150	17.7
North Shore CC	Athena Dr	Glenfield	150	18.86
North Shore CC	Ashley Ave	Torbay	150	18.91
Waitakere CC	14 Warwick St	Waitakere	150	19.4
Upper Hutt CC	Anzac Road	Upper Hutt	150	20.0
Christchurch CC	Matipo Street	Christchurch	150	20.8
Porirua CC	Windley Ave	Porirua	150	21.2
Far North DC	44 Commerce St	Kaitaia	150	21.3
Waipa DC	Bridgman St	Te Awamutu	150	21.6
NZ Army	X37 Delivery line to tower	Burnham	150	21.9
Christchurch CC	Main South Road Templeton P Station	Christchurch	200	15.4
Christchurch CC	Belfast Road	Christchurch	200	15.6
Ashburton DC	McNally St	Ashburton	200	15.9
Christchurch CC	Fendalton Road	Christchurch	200	16.5
Christchurch CC	Cranford Street	Christchurch	200	18.7
Timaru DC	Hilton Highway, Meadows Rd	Timaru	200	18.8
Timaru DC	Hilton Highway, Outside NZ Safety Ltd	Timaru	200	18.8
Timaru DC	Halstead Rd	Pleasant Pt	200	19.0
Christchurch CC	Station Road	Christchurch	200	19.38
Timaru DC	Richard Pearce Dr	Temuka	200	19.4



Summary of Observed Minimum Pipe Wall Thickness

Local Authority	Location Description	City/Town	Pipe DN	Minimum Observed Wt (mm)
Christchurch CC	Holliss Avenue	Christchurch	200	19.74
Christchurch CC	Byron Street	Christchurch	200	19.9
Timaru DC	Meadows Rd Washdyke Ck Br	Timaru	200	19.9
Christchurch CC	Springs Road	Christchurch	200	20.02
NZ Army	E17 Rowlings Road	Linton	200	20.02
Christchurch CC	Queenspark Drive	Christchurch	200	20.12
Timaru DC	Flinders St	Timaru	200	20.18
Waipa DC	Hamilton Rd	Cambridge	200	23.8
Taupo DC	Mangakino	Mangakino	225	28.2
Christchurch CC	Emmett Street	Christchurch	225	28.9
Timaru DC	Otipua Rd	Timaru	250	22.0
Timaru DC	Old North Rd & Andrew St	Timaru	250	23.1
Timaru DC	Orari Pipeline (near Res.)	Geraldine	250	23.9
Christchurch CC	Watts Road	Christchurch	300	18.18
Christchurch CC	Darrock street	Christchurch	300	18.62
Christchurch CC	Waiwetū Street	Christchurch	300	19
Hauraki DC	Paeroa	Paeroa	300	23.2
Hauraki DC	Paeroa	Paeroa	300	24
Hauraki DC	Paeroa	Paeroa	300	24.6
Christchurch CC	Hills Road	Christchurch	300	25.1
Timaru DC	Hilton Highway, Washdyke	Timaru	300	26.4
Timaru DC	Otipua Rd	Timaru	300	26.8
Christchurch CC	St Asaph Street	Christchurch	300	27.16
Christchurch CC	Aynsley Terrace	Christchurch	300	27.2



Lifetime Prediction Chart Calculations (50mm)

Pipe Class	Average Det'n Rate (mm/yr)	Average Wt (mm)	Standard Min Wt (mm)	Standard OD (mm)
50mm E/F	0.2269	0.0	8.4	51

Working Pressure (m)	Working Pressure + Surge (MPa)	Theoretical Min Wt (mm)	Det'n Causing Failure (mm)	Predicted Lifetime
			50mm E/F	50mm E/F
10	0.15	0.15	9.25	41
20	0.29	0.30	9.10	40
30	0.44	0.45	8.95	39
40	0.59	0.59	8.81	39
50	0.73	0.74	8.66	38
60	0.88	0.88	8.52	38
70	1.03	1.03	8.37	37
80	1.17	1.17	8.23	36
90	1.32	1.31	8.09	36
100	1.47	1.45	7.95	35
110	1.62	1.60	7.80	34
120	1.76	1.74	7.66	34
130	1.91	1.88	7.52	33
140	2.06	2.01	7.39	33
150	2.20	2.15	7.25	32
160	2.35	2.29	7.11	31
170	2.50	2.43	6.97	31
180	2.64	2.56	6.84	30
190	2.79	2.70	6.70	30
200	2.94	2.83	6.57	29
210	3.08	2.96	6.44	28
220	3.23	3.10	6.30	28
230	3.38	3.23	6.17	27



Lifetime Prediction Chart Showing Predicted Years to Failure
(based on standard minimum wall thickness + 1mm and average deterioration rate)

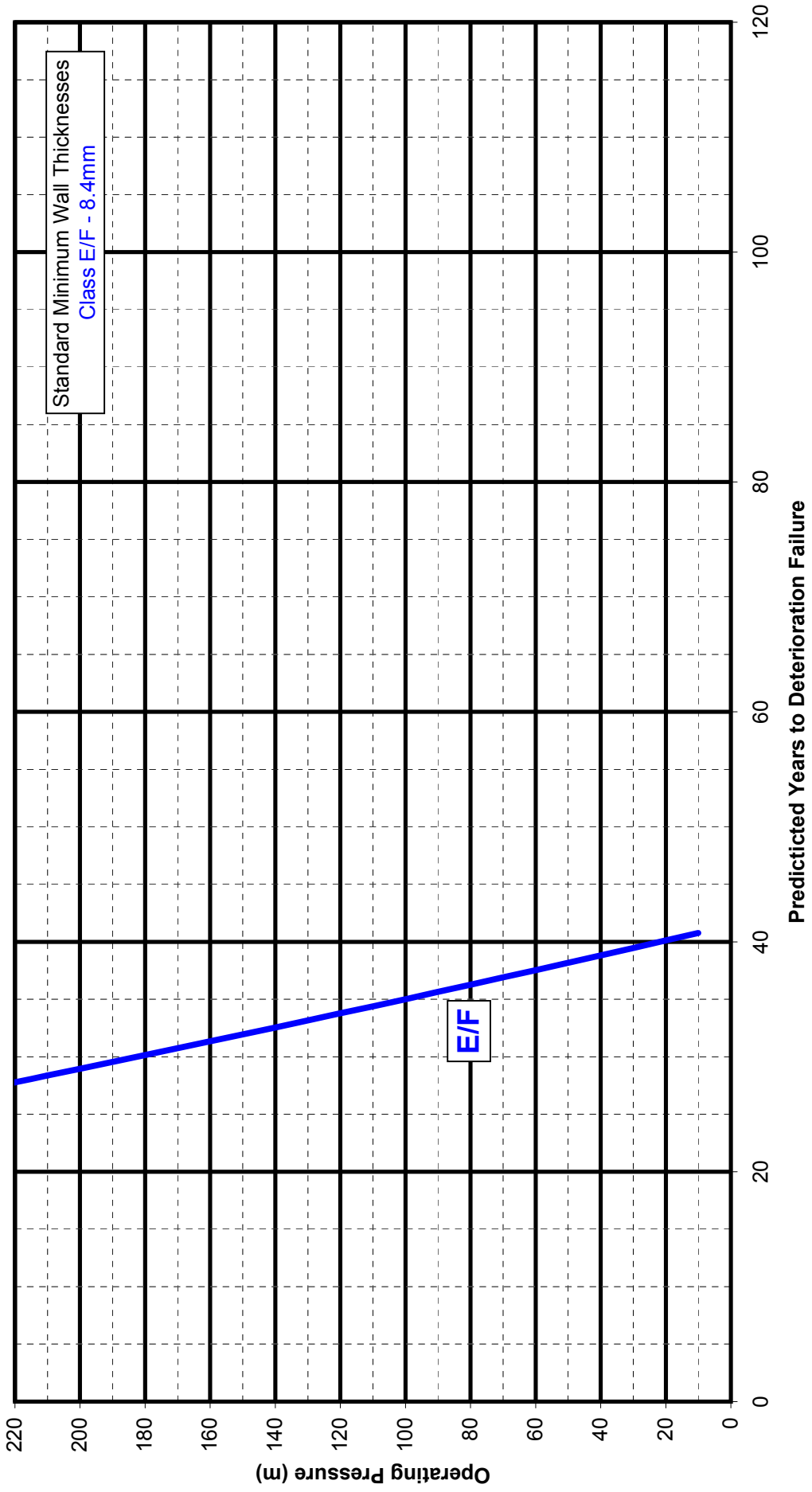



Variable Detn Chart Calculations (50mm)

Pipe Class	Average WT (mm)	Standard Min Wt (mm)	Standard OD (mm)	Rates of Deterioration (mm/yr)										
50mm E/F	0.0	8.4	51	<table style="width: 100%; border-collapse: collapse;"> <tr> <td style="width: 50%;">85% (Upper)</td> <td style="text-align: center;">0.4000</td> </tr> <tr> <td>50% (Upper)</td> <td style="text-align: center;">0.2857</td> </tr> <tr> <td style="text-align: center;">Average Rate</td> <td style="text-align: center;">0.2269</td> </tr> <tr> <td>50% (Lower)</td> <td style="text-align: center;">0.1750</td> </tr> <tr> <td>85% (Lower)</td> <td style="text-align: center;">0.1222</td> </tr> </table>	85% (Upper)	0.4000	50% (Upper)	0.2857	Average Rate	0.2269	50% (Lower)	0.1750	85% (Lower)	0.1222
85% (Upper)	0.4000													
50% (Upper)	0.2857													
Average Rate	0.2269													
50% (Lower)	0.1750													
85% (Lower)	0.1222													
The Standard Minimum Wall Thickness + 1mm Will be Used for Lifetime Calculations														

Working Pressure (m)	Working Pressure + Surge (MPa)	Theoretical Min Wt (mm)	Det'n Causing Failure (mm)	Predicted Lifetimes				
				85% (Upper)	50% (Upper)	Average Rate	50% (Lower)	85% (Lower)
10	0.15	0.15	9.25	23	32	41	53	76
20	0.29	0.30	9.10	23	32	40	52	74
30	0.44	0.45	8.95	22	31	39	51	73
40	0.59	0.59	8.81	22	31	39	50	72
50	0.73	0.74	8.66	22	30	38	49	71
60	0.88	0.88	8.52	21	30	38	49	70
70	1.03	1.03	8.37	21	29	37	48	69
80	1.17	1.17	8.23	21	29	36	47	67
90	1.32	1.31	8.09	20	28	36	46	66
100	1.47	1.45	7.95	20	28	35	45	65
110	1.62	1.60	7.80	20	27	34	45	64
120	1.74	1.74	7.66	19	27	34	44	63
130	1.91	1.88	7.52	19	26	33	43	62
140	2.06	2.01	7.39	18	26	33	42	60
150	2.20	2.15	7.25	18	25	32	41	59
160	2.35	2.29	7.11	18	25	31	41	58
170	2.50	2.43	6.97	17	24	31	40	57
180	2.64	2.56	6.84	17	24	30	39	56
190	2.79	2.70	6.70	17	23	30	38	55
200	2.94	2.83	6.57	16	23	29	38	54
210	3.08	2.96	6.44	16	23	28	37	53
220	3.23	3.10	6.30	16	22	28	36	52
230	3.38	3.23	6.17	15	22	27	35	51



Lifetime Prediction Chart Showing Range of Predicted Years to Failure
(based on standard minimum wall thickness + 1 mm)

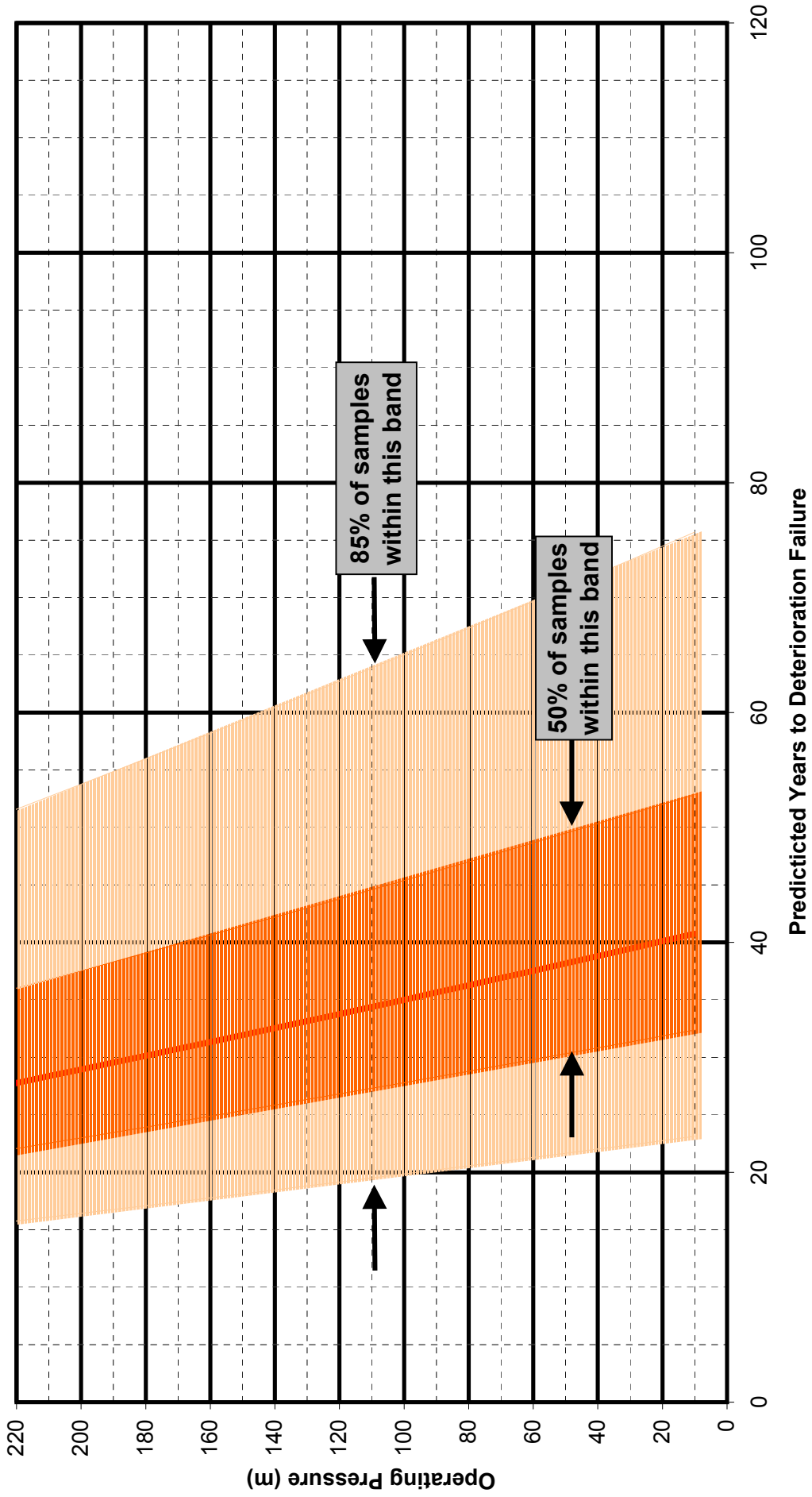



Lifetime Prediction Chart Calculations (80mm)

Pipe Class	Average Det'n Rate (mm/yr)	Average Wt (mm)	Standard Min Wt (mm)	Standard OD (mm)
80mm A/B	0.0	0.0	9.4	96
80mm C/D	0.0	0.0	10.2	96
80mm E/F	0.0	0.0	13	96

Working Pressure (m)	Working Pressure + Surge (MPa)	Theoretical Min Wt (mm)	80mm A/B		80mm C/D		80mm E/F	
			Det'n Causing Failure (mm)	Predicted Lifetime	Det'n Causing Failure (mm)	Predicted Lifetime	Det'n Causing Failure (mm)	Predicted Lifetime
10	0.15	0.28	10.12	45	10.92	48	13.72	60
20	0.29	0.56	9.84	43	10.64	47	13.44	59
30	0.44	0.84	9.56	42	10.36	46	13.16	58
40	0.59	1.11	9.29	41	10.09	44	12.89	57
50	0.73	1.39	9.01	40	9.81	43	12.61	56
60	0.88	1.66	8.74	39	9.54	42	12.34	54
70	1.03	1.93	8.47	37	9.27	41	12.07	53
80	1.17	2.20	8.20	36	9.00	40	11.80	52
90	1.32	2.47	7.93	35	8.73	38	11.53	51
100	1.47	2.74	7.66	34	8.46	37	11.26	50
110	1.62	3.00	7.40	33	8.20	36	11.00	48
120	1.76	3.27	7.13	31	7.93	35	10.73	47
130	1.91	3.53	6.87	30	7.67	34	10.47	46
140	2.06	3.79	6.61	29	7.41	33	10.21	45
150	2.20	4.05	6.35	28	7.15	32	9.95	44
160	2.35	4.31			6.89	30	9.69	43
170	2.50	4.56			6.64	29	9.44	42
180	2.64	4.82			6.38	28	9.18	40
190	2.79	5.07			6.13	27	8.93	39
200	2.94	5.33			5.87	26	8.67	38
210	3.08	5.58			5.62	25	8.42	37
220	3.23	5.83			5.37	24	8.17	36
230	3.38	6.07			5.13	23	7.93	35



Lifetime Prediction Chart Showing Predicted Years to Failure
(based on standard minimum wall thickness + 1mm and average deterioration rate)

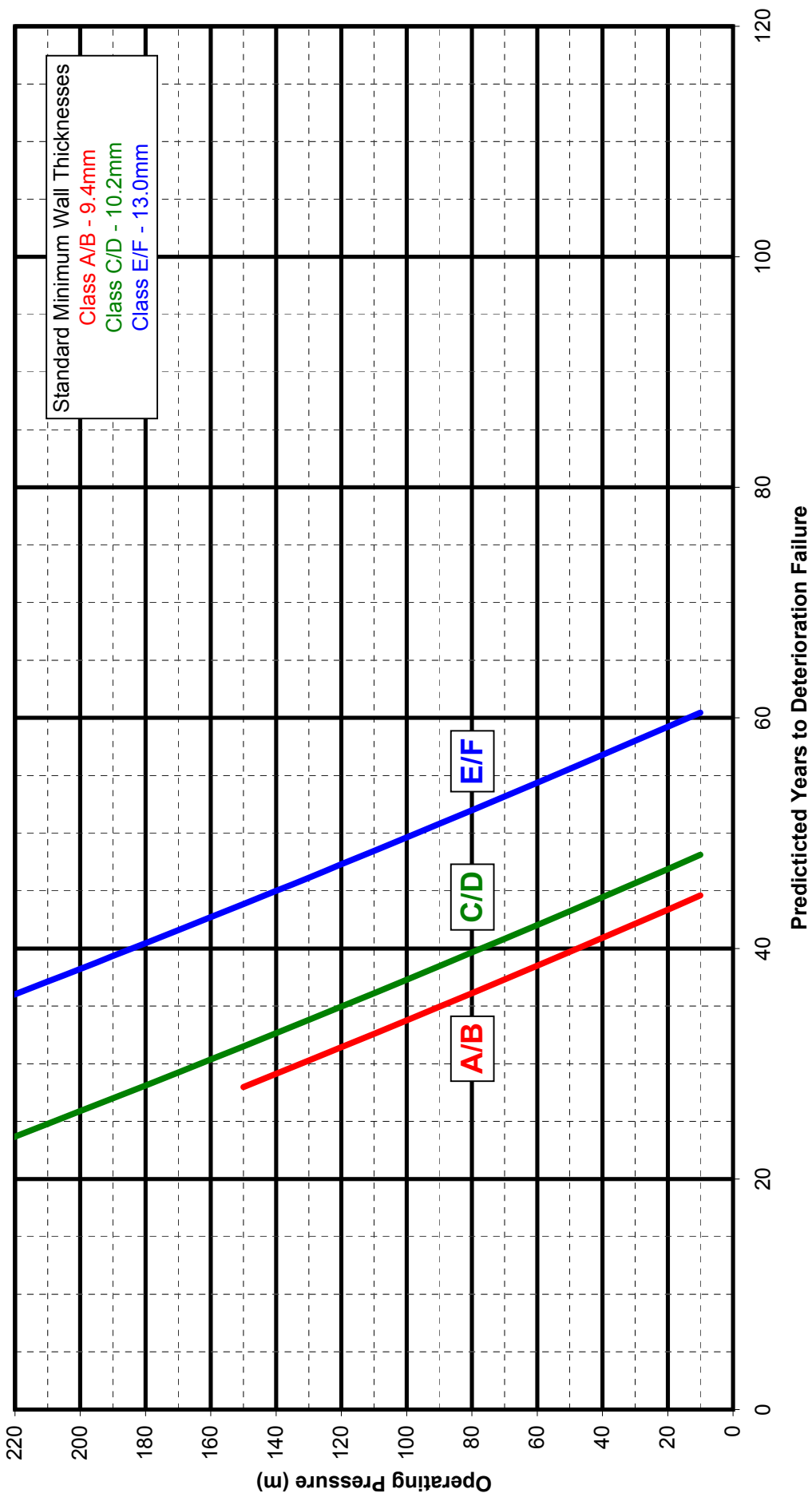

Standard Minimum Wall Thickness
 Class A/B - 9.4mm
 Class C/D - 10.2mm
 Class E/F - 13.0mm



Variable Detn Chart Calculations (80mm)

Pipe Class	Average WT (mm)	Standard Min Wt (mm)	Standard OD (mm)	Rates of Deterioration (mm/yr)										
80mm E/F	0.0	10.2	96	<table style="width: 100%; border-collapse: collapse;"> <tr> <td style="width: 50%;">85% (Upper)</td> <td style="width: 50%;">0.4000</td> </tr> <tr> <td>50% (Upper)</td> <td>0.2857</td> </tr> <tr> <td>Average Rate</td> <td>0.2269</td> </tr> <tr> <td>50% (Lower)</td> <td>0.1750</td> </tr> <tr> <td>85% (Lower)</td> <td>0.1222</td> </tr> </table>	85% (Upper)	0.4000	50% (Upper)	0.2857	Average Rate	0.2269	50% (Lower)	0.1750	85% (Lower)	0.1222
85% (Upper)	0.4000													
50% (Upper)	0.2857													
Average Rate	0.2269													
50% (Lower)	0.1750													
85% (Lower)	0.1222													
The Standard Minimum Wall Thickness + 1mm Will be Used for Lifetime Calculations														

Working Pressure (m)	Working Pressure + Surge (MPa)	Theoretical Min Wt (mm)	Det'n Causing Failure (mm)	Predicted Lifetimes				
				85% (Upper)	50% (Upper)	Average Rate	50% (Lower)	85% (Lower)
10	0.15	0.28	10.92	27	38	48	62	89
20	0.29	0.56	10.64	27	37	47	61	87
30	0.44	0.84	10.36	26	36	46	59	85
40	0.59	1.11	10.09	25	35	44	58	83
50	0.73	1.39	9.81	25	34	43	56	80
60	0.88	1.66	9.54	24	33	42	55	78
70	1.03	1.93	9.27	23	32	41	53	76
80	1.17	2.20	9.00	22	31	40	51	74
90	1.32	2.47	8.73	22	31	38	50	71
100	1.47	2.74	8.46	21	30	37	48	69
110	1.62	3.00	8.20	20	29	36	47	67
120	1.76	3.27	7.93	20	28	35	45	65
130	1.91	3.53	7.67	19	27	34	44	63
140	2.06	3.79	7.41	19	26	33	42	61
150	2.20	4.05	7.15	18	25	32	41	59
160	2.35	4.31	6.89	17	24	30	39	56
170	2.50	4.56	6.64	17	23	29	38	54
180	2.64	4.82	6.38	16	22	28	36	52
190	2.79	5.07	6.13	15	21	27	35	50
200	2.94	5.33	5.87	15	21	26	34	48
210	3.08	5.58	5.62	14	20	25	32	46
220	3.23	5.83	5.37	13	19	24	31	44
230	3.38	6.07	5.13	13	18	23	29	42



Lifetime Prediction Chart Showing Range of Predicted Years to Failure
(based on standard minimum wall thickness + 1mm)

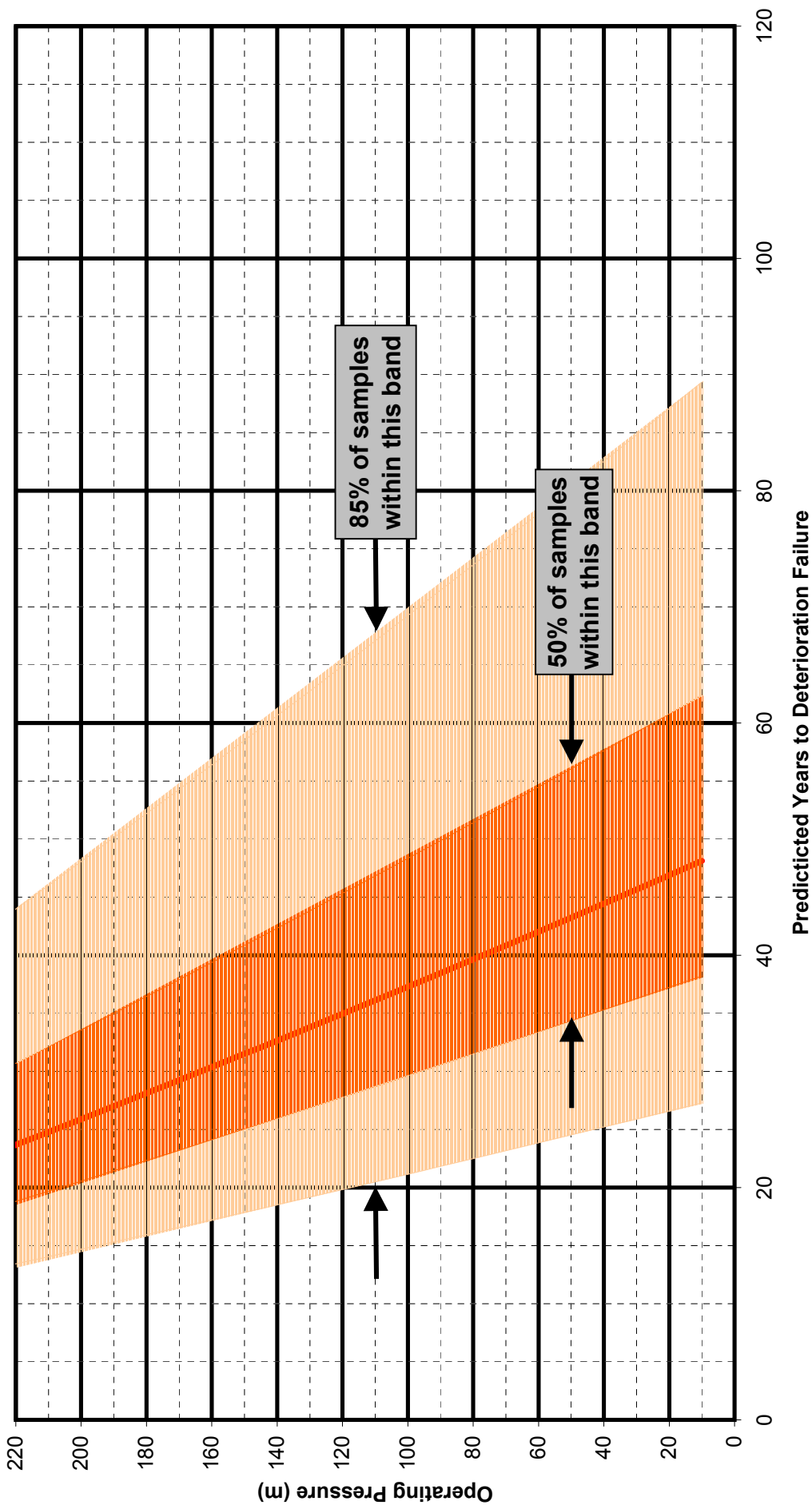



Lifetime Prediction Chart Calculations (100mm)

Pipe Class	Average Det'n Rate (mm/yr)	Average Wt (mm)	Standard Min Wt (mm)	Standard OD (mm)
100mm A/B	0.0	0.0	10.7	122
100mm C/D	0.0	0.0	12.7	122
100mm E/F	0.0	0.0	16.5	122

Working Pressure (m)	Working Pressure + Surge (MPa)	Theoretical Min Wt (mm)	Det'n Causing Failure (mm) 100mm A/B	Predicted Lifetime 100mm A/B	Det'n Causing Failure (mm) 100mm C/D	Predicted Lifetime 100mm C/D	Det'n Causing Failure (mm) 100mm E/F	Predicted Lifetime 100mm E/F
10	0.15	0.36	11.34	50	13.34	59	17.14	76
20	0.29	0.71	10.99	48	12.99	57	16.79	74
30	0.44	1.07	10.63	47	12.63	56	16.43	72
40	0.59	1.42	10.28	45	12.28	54	16.08	71
50	0.73	1.77	9.93	44	11.93	53	15.73	69
60	0.88	2.11	9.59	42	11.59	51	15.39	68
70	1.03	2.46	9.24	41	11.24	50	15.04	66
80	1.17	2.80	8.90	39	10.90	48	14.70	65
90	1.32	3.14	8.56	38	10.56	47	14.36	63
100	1.47	3.48	8.22	36	10.22	45	14.02	62
110	1.62	3.82	7.88	35	9.88	44	13.68	60
120	1.76	4.15	7.55	33	9.55	42	13.35	59
130	1.91	4.49	7.21	32	9.21	41	13.01	57
140	2.06	4.82	6.88	30	8.88	39	12.68	56
150	2.20	5.15	6.55	29	8.55	38	12.35	54
160	2.35	5.48			8.22	36	12.02	53
170	2.50	5.80			7.90	35	11.70	52
180	2.64	6.13			7.57	33	11.37	50
190	2.79	6.45			7.25	32	11.05	49
200	2.94	6.77			6.93	31	10.73	47
210	3.08	7.09			6.61	29	10.41	46
220	3.23	7.40			6.30	28	10.10	44
230	3.38	7.72			5.98	26	9.78	43



Lifetime Prediction Chart Showing Predicted Years to Failure
(based on standard minimum wall thickness + 1mm and average deterioration rate)

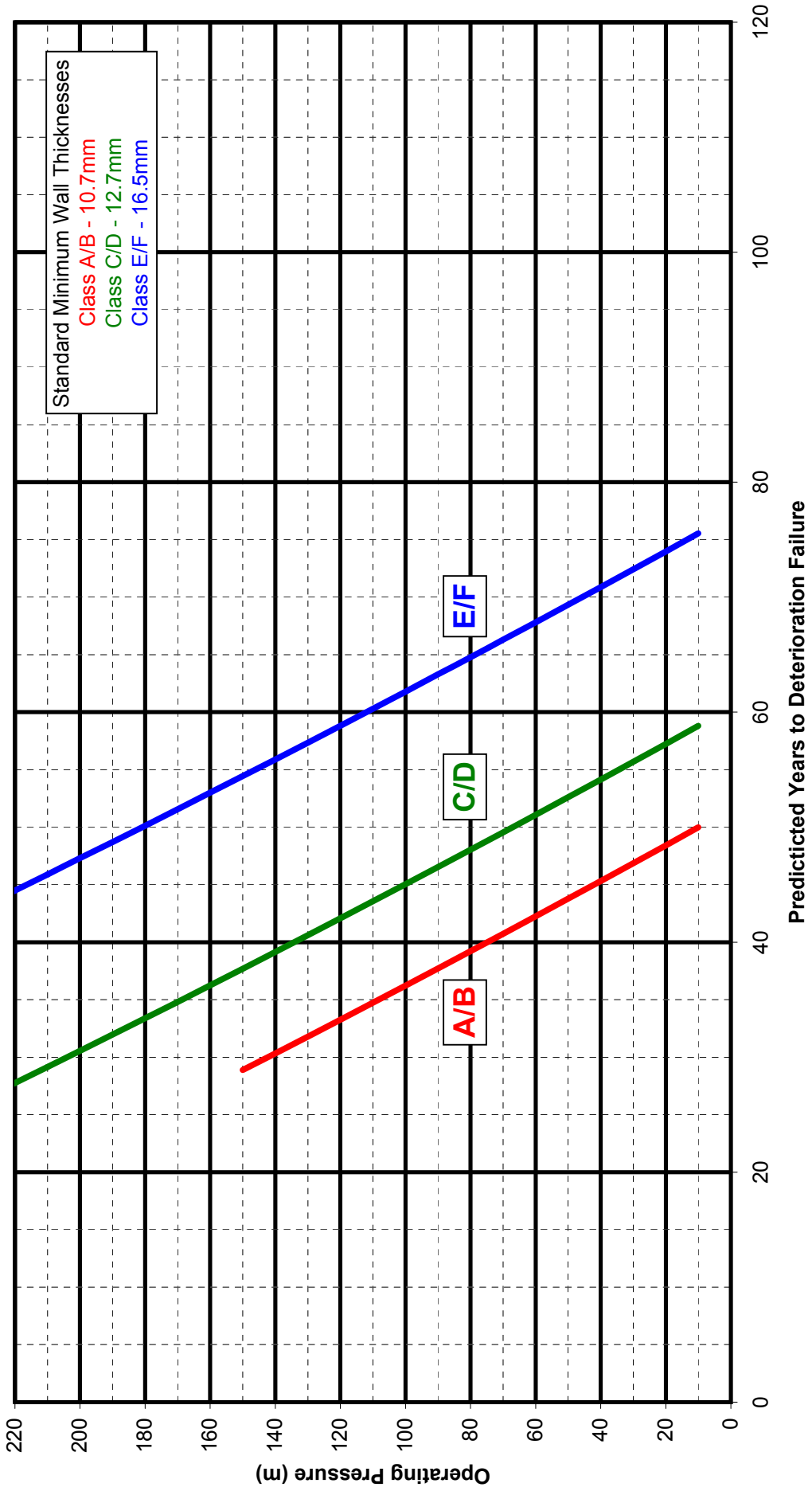



Variable Detn Chart Calculations (100mm)

Pipe Class	Average WT (mm)	Standard Min Wt (mm)	Standard OD (mm)	Rates of Deterioration (mm/yr)										
100mm C/D	0.0	12.7	122	<table style="width: 100%; border-collapse: collapse;"> <tr> <td style="width: 50%;">85% (Upper)</td> <td style="width: 50%;">0.4000</td> </tr> <tr> <td>50% (Upper)</td> <td>0.2857</td> </tr> <tr> <td style="text-align: center;">Average Rate</td> <td style="text-align: center;">0.2269</td> </tr> <tr> <td>50% (Lower)</td> <td>0.1750</td> </tr> <tr> <td>85% (Lower)</td> <td>0.1222</td> </tr> </table>	85% (Upper)	0.4000	50% (Upper)	0.2857	Average Rate	0.2269	50% (Lower)	0.1750	85% (Lower)	0.1222
85% (Upper)	0.4000													
50% (Upper)	0.2857													
Average Rate	0.2269													
50% (Lower)	0.1750													
85% (Lower)	0.1222													
The Standard Minimum Wall Thickness + 1 mm Will be Used for Lifetime Calculations														

Working Pressure (m)	Working Pressure + Surge (MPa)	Theoretical Min Wt (mm)	Det'n Causing Failure (mm)	Predicted Lifetimes				
				85% (Upper)	50% (Upper)	Average Rate	50% (Lower)	85% (Lower)
10	0.15	0.36	13.34	33	47	59	76	109
20	0.29	0.71	12.99	32	45	57	74	106
30	0.44	1.07	12.63	32	44	56	72	103
40	0.59	1.42	12.28	31	43	54	70	101
50	0.73	1.77	11.93	30	42	53	68	98
60	0.88	2.11	11.59	29	41	51	66	95
70	1.03	2.46	11.24	28	39	50	64	92
80	1.17	2.80	10.90	27	38	48	62	89
90	1.32	3.14	10.56	26	37	47	60	86
100	1.47	3.48	10.22	26	36	45	58	84
110	1.62	3.82	9.88	25	35	44	56	81
120	1.76	4.15	9.55	24	33	42	55	78
130	1.91	4.49	9.21	23	32	41	53	75
140	2.06	4.82	8.88	22	31	39	51	73
150	2.20	5.15	8.55	21	30	38	49	70
160	2.35	5.48	8.22	21	29	36	47	67
170	2.50	5.80	7.90	20	28	35	45	65
180	2.64	6.13	7.57	19	27	33	43	62
190	2.79	6.45	7.25	18	25	32	41	59
200	2.94	6.77	6.93	17	24	31	40	57
210	3.08	7.09	6.61	17	23	29	38	54
220	3.23	7.40	6.30	16	22	28	36	52
230	3.38	7.72	5.98	15	21	26	34	49



Lifetime Prediction Chart Showing Range of Predicted Years to Failure
(based on standard minimum wall thickness + 1mm)

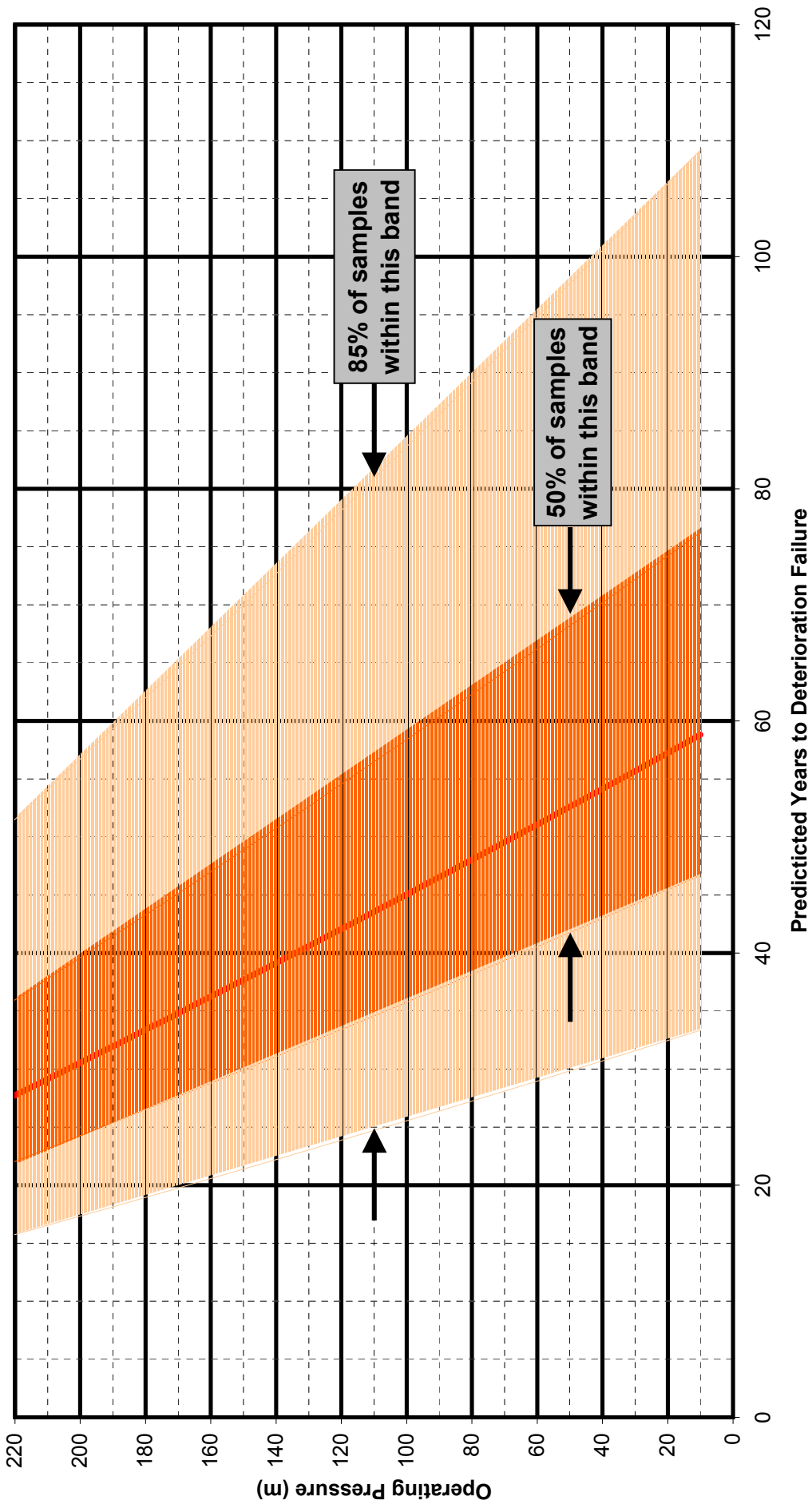



Lifetime Prediction Chart Calculations (150mm)

Pipe Class	Average Det'n Rate (mm/yr)	Average Wt (mm)	Standard Min Wt (mm)	Standard OD (mm)
150mm A/B	0.2269	0.0	11.4	178
150mm C	0.2269	0.0	15.5	178
150mm D	0.2269	0.0	17.8	178
150mm E	0.2269	0.0	19.1	178
150mm F	0.2269	0.0	21.9	178

Working Pressure (m)	Working Pressure + Surge (MPa)	Theoretical Min Wt (mm)	150mm A/B		150mm C		150mm D		150mm E		150mm F	
			Det'n Causing Failure (mm)	Predicted Lifetime	Det'n Causing Failure (mm)	Predicted Lifetime	Det'n Causing Failure (mm)	Predicted Lifetime	Det'n Causing Failure (mm)	Predicted Lifetime	Det'n Causing Failure (mm)	Predicted Lifetime
10	0.15	0.52	11.88	52	15.98	70	18.28	81	19.58	86	22.38	90
20	0.29	1.04	11.36	50	15.46	68	17.76	78	19.06	84	21.86	96
30	0.44	1.55	10.85	48	14.95	66	17.25	76	18.55	82	21.35	94
40	0.59	2.07	10.33	46	14.43	64	16.73	74	18.03	79	20.83	92
50	0.73	2.58	9.82	43	13.92	61	16.22	72	17.52	77	20.32	90
60	0.88	3.08	9.32	41	13.42	59	15.72	69	17.02	75	19.82	87
70	1.03	3.59	8.81	39	12.91	57	15.21	67	16.51	73	19.31	85
80	1.17	4.09	8.31	37	12.41	55	14.71	65	16.01	71	18.81	83
90	1.32	4.58	7.82	34	11.92	53	14.22	63	15.52	68	18.32	81
100	1.47	5.08	7.32	32	11.42	50	13.72	60	15.02	66	17.82	79
110	1.62	5.57	6.83	30	10.93	48	13.23	58	14.53	64	17.33	76
120	1.76	6.06	6.34	28	10.44	46	12.74	56	14.04	62	16.84	74
130	1.91	6.55	5.85	26	9.95	44	12.25	54	13.55	60	16.35	72
140	2.06	7.03	5.37	24	9.47	42	11.77	52	13.07	58	15.87	70
150	2.20	7.51	4.89	22	8.99	40	11.29	50	12.59	55	15.39	68
160	2.35	7.99			8.51	38	10.81	48	12.11	53	14.91	66
170	2.50	8.46			8.04	35	10.34	46	11.64	51	14.44	64
180	2.64	8.94			7.56	33	9.86	43	11.16	49	13.96	62
190	2.79	9.41			7.09	31	9.39	41	10.69	47	13.49	59
200	2.94	9.87			6.63	29	8.93	39	10.23	45	13.03	57
210	3.08	10.34			6.16	27	8.46	37	9.76	43	12.56	55
220	3.23	10.80			5.70	25	8.00	35	9.30	41	12.10	53
230	3.38	11.26			5.24	23	7.54	33	8.84	39	11.64	51



Lifetime Prediction Chart Showing Predicted Years to Failure
(based on standard minimum wall thickness + 1mm and average deterioration rate)

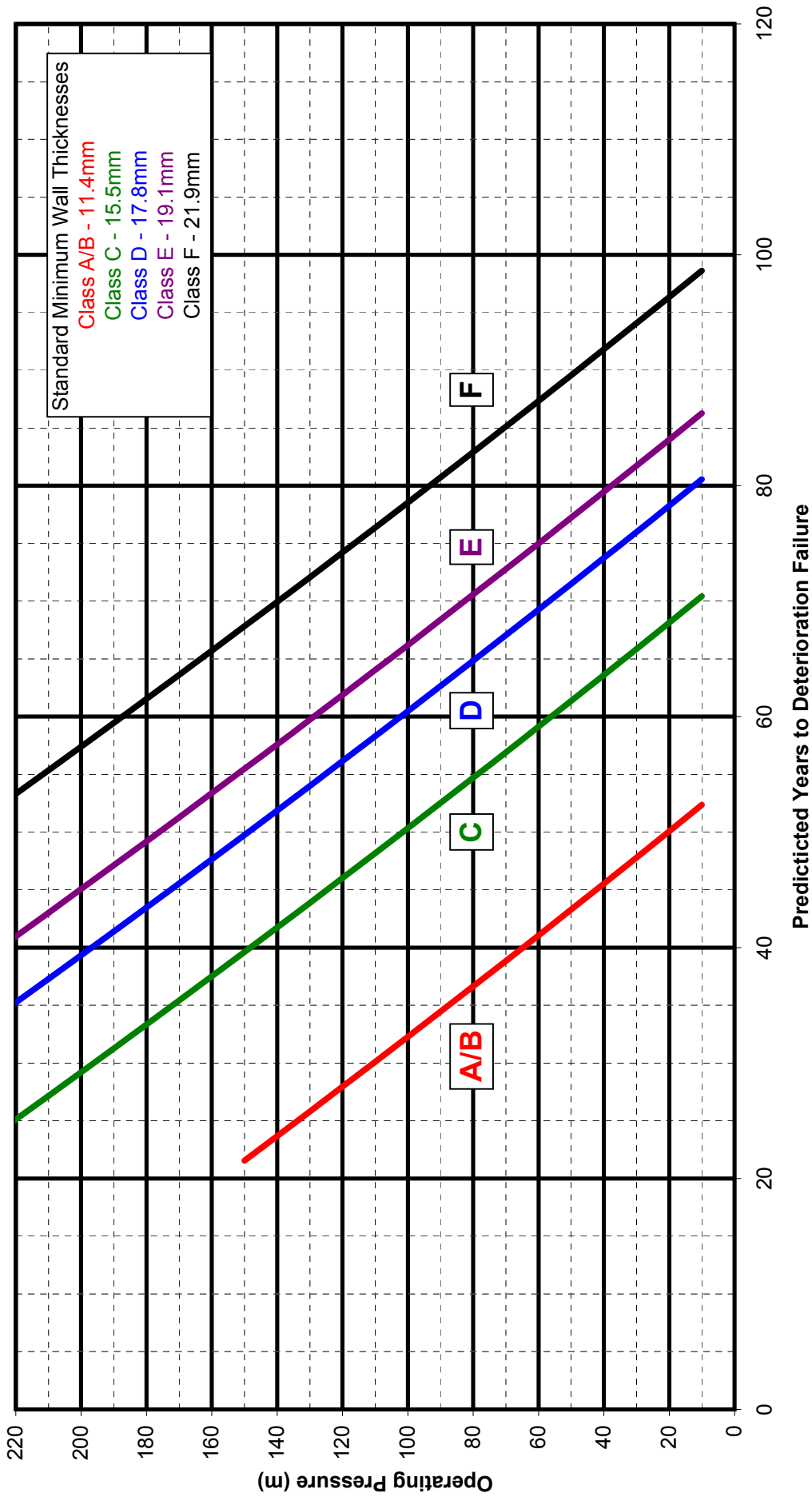



Variable Detn Chart Calculations (150mm)

Pipe Class	Average WT (mm)	Standard Min Wt (mm)	Standard OD (mm)	Rates of Deterioration (mm/yr)										
150mm C	0.0	15.5	178	<table style="width: 100%; border-collapse: collapse;"> <tr> <td style="width: 50%;">85% (Upper)</td> <td style="width: 50%;">0.4000</td> </tr> <tr> <td>50% (Upper)</td> <td>0.2857</td> </tr> <tr> <td>Average Rate</td> <td>0.2269</td> </tr> <tr> <td>50% (Lower)</td> <td>0.1750</td> </tr> <tr> <td>85% (Lower)</td> <td>0.1222</td> </tr> </table>	85% (Upper)	0.4000	50% (Upper)	0.2857	Average Rate	0.2269	50% (Lower)	0.1750	85% (Lower)	0.1222
85% (Upper)	0.4000													
50% (Upper)	0.2857													
Average Rate	0.2269													
50% (Lower)	0.1750													
85% (Lower)	0.1222													
The Standard Minimum Wall Thickness + 1mm Will be Used for Lifetime Calculations														

Working Pressure (m)	Working Pressure + Surge (MPa)	Theoretical Min Wt (mm)	Det'n Causing Failure (mm)	Predicted Lifetimes				
				85% (Upper)	50% (Upper)	Average Rate	50% (Lower)	85% (Lower)
10	0.15	0.52	15.98	40	56	70	91	131
20	0.29	1.04	15.46	39	54	68	88	127
30	0.44	1.55	14.95	37	52	66	85	122
40	0.59	2.07	14.43	36	51	64	82	118
50	0.73	2.58	13.92	35	49	61	80	114
60	0.88	3.08	13.42	34	47	59	77	110
70	1.03	3.59	12.91	32	45	57	74	106
80	1.17	4.09	12.41	31	43	55	71	102
90	1.32	4.58	11.92	30	42	53	68	98
100	1.47	5.08	11.42	29	40	50	65	93
110	1.62	5.57	10.93	27	38	48	62	89
120	1.76	6.06	10.44	26	37	46	60	85
130	1.91	6.55	9.95	25	35	44	57	81
140	2.06	7.03	9.47	24	33	42	54	78
150	2.20	7.51	8.99	22	31	40	51	74
160	2.35	7.99	8.51	21	30	38	49	70
170	2.50	8.46	8.04	20	28	35	46	66
180	2.64	8.94	7.56	19	26	33	43	62
190	2.79	9.41	7.09	18	25	31	41	58
200	2.94	9.87	6.63	17	23	29	38	54
210	3.08	10.34	6.16	15	22	27	35	50
220	3.23	10.80	5.70	14	20	25	33	47
230	3.38	11.26	5.24	13	18	23	30	43

150 mm Class C

Lifetime Prediction Chart Showing Range of Predicted Years to Failure
(based on standard minimum wall thickness + 1mm)

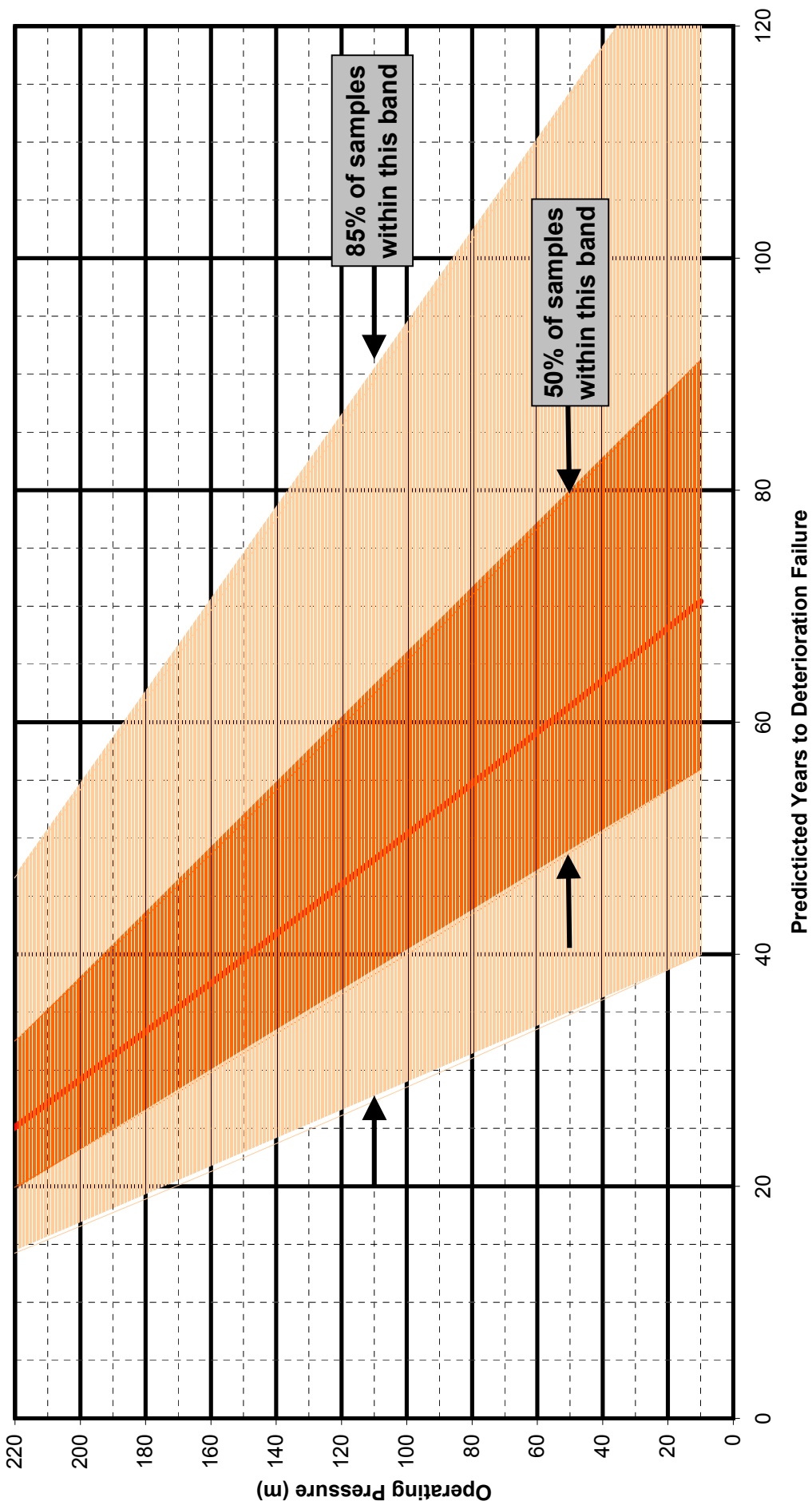



Lifetime Prediction Chart Calculations (200mm)

Pipe Class	Average Det'n Rate (mm/yr)	Average Wt (mm)	Standard Min Wt (mm)	Standard OD (mm)
200mm A	0.2269	0.0	12	233
200mm B	0.2269	0.0	14.5	233
200mm C	0.2269	0.0	18.3	233
200mm D	0.2269	0.0	22.9	233

Working Pressure (m)	Working Pressure + Surge (MPa)	Theoretical Min Wt (mm)	200mm A		200mm B		200mm C		200mm D	
			Det'n Causing Failure (mm)	Predicted Lifetime	Det'n Causing Failure (mm)	Predicted Lifetime	Det'n Causing Failure (mm)	Predicted Lifetime	Det'n Causing Failure (mm)	Predicted Lifetime
10	0.15	0.68	12.32	54	14.82	65	18.62	82	23.22	102
20	0.29	1.36	11.64	51	14.14	62	17.94	79	22.54	99
30	0.44	2.03	10.97	48	13.47	59	17.27	76	21.87	96
40	0.59	2.71	10.29	45	12.79	56	16.59	73	21.19	93
50	0.73	3.37	9.63	42	12.13	53	15.93	70	20.53	90
60	0.88	4.03	8.97	40	11.47	51	15.27	67	19.87	88
70	1.03	4.69	8.31	37	10.81	48	14.61	64	19.21	85
80	1.17	5.35	7.65	34	10.15	45	13.95	61	18.55	82
90	1.32	6.00	7.00	31	9.50	42	13.30	59	17.90	79
100	1.47	6.65	6.35	28	8.85	39	12.65	56	17.25	76
110	1.62	7.29	5.71	25	8.21	36	12.01	53	16.61	73
120	1.76	7.93	5.07	22	7.57	33	11.37	50	15.97	70
130	1.91	8.57	4.43	20	6.93	31	10.73	47	15.33	68
140	2.06	9.20	3.80	17	6.30	28	10.10	45	14.70	65
150	2.20	9.83	3.17	14	5.67	25	9.47	42	14.07	62
160	2.35	10.46			5.04	22	8.84	39	13.44	59
170	2.50	11.08			4.42	19	8.22	36	12.82	57
180	2.64	11.70			3.80	17	7.60	34	12.20	54
190	2.79	12.31			3.19	14	6.99	31	11.59	51
200	2.94	12.93			2.57	11	6.37	28	10.97	48
210	3.08	13.53			1.97	9	5.77	25	10.37	46
220	3.23	14.14			1.36	6	5.16	23	9.76	43
230	3.38	14.74			0.76	3	4.56	20	9.16	40



Lifetime Prediction Chart Showing Predicted Years to Failure
(based on standard minimum wall thickness + 1mm and average deterioration rate)

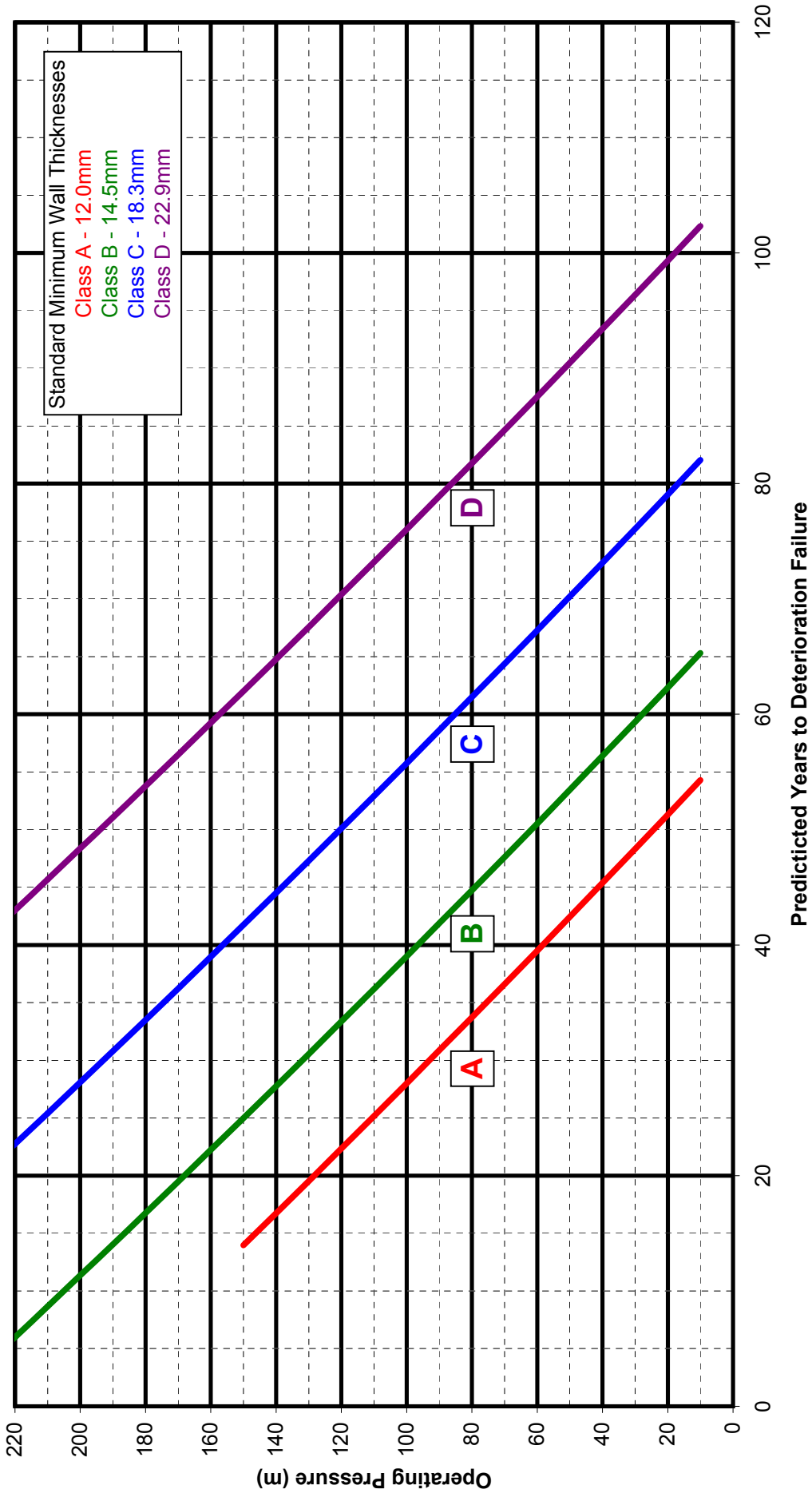



Variable Detn Chart Calculations (200mm)

Pipe Class	Average WT (mm)	Standard Min Wt (mm)	Standard OD (mm)	Rates of Deterioration (mm/yr)										
200mm C	0.0	18.3	233	<table style="width: 100%; border-collapse: collapse;"> <tr> <td style="width: 50%;">85% (Upper)</td> <td style="width: 50%;">0.4000</td> </tr> <tr> <td>50% (Upper)</td> <td>0.2857</td> </tr> <tr> <td>Average Rate</td> <td>0.2269</td> </tr> <tr> <td>50% (Lower)</td> <td>0.1750</td> </tr> <tr> <td>85% (Lower)</td> <td>0.1222</td> </tr> </table>	85% (Upper)	0.4000	50% (Upper)	0.2857	Average Rate	0.2269	50% (Lower)	0.1750	85% (Lower)	0.1222
85% (Upper)	0.4000													
50% (Upper)	0.2857													
Average Rate	0.2269													
50% (Lower)	0.1750													
85% (Lower)	0.1222													
The Standard Minimum Wall Thickness + 1mm Will be Used for Lifetime Calculations														

Working Pressure (m)	Working Pressure + Surge (MPa)	Theoretical Min Wt (mm)	Det'n Causing Failure (mm)	Predicted Lifetimes				
				85% (Upper)	50% (Upper)	Average Rate	50% (Lower)	85% (Lower)
10	0.15	0.68	18.62	47	65	82	106	152
20	0.29	1.36	17.94	45	63	79	103	147
30	0.44	2.03	17.27	43	60	76	99	141
40	0.59	2.71	16.59	41	58	73	95	136
50	0.73	3.37	15.93	40	56	70	91	130
60	0.88	4.03	15.27	38	53	67	87	125
70	1.03	4.69	14.61	37	51	64	83	120
80	1.17	5.35	13.95	35	49	61	80	114
90	1.32	6.00	13.30	33	47	59	76	109
100	1.47	6.65	12.65	32	44	56	72	104
110	1.62	7.29	12.01	30	42	53	69	98
120	1.76	7.93	11.37	28	40	50	65	93
130	1.91	8.57	10.73	27	38	47	61	88
140	2.06	9.20	10.10	25	35	45	58	83
150	2.20	9.83	9.47	24	33	42	54	77
160	2.35	10.46	8.84	22	31	39	51	72
170	2.50	11.08	8.22	21	29	36	47	67
180	2.64	11.70	7.60	19	27	34	43	62
190	2.79	12.31	6.99	17	24	31	40	57
200	2.94	12.93	6.37	16	22	28	36	52
210	3.08	13.53	5.77	14	20	25	33	47
220	3.23	14.14	5.16	13	18	23	29	42
230	3.38	14.74	4.56	11	16	20	26	37



Lifetime Prediction Chart Showing Range of Predicted Years to Failure
(based on standard minimum wall thickness + 1mm)

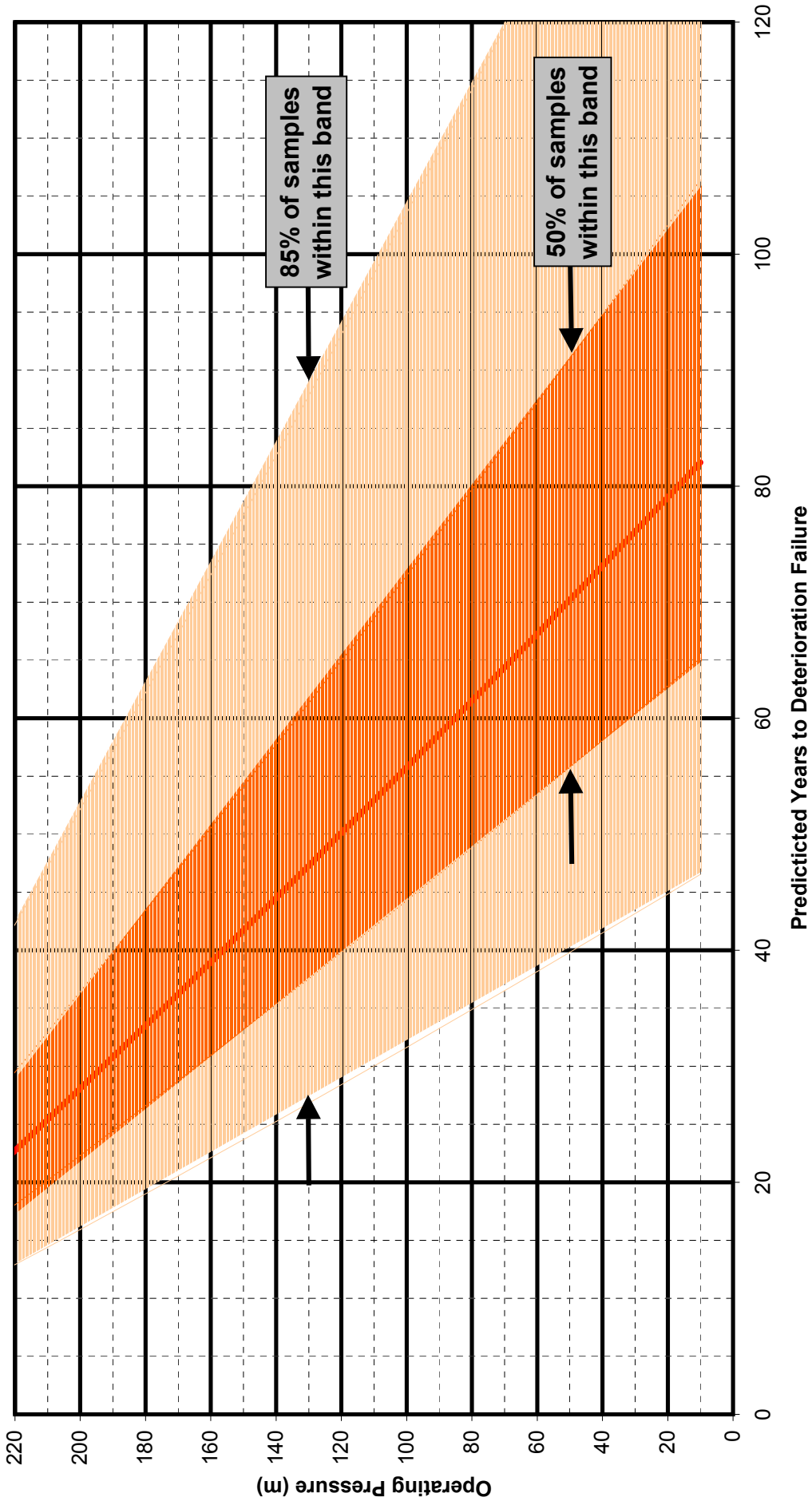



Lifetime Prediction Chart Calculations (225mm)

Pipe Class	Average Det'n Rate (mm/yr)	Average Wt (mm)	Standard Min Wt (mm)	Standard OD (mm)
225mm A	0.2269	0.0	12.7	260
225mm B	0.2269	0.0	15.3	260
225mm C	0.2269	0.0	20.1	260
225mm D	0.2269	0.0	24.9	260

Working Pressure (m)	Working Pressure + Surge (MPa)	Theoretical Min Wt (mm)	225mm A		225mm B		225mm C		225mm D	
			Det'n Causing Failure (mm)	Predicted Lifetime	Det'n Causing Failure (mm)	Predicted Lifetime	Det'n Causing Failure (mm)	Predicted Lifetime	Det'n Causing Failure (mm)	Predicted Lifetime
10	0.15	0.76	12.94	57	15.54	68	20.34	90	25.14	111
20	0.29	1.52	12.18	54	14.78	65	19.58	86	24.38	107
30	0.44	2.27	11.43	50	14.03	62	18.83	83	23.63	104
40	0.59	3.02	10.68	47	13.28	59	18.08	80	22.88	101
50	0.73	3.76	9.94	44	12.54	55	17.34	76	22.14	98
60	0.88	4.50	9.20	41	11.80	52	16.60	73	21.40	94
70	1.03	5.24	8.46	37	11.06	49	15.86	70	20.66	91
80	1.17	5.97	7.73	34	10.33	46	15.13	67	19.93	88
90	1.32	6.69	7.01	31	9.61	42	14.41	63	19.21	85
100	1.47	7.42	6.28	28	8.88	39	13.68	60	18.48	81
110	1.62	8.14	5.56	25	8.16	36	12.96	57	17.76	78
120	1.76	8.85	4.85	21	7.45	33	12.25	54	17.05	75
130	1.91	9.56	4.14	18	6.74	30	11.54	51	16.34	72
140	2.06	10.27	3.43	15	6.03	27	10.83	48	15.63	69
150	2.20	10.97	2.73	12	5.33	23	10.13	45	14.93	66
160	2.35	11.67			4.63	20	9.43	42	14.23	63
170	2.50	12.36			3.94	17	8.74	39	13.54	60
180	2.64	13.05			3.25	14	8.05	35	12.85	57
190	2.79	13.74			2.56	11	7.36	32	12.16	54
200	2.94	14.42			1.88	8	6.68	29	11.48	51
210	3.08	15.10			1.20	5	6.00	26	10.80	48
220	3.23	15.78			0.52	2	5.32	23	10.12	45
230	3.38	16.45			-0.15	-1	4.65	20	9.45	42



Lifetime Prediction Chart Showing Predicted Years to Failure
(based on standard minimum wall thickness + 1mm and average deterioration rate)

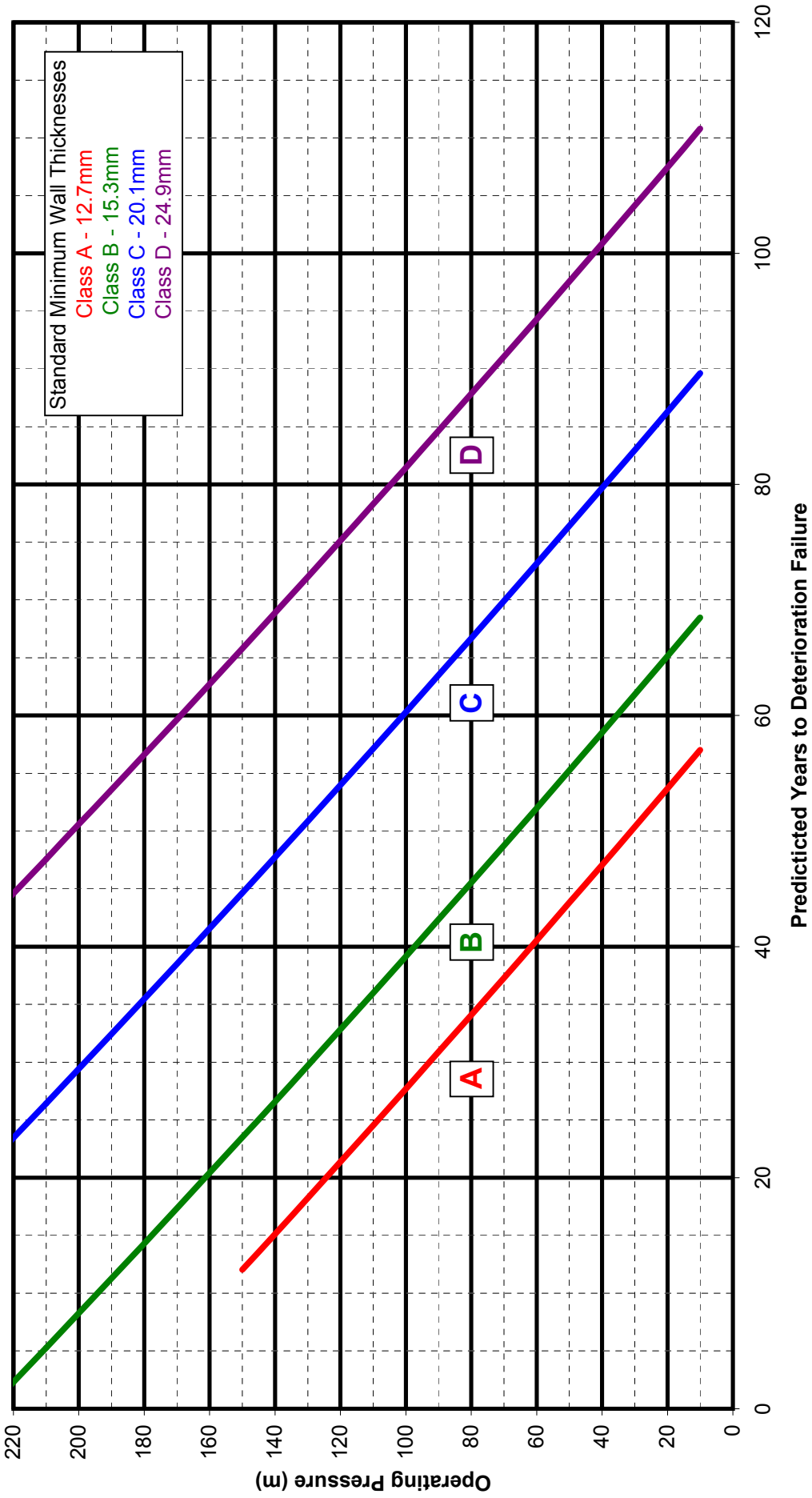



Variable Detn Chart Calculations (225mm)

Pipe Class	Average WT (mm)	Standard Min Wt (mm)	Standard OD (mm)	Rates of Deterioration (mm/yr)										
225mm C	0.0	20.1	260	<table style="width: 100%; border-collapse: collapse;"> <tr> <td style="width: 50%;">85% (Upper)</td> <td style="width: 50%;">0.4000</td> </tr> <tr> <td>50% (Upper)</td> <td>0.2857</td> </tr> <tr> <td>Average Rate</td> <td>0.2269</td> </tr> <tr> <td>50% (Lower)</td> <td>0.1750</td> </tr> <tr> <td>85% (Lower)</td> <td>0.1222</td> </tr> </table>	85% (Upper)	0.4000	50% (Upper)	0.2857	Average Rate	0.2269	50% (Lower)	0.1750	85% (Lower)	0.1222
85% (Upper)	0.4000													
50% (Upper)	0.2857													
Average Rate	0.2269													
50% (Lower)	0.1750													
85% (Lower)	0.1222													
The Standard Minimum Wall Thickness + 1 mm Will be Used for Lifetime Calculations														

Working Pressure (m)	Working Pressure + Surge (MPa)	Theoretical Min Wt (mm)	Det'n Causing Failure (mm)	Predicted Lifetimes				
				85% (Upper)	50% (Upper)	Average Rate	50% (Lower)	85% (Lower)
10	0.15	0.76	20.34	51	71	90	116	166
20	0.29	1.52	19.58	49	69	86	112	160
30	0.44	2.27	18.83	47	66	83	108	154
40	0.59	3.02	18.08	45	63	80	103	148
50	0.73	3.76	17.34	43	61	76	99	142
60	0.88	4.50	16.60	41	58	73	95	136
70	1.03	5.24	15.86	40	56	70	91	130
80	1.17	5.97	15.13	38	53	67	86	124
90	1.32	6.69	14.41	36	50	63	82	118
100	1.47	7.42	13.68	34	48	60	78	112
110	1.62	8.14	12.96	32	45	57	74	106
120	1.76	8.85	12.25	31	43	54	70	100
130	1.91	9.56	11.54	29	40	51	66	94
140	2.06	10.27	10.83	27	38	48	62	89
150	2.20	10.97	10.13	25	35	45	58	83
160	2.35	11.67	9.43	24	33	42	54	77
170	2.50	12.36	8.74	22	31	39	50	71
180	2.64	13.05	8.05	20	28	35	46	66
190	2.79	13.74	7.36	18	26	32	42	60
200	2.94	14.42	6.68	17	23	29	38	55
210	3.08	15.10	6.00	15	21	26	34	49
220	3.23	15.78	5.32	13	19	23	30	44
230	3.38	16.45	4.65	12	16	20	27	38



Lifetime Prediction Chart Showing Range of Predicted Years to Failure
(based on standard minimum wall thickness + 1mm)

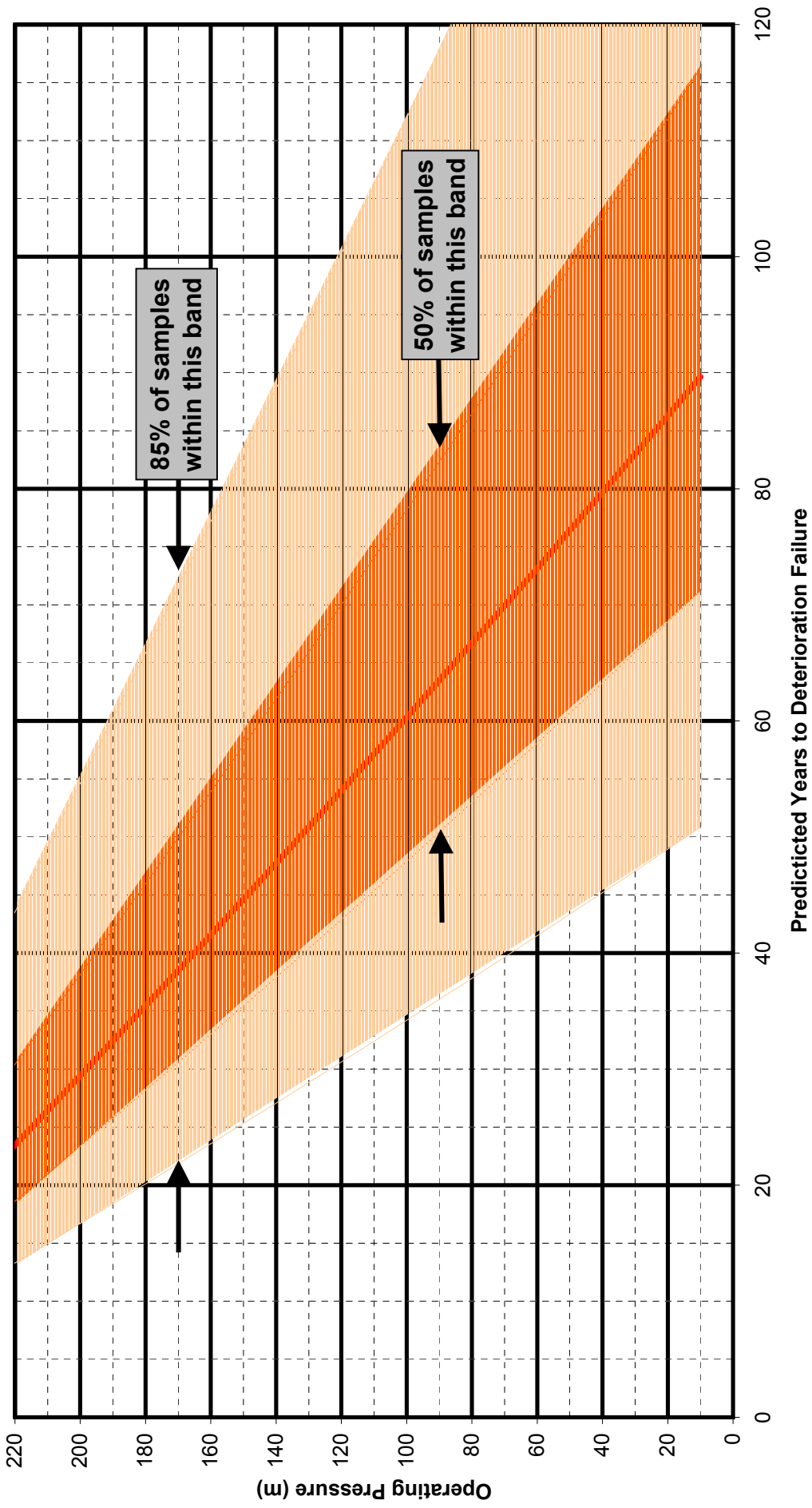



Lifetime Prediction Chart Calculations (250mm)

Pipe Class	Average Det'n Rate (mm/yr)	Average Wt (mm)	Standard Min Wt (mm)	Standard OD (mm)
250mm A	0.2269	0.0	13.2	287
250mm B	0.2269	0.0	16.3	287
250mm C	0.2269	0.0	21.3	287
250mm D	0.2269	0.0	27.5	287

Working Pressure (m)	Working Pressure + Surge (MPa)	Theoretical Min Wt (mm)	250mm A		250mm B		250mm C		250mm D	
			Det'n Causing Failure (mm)	Predicted Lifetime	Det'n Causing Failure (mm)	Predicted Lifetime	Det'n Causing Failure (mm)	Predicted Lifetime	Det'n Causing Failure (mm)	Predicted Lifetime
10	0.15	0.84	13.36	59	16.46	73	21.46	95	27.66	122
20	0.29	1.68	12.52	55	15.62	69	20.62	91	26.82	118
30	0.44	2.51	11.69	52	14.79	65	19.79	87	25.99	115
40	0.59	3.33	10.87	48	13.97	62	18.97	84	25.17	111
50	0.73	4.15	10.05	44	13.15	58	18.15	80	24.35	107
60	0.88	4.97	9.23	41	12.33	54	17.33	76	23.53	104
70	1.03	5.78	8.42	37	11.52	51	16.52	73	22.72	100
80	1.17	6.59	7.61	34	10.71	47	15.71	69	21.91	97
90	1.32	7.39	6.81	30	9.91	44	14.91	66	21.11	93
100	1.47	8.19	6.01	26	9.11	40	14.11	62	20.31	90
110	1.62	8.98	5.22	23	8.32	37	13.32	59	19.52	86
120	1.76	9.77	4.43	20	7.53	33	12.53	55	18.73	83
130	1.91	10.55	3.65	16	6.75	30	11.75	52	17.95	79
140	2.06	11.33	2.87	13	5.97	26	10.97	48	17.17	76
150	2.20	12.11	2.09	9	5.19	23	10.19	45	16.39	72
160	2.35	12.88			4.42	19	9.42	42	15.62	69
170	2.50	13.65			3.65	16	8.65	38	14.85	65
180	2.64	14.41			2.89	13	7.89	35	14.09	62
190	2.79	15.17			2.13	9	7.13	31	13.33	59
200	2.94	15.92			1.38	6	6.38	28	12.58	55
210	3.08	16.67			0.63	3	5.63	25	11.83	52
220	3.23	17.42			-0.12	-1	4.88	22	11.08	49
230	3.38	18.16			-0.86	-4	4.14	18	10.34	46



Lifetime Prediction Chart Showing Predicted Years to Failure
(based on standard minimum wall thickness + 1mm and average deterioration rate)

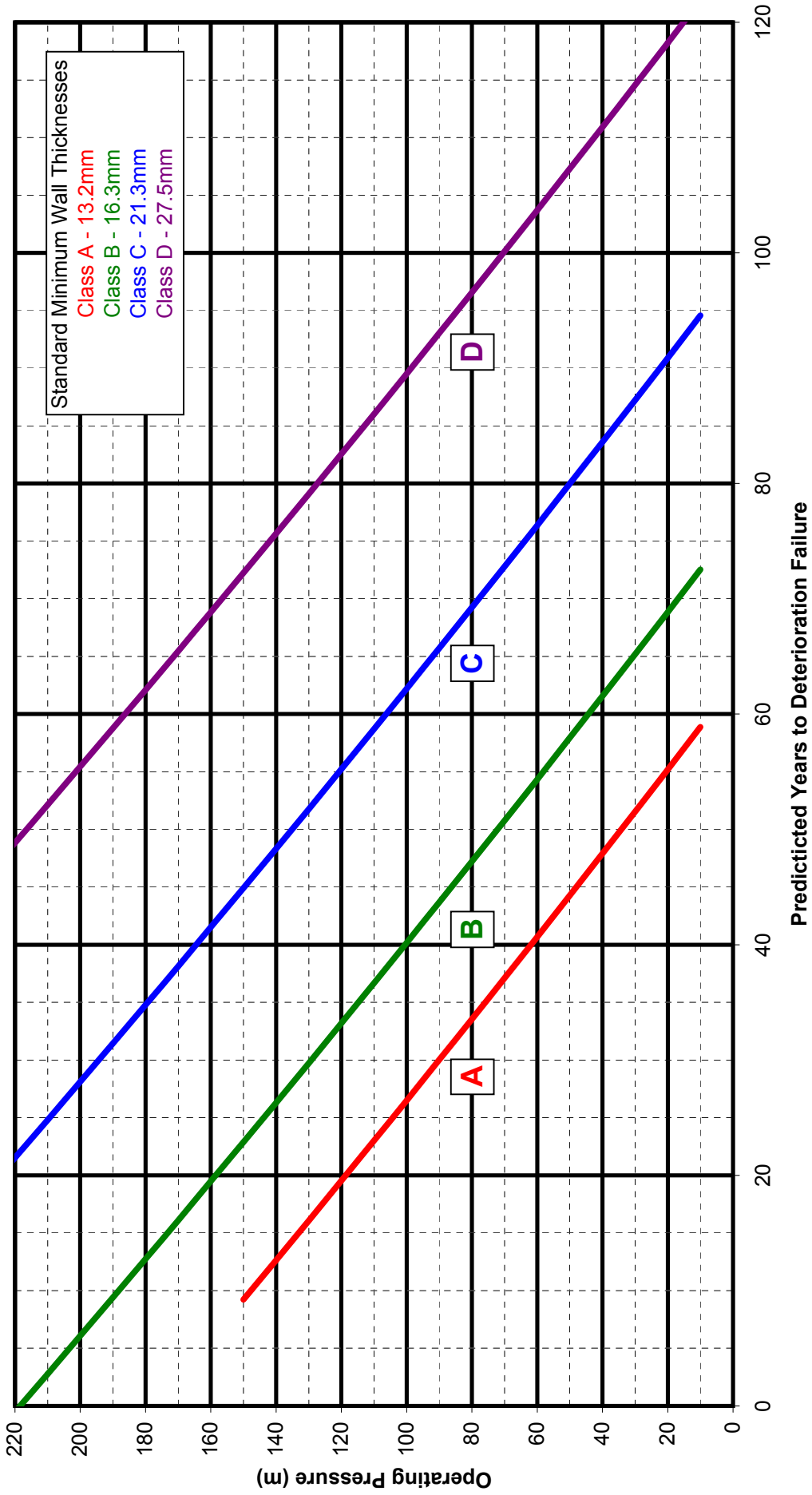



Variable Detn Chart Calculations (250mm)

Pipe Class	Average WT (mm)	Standard Min Wt (mm)	Standard OD (mm)	Rates of Deterioration (mm/yr)										
250mm C	0.0	21.3	287	<table style="width: 100%; border-collapse: collapse;"> <tr> <td style="width: 50%;">85% (Upper)</td> <td style="width: 50%;">0.4000</td> </tr> <tr> <td>50% (Upper)</td> <td>0.2857</td> </tr> <tr> <td>Average Rate</td> <td>0.2269</td> </tr> <tr> <td>50% (Lower)</td> <td>0.1750</td> </tr> <tr> <td>85% (Lower)</td> <td>0.1222</td> </tr> </table>	85% (Upper)	0.4000	50% (Upper)	0.2857	Average Rate	0.2269	50% (Lower)	0.1750	85% (Lower)	0.1222
85% (Upper)	0.4000													
50% (Upper)	0.2857													
Average Rate	0.2269													
50% (Lower)	0.1750													
85% (Lower)	0.1222													
The Standard Minimum Wall Thickness + 1 mm Will be Used for Lifetime Calculations														

Working Pressure (m)	Working Pressure + Surge (MPa)	Theoretical Min Wt (mm)	Det'n Causing Failure (mm)	Predicted Lifetimes				
				85% (Upper)	50% (Upper)	Average Rate	50% (Lower)	85% (Lower)
10	0.15	0.84	21.46	54	75	95	123	176
20	0.29	1.68	20.62	52	72	91	118	169
30	0.44	2.51	19.79	49	69	87	113	162
40	0.59	3.33	18.97	47	66	84	108	155
50	0.73	4.15	18.15	45	64	80	104	149
60	0.88	4.97	17.33	43	61	76	99	142
70	1.03	5.78	16.52	41	58	73	94	135
80	1.17	6.59	15.71	39	55	69	90	129
90	1.32	7.39	14.91	37	52	66	85	122
100	1.47	8.19	14.11	35	49	62	81	115
110	1.62	8.98	13.32	33	47	59	76	109
120	1.76	9.77	12.53	31	44	55	72	103
130	1.91	10.55	11.75	29	41	52	67	96
140	2.06	11.33	10.97	27	38	48	63	90
150	2.20	12.11	10.19	25	36	45	58	83
160	2.35	12.88	9.42	24	33	42	54	77
170	2.50	13.65	8.65	22	30	38	49	71
180	2.64	14.41	7.89	20	28	35	45	65
190	2.79	15.17	7.13	18	25	31	41	58
200	2.94	15.92	6.38	16	22	28	36	52
210	3.08	16.67	5.63	14	20	25	32	46
220	3.23	17.42	4.88	12	17	22	28	40
230	3.38	18.16	4.14	10	14	18	24	34



Lifetime Prediction Chart Showing Range of Predicted Years to Failure
(based on standard minimum wall thickness + 1mm)

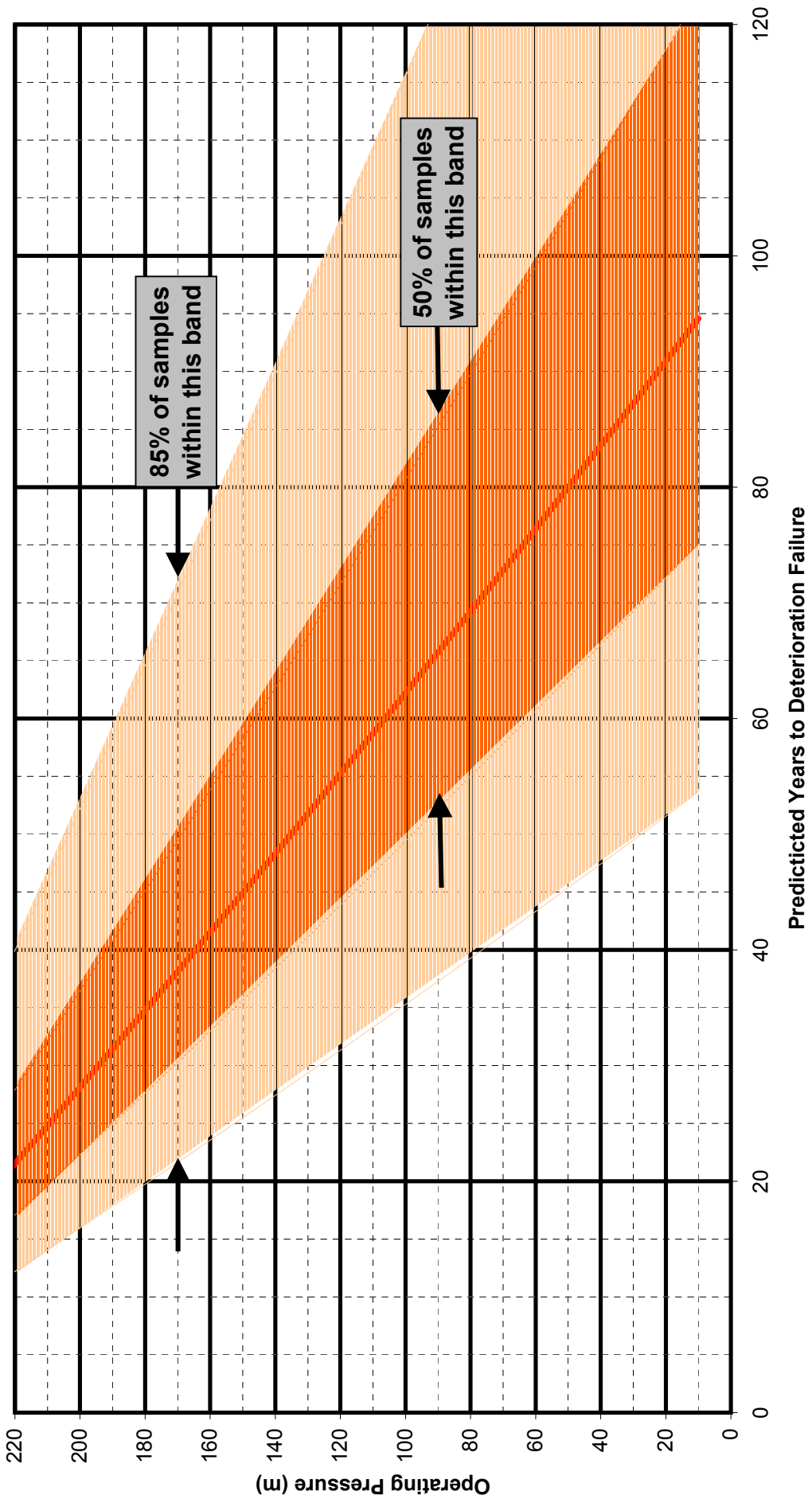



Lifetime Prediction Chart Calculations (300mm)

Pipe Class	Average Det'n Rate (mm/yr)	Average Wt (mm)	Standard Min Wt (mm)	Standard OD (mm)
300mm A	0.2269	0.0	14.5	334
300mm B	0.2269	0.0	17.3	334
300mm C	0.2269	0.0	25.4	345
300mm D	0.2269	0.0	33.0	345

Working Pressure (m)	Working Pressure + Surge (MPa)	Theoretical Min Wt (mm) Classes A & B		Det'n Causing Failure (mm)		Predicted Lifetime	
		300mm A	300mm B	300mm A	300mm B	300mm A	300mm B
10	0.15	0.98	17.32	14.52	64	64	145
20	0.29	1.95	16.35	13.55	60	60	141
30	0.44	2.92	15.38	12.58	55	55	137
40	0.59	3.88	14.42	11.62	51	51	132
50	0.73	4.83	13.47	10.67	47	47	128
60	0.88	5.78	12.52	9.72	43	43	124
70	1.03	6.73	11.57	8.77	39	39	119
80	1.17	7.67	10.63	7.83	35	35	115
90	1.32	8.60	9.70	6.90	30	30	111
100	1.47	9.53	8.77	5.97	26	26	106
110	1.62	10.45	7.85	5.05	22	22	102
120	1.76	11.37	6.93	4.13	18	18	98
130	1.91	12.28	6.02	3.22	14	14	94
140	2.06	13.19	5.11	2.31	10	10	90
150	2.20	14.09	4.21	1.41	6	6	86
160	2.35	14.99	3.31	0.51	1	1	82
170	2.50	15.88	2.42	0.00	0	0	78
180	2.64	16.77	1.53	0.00	0	0	74
190	2.79	17.65	0.65	0.00	0	0	69
200	2.94	18.53	-0.23	0.00	0	0	65
210	3.08	19.40	-1.10	0.00	0	0	62
220	3.23	20.27	-1.97	0.00	0	0	58
230	3.38	21.13	-2.83	0.00	0	0	54



Lifetime Prediction Chart Showing Predicted Years to Failure
(based on standard minimum wall thickness + 1 mm and average deterioration rate)

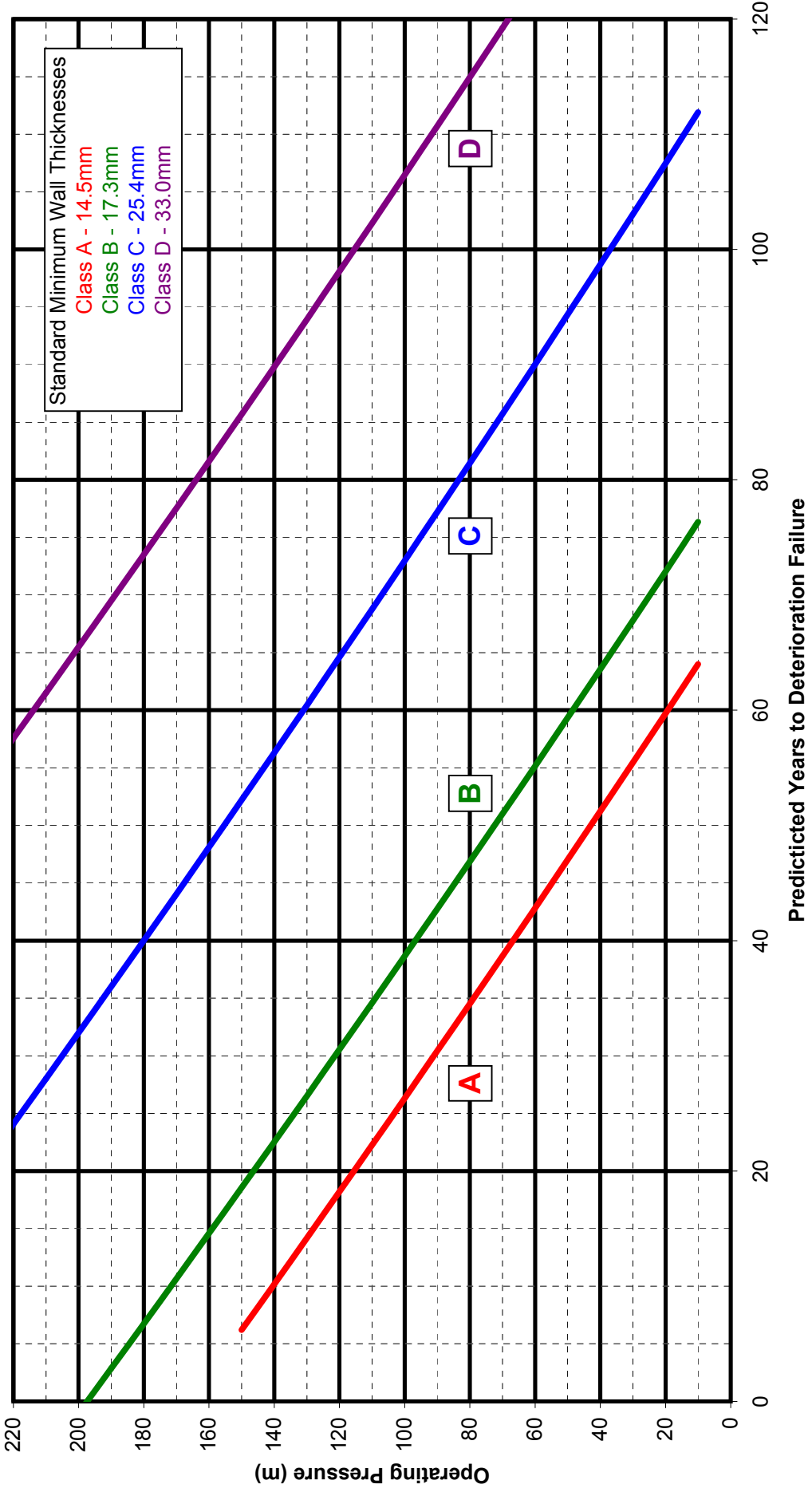



Variable Detn Chart Calculations (300mm)

Pipe Class	Average WT (mm)	Standard Min Wt (mm)	Standard OD (mm)	Rates of Deterioration (mm/yr)										
300mm C	0.0	25.4	345	<table style="width: 100%; border-collapse: collapse;"> <tr> <td style="width: 50%;">85% (Upper)</td> <td style="width: 50%;">0.4000</td> </tr> <tr> <td>50% (Upper)</td> <td>0.2857</td> </tr> <tr> <td>Average Rate</td> <td>0.2269</td> </tr> <tr> <td>50% (Lower)</td> <td>0.1750</td> </tr> <tr> <td>85% (Lower)</td> <td>0.1222</td> </tr> </table>	85% (Upper)	0.4000	50% (Upper)	0.2857	Average Rate	0.2269	50% (Lower)	0.1750	85% (Lower)	0.1222
85% (Upper)	0.4000													
50% (Upper)	0.2857													
Average Rate	0.2269													
50% (Lower)	0.1750													
85% (Lower)	0.1222													
The Standard Minimum Wall Thickness + 1 mm Will be Used for Lifetime Calculations														

Working Pressure (m)	Working Pressure + Surge (MPa)	Theoretical Min Wt (mm)	Det'n Causing Failure (mm)	Predicted Lifetimes				
				85% (Upper)	50% (Upper)	Average Rate	50% (Lower)	85% (Lower)
10	0.15	1.01	25.39	63	89	112	145	208
20	0.29	2.01	24.39	61	85	107	139	200
30	0.44	3.01	23.39	58	82	103	134	191
40	0.59	4.01	22.39	56	78	99	128	183
50	0.73	4.99	21.41	54	75	94	122	175
60	0.88	5.97	20.43	51	71	90	117	167
70	1.03	6.95	19.45	49	68	86	111	159
80	1.17	7.92	18.48	46	65	81	106	151
90	1.32	8.88	17.52	44	61	77	100	143
100	1.47	9.84	16.56	41	58	73	95	135
110	1.62	10.80	15.60	39	55	69	89	128
120	1.76	11.74	14.66	37	51	65	84	120
130	1.91	12.69	13.71	34	48	60	78	112
140	2.06	13.62	12.78	32	45	56	73	105
150	2.20	14.56	11.84	30	41	52	68	97
160	2.35	15.48	10.92	27	38	48	62	89
170	2.50	16.40	10.00	25	35	44	57	82
180	2.64	17.32	9.08	23	32	40	52	74
190	2.79	18.23	8.17	20	29	36	47	67
200	2.94	19.14	7.26	18	25	32	41	59
210	3.08	20.04	6.36	16	22	28	36	52
220	3.23	20.94	5.46	14	19	24	31	45
230	3.38	21.83	4.57	11	16	20	26	37



Lifetime Prediction Chart Showing Range of Predicted Years to Failure
(based on standard minimum wall thickness + 1 mm)

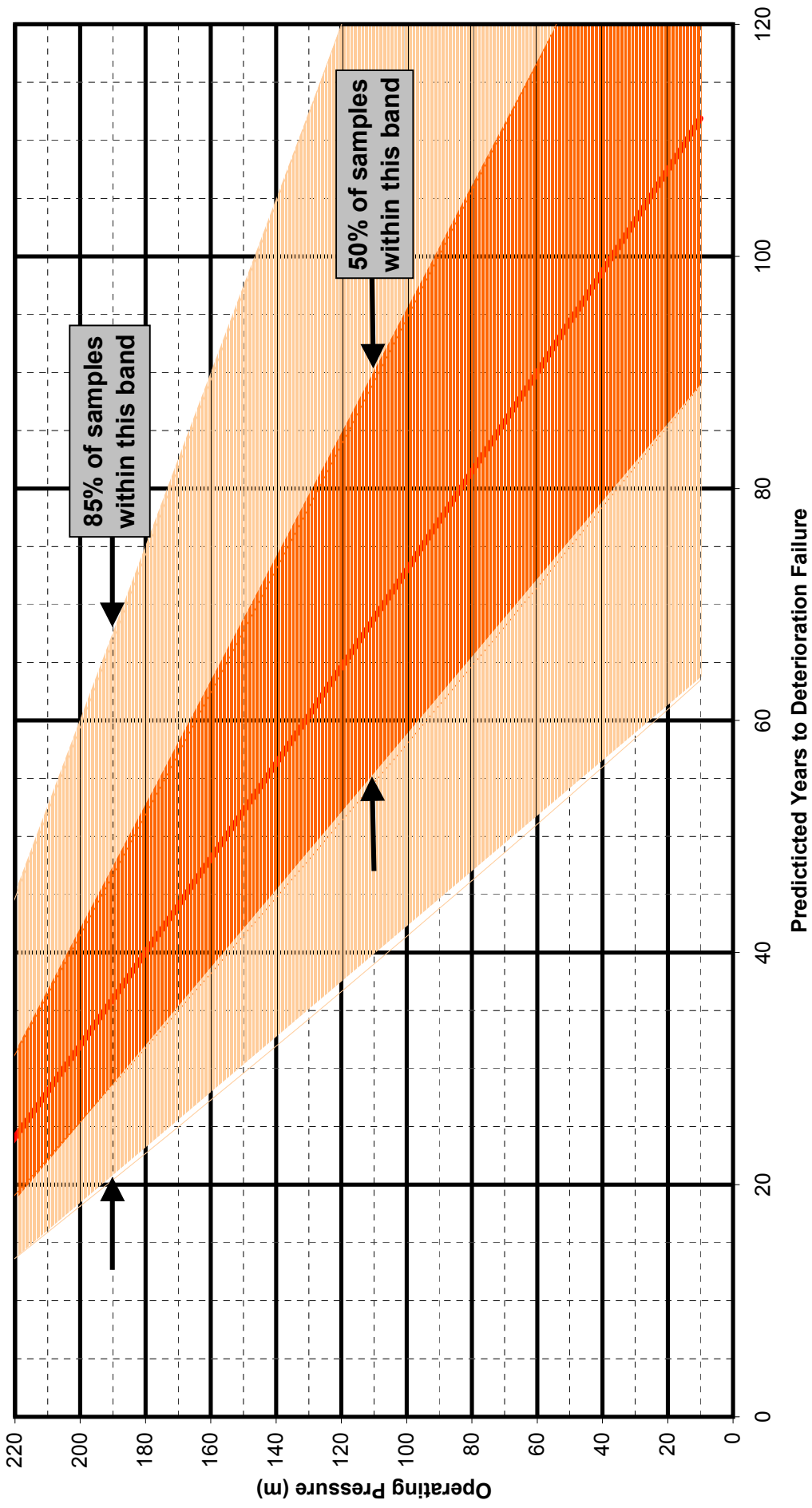



Lifetime Prediction Chart Calculations (375mm)

Pipe Class	Average Det'n Rate (mm/yr)	Average Wt (mm)	Standard Min Wt (mm)	Standard OD (mm)
375mm A	0.0		16.0	414
375mm B	0.0		21.3	414
375mm C	0.0		31.5	426

Working Pressure (m)	Working Pressure + Surge (MPa)	Theoretical Min Wt (mm) Classes A & B	375mm A		375mm B		375mm C	
			Det'n Causing Failure (mm)	Predicted Lifetime	Det'n Causing Failure (mm)	Predicted Lifetime	Det'n Causing Failure (mm)	Predicted Lifetime
10	0.15	1.21	15.79	70	21.09	93	31.25	138
20	0.29	2.42	14.58	64	19.88	88	30.01	132
30	0.44	3.62	13.38	59	18.68	82	28.78	127
40	0.59	4.81	12.19	54	17.49	77	27.55	121
50	0.73	5.99	11.01	49	16.31	72	26.34	116
60	0.88	7.17	9.83	43	15.13	67	25.12	111
70	1.03	8.34	8.66	38	13.96	62	23.92	105
80	1.17	9.50	7.50	33	12.80	56	22.72	100
90	1.32	10.66	6.34	28	11.64	51	21.53	95
100	1.47	11.81	5.19	23	10.49	46	20.35	90
110	1.62	12.96	4.04	18	9.34	41	19.17	84
120	1.76	14.09	2.91	13	8.21	36	18.00	79
130	1.91	15.22	1.78	8	7.08	31	16.83	74
140	2.06	16.35	0.65	3	5.95	26	15.68	69
150	2.20	17.47	-0.47	-2	4.83	21	14.53	64
160	2.35	18.58			3.72	16	13.38	59
170	2.50	19.69			2.61	12	12.24	54
180	2.64	20.79			1.51	7	11.11	49
190	2.79	21.88			0.42	2	9.99	44
200	2.94	22.97			0.67	3	8.87	39
210	3.08	24.05			-1.75	-8	7.75	34
220	3.23	25.12			-2.82	-12	6.65	29
230	3.38	26.19			-3.89	-17	5.55	24



Lifetime Prediction Chart Showing Predicted Years to Failure
(based on standard minimum wall thickness + 1mm and average deterioration rate)

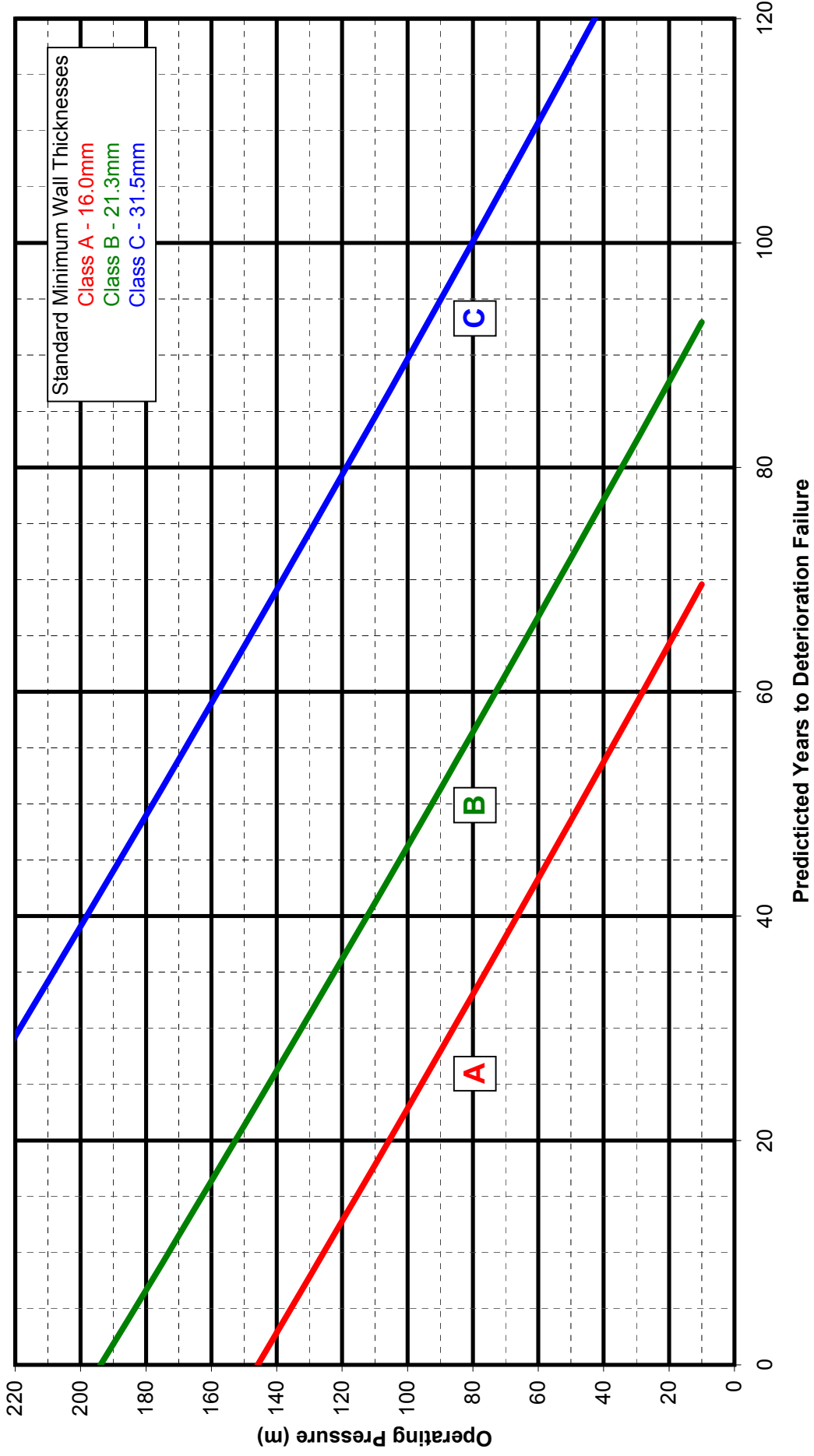



Variable Detn Chart Calculations (375mm)

Pipe Class	Average WT (mm)	Standard Min Wt (mm)	Standard OD (mm)	Rates of Deterioration (mm/yr)										
375mm C	0.0	31.5	426	<table style="width: 100%; border-collapse: collapse;"> <tr> <td style="width: 50%;">85% (Upper)</td> <td style="width: 50%;">0.4000</td> </tr> <tr> <td>50% (Upper)</td> <td>0.2857</td> </tr> <tr> <td>Average Rate</td> <td>0.2269</td> </tr> <tr> <td>50% (Lower)</td> <td>0.1750</td> </tr> <tr> <td>85% (Lower)</td> <td>0.1222</td> </tr> </table>	85% (Upper)	0.4000	50% (Upper)	0.2857	Average Rate	0.2269	50% (Lower)	0.1750	85% (Lower)	0.1222
85% (Upper)	0.4000													
50% (Upper)	0.2857													
Average Rate	0.2269													
50% (Lower)	0.1750													
85% (Lower)	0.1222													
The Standard Minimum Wall Thickness + 1mm Will be Used for Lifetime Calculations														

Working Pressure (m)	Working Pressure + Surge (MPa)	Theoretical Min Wt (mm)	Det'n Causing Failure (mm)	Predicted Lifetimes				
				85% (Upper)	50% (Upper)	Average Rate	50% (Lower)	85% (Lower)
10	0.15	1.25	31.25	78	109	138	179	256
20	0.29	2.49	30.01	75	105	132	172	246
30	0.44	3.72	28.78	72	101	127	164	236
40	0.59	4.95	27.55	69	96	121	157	225
50	0.73	6.16	26.34	66	92	116	150	216
60	0.88	7.38	25.12	63	88	111	144	206
70	1.03	8.58	23.92	60	84	105	137	196
80	1.17	9.78	22.72	57	80	100	130	186
90	1.32	10.97	21.53	54	75	95	123	176
100	1.47	12.15	20.35	51	71	90	116	167
110	1.62	13.33	19.17	48	67	84	110	157
120	1.76	14.50	18.00	45	63	79	103	147
130	1.91	15.67	16.83	42	59	74	96	138
140	2.06	16.82	15.68	39	55	69	90	128
150	2.20	17.97	14.53	36	51	64	83	119
160	2.35	19.12	13.38	33	47	59	76	110
170	2.50	20.26	12.24	31	43	54	70	100
180	2.64	21.39	11.11	28	39	49	63	91
190	2.79	22.51	9.99	25	35	44	57	82
200	2.94	23.63	8.87	22	31	39	51	73
210	3.08	24.75	7.75	19	27	34	44	63
220	3.23	25.85	6.65	17	23	29	38	54
230	3.38	26.95	5.55	14	19	24	32	45



Lifetime Prediction Chart Showing Range of Predicted Years to Failure
(based on standard minimum wall thickness + 1mm)

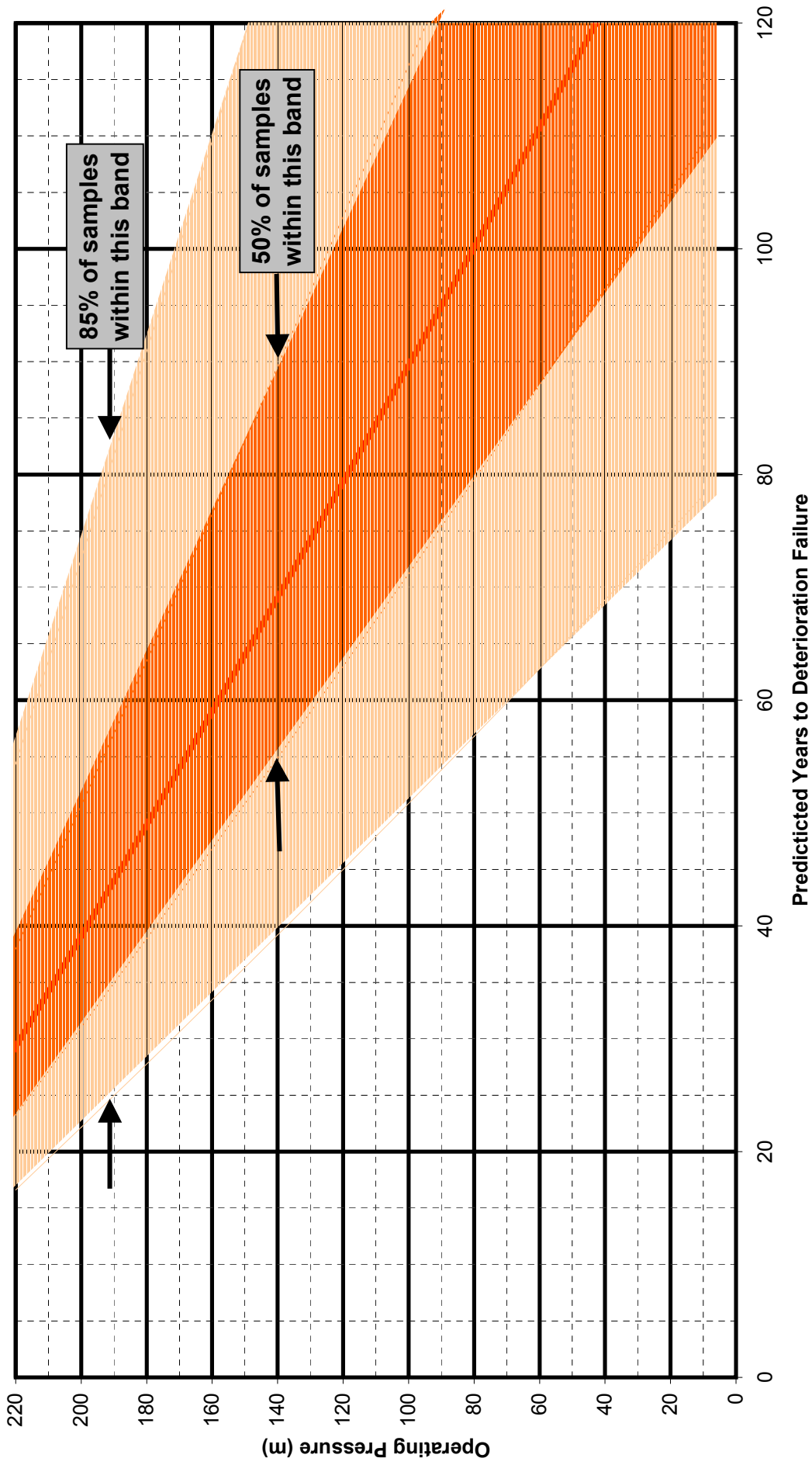



Working Database and Model Revision Status

Last Revision: **21/05/2001**

Today's Date: **13/09/2001**

Working Version is Current and Using the
Following Deterioration Relationship

Total Detn = 0.2269 x Sample Age

Surge Pressure = 1.5 x Operating Pressure



Local Authority	Location Description	City/Town	Pipe DN (mm)	Mean Pipe OD (mm)	Min. Pipe Wall Thickness (mm)	Pipe Specific Gravity	Working Pressure (m)	Max. External Det'n (mm)	Max. Internal Det'n (mm)	Total Det'n (mm)	Water Absorp. (%)	Bench Burst Press. (m)	Average Ext. Barcol Hardness	Average Int. Barcol Hardness	Year of Installation	Year of Appraisal	Sample Age
Example 1	Street 1	Town 1	100	127.0	17.7	1.98	58	2.0	1.0	3.0	7.9	826	20	30	1961	1999	38
Example 2	Street 2	Town 2	100	124.1	11.0	1.56	47	3.0	3.5	6.5	24.6	215	40	0	1960	1999	39
New Result 1	Location Description	City/Town	DN	OD	Wt	SG	Pressure	Ext Detn	Int Detn	#VALUE!	WA	BBP	Ext BH	Int BH	Installed	Appraised	#VALUE!
New Result 2	Location Description	City/Town	DN	OD	Wt	SG	Pressure	Ext Detn	Int Detn	#VALUE!	WA	BBP	Ext BH	Int BH	Installed	Appraised	#VALUE!
New Result 3	Location Description	City/Town	DN	OD	Wt	SG	Pressure	Ext Detn	Int Detn	#VALUE!	WA	BBP	Ext BH	Int BH	Installed	Appraised	#VALUE!
New Result 4	Location Description	City/Town	DN	OD	Wt	SG	Pressure	Ext Detn	Int Detn	#VALUE!	WA	BBP	Ext BH	Int BH	Installed	Appraised	#VALUE!
New Result 5	Location Description	City/Town	DN	OD	Wt	SG	Pressure	Ext Detn	Int Detn	#VALUE!	WA	BBP	Ext BH	Int BH	Installed	Appraised	#VALUE!
New Result 6	Location Description	City/Town	DN	OD	Wt	SG	Pressure	Ext Detn	Int Detn	#VALUE!	WA	BBP	Ext BH	Int BH	Installed	Appraised	#VALUE!
New Result 7	Location Description	City/Town	DN	OD	Wt	SG	Pressure	Ext Detn	Int Detn	#VALUE!	WA	BBP	Ext BH	Int BH	Installed	Appraised	#VALUE!
New Result 8	Location Description	City/Town	DN	OD	Wt	SG	Pressure	Ext Detn	Int Detn	#VALUE!	WA	BBP	Ext BH	Int BH	Installed	Appraised	#VALUE!
New Result 9	Location Description	City/Town	DN	OD	Wt	SG	Pressure	Ext Detn	Int Detn	#VALUE!	WA	BBP	Ext BH	Int BH	Installed	Appraised	#VALUE!
New Result 10	Location Description	City/Town	DN	OD	Wt	SG	Pressure	Ext Detn	Int Detn	#VALUE!	WA	BBP	Ext BH	Int BH	Installed	Appraised	#VALUE!

NOTE

Refer Section 2 - National AC Watermain Database and Lifetime Prediction Model - Development and Application, page 2.5, for using the Working Database and Model
Copy spreadsheets from CD to utilise the Working Database and Model



Lifetime Prediction Model

Input from National Data Base										Calculations Based on Sample Data				Deterioration Model Output			Lifetime Prediction Model Output	
Local Authority	Location Description	City/Town	Pipe DN (mm)	Mean Pipe OD (mm)	Min. Pipe Wall Thickness (mm)	Working Pressure (m)	Total Det'n (mm)	Year of Installation	Year of Appraisal	Sample Age (years)	Working Pressure + Surge (MPa)	Minimum Underdeteriorated Wt before failure (mm)	Total Det'n Causing Failure (mm)	Sample Det'n Rate (mm/year)	Modelled Det'n (mm)	Comparison with National Average	Estimated Pipe Life (years)	Estimated Year of First Det'n Failure
Example 1	Street 1	Town 1	100	127.0	17.7	58	3.0	1961	1999	38	0.85	2.1	15.6	0.079	8.6	-65%	100	2061
Example 2	Street 2	Town 2	100	124.1	11.0	47	6.5	1966	1999	39	0.89	1.7	9.3	0.167	8.8	-27%	56	2016
New Result 1	Location Description	City/Town	DN	OD	Wt	Pressure	#VALUE!	Installed	Appraised	#VALUE!	#VALUE!	#VALUE!	#VALUE!	#VALUE!	#VALUE!	#VALUE!	#VALUE!	#VALUE!
New Result 2	Location Description	City/Town	DN	OD	Wt	Pressure	#VALUE!	Installed	Appraised	#VALUE!	#VALUE!	#VALUE!	#VALUE!	#VALUE!	#VALUE!	#VALUE!	#VALUE!	#VALUE!
New Result 3	Location Description	City/Town	DN	OD	Wt	Pressure	#VALUE!	Installed	Appraised	#VALUE!	#VALUE!	#VALUE!	#VALUE!	#VALUE!	#VALUE!	#VALUE!	#VALUE!	#VALUE!
New Result 4	Location Description	City/Town	DN	OD	Wt	Pressure	#VALUE!	Installed	Appraised	#VALUE!	#VALUE!	#VALUE!	#VALUE!	#VALUE!	#VALUE!	#VALUE!	#VALUE!	#VALUE!
New Result 5	Location Description	City/Town	DN	OD	Wt	Pressure	#VALUE!	Installed	Appraised	#VALUE!	#VALUE!	#VALUE!	#VALUE!	#VALUE!	#VALUE!	#VALUE!	#VALUE!	#VALUE!
New Result 6	Location Description	City/Town	DN	OD	Wt	Pressure	#VALUE!	Installed	Appraised	#VALUE!	#VALUE!	#VALUE!	#VALUE!	#VALUE!	#VALUE!	#VALUE!	#VALUE!	#VALUE!
New Result 7	Location Description	City/Town	DN	OD	Wt	Pressure	#VALUE!	Installed	Appraised	#VALUE!	#VALUE!	#VALUE!	#VALUE!	#VALUE!	#VALUE!	#VALUE!	#VALUE!	#VALUE!
New Result 8	Location Description	City/Town	DN	OD	Wt	Pressure	#VALUE!	Installed	Appraised	#VALUE!	#VALUE!	#VALUE!	#VALUE!	#VALUE!	#VALUE!	#VALUE!	#VALUE!	#VALUE!
New Result 9	Location Description	City/Town	DN	OD	Wt	Pressure	#VALUE!	Installed	Appraised	#VALUE!	#VALUE!	#VALUE!	#VALUE!	#VALUE!	#VALUE!	#VALUE!	#VALUE!	#VALUE!
New Result 10	Location Description	City/Town	DN	OD	Wt	Pressure	#VALUE!	Installed	Appraised	#VALUE!	#VALUE!	#VALUE!	#VALUE!	#VALUE!	#VALUE!	#VALUE!	#VALUE!	#VALUE!

NOTE

Refer Section 2 - National AC Watermain Database and Lifetime Prediction Model - Development and Application, page 2.5, for using the Working Database and Model Copy spreadsheets from CD to utilise the Working Database and Model

CONDITION RATING OF ASBESTOS CEMENT WATERMAINS

(FUTURE)

SECTION 5



PIPE CONDITION GRADING

Development and Application

SECTION 5

Contents

1. Introduction	
2. Condition Grading	5
2.1 General Description	5-1
2.2 Grading Based on Predicted Remaining Lifetime	5-2
2.3 Grading Based on Minimum Remaining Undeteriorated Wall Thickness	5-4
2.4 Comments on the Two Methods	5-4
2.5 Predicting Remaining Lifetime from the Undeteriorated Wall Thickness.....	5-5
3 Wall Charts	5
3.1 Condition Grading Minimum Remaining Undeteriorated Wall Method	5-6
- 50 DN AC Pipe	5-6
- 80 DN AC Pipe	5-7
- 100 DN AC Pipe	5-8
- 150 DN AC Pipe	5-9
- 200 DN AC Pipe	5-10
- 225 DN AC Pipe	5-11
- 250 DN AC Pipe	5-12
- 300 DN AC Pipe	5-13
- 375 DN AC Pipe	5-14
3.2 Condition Grading Remaining Life Method	5-15
- 50 DN AC Pipe	5-15
- 80 DN AC Pipe	5-16
- 100 AC DN Pipe	5-17
- 150 DN AC Pipe	5-18
- 200 DN AC Pipe	5-19
- 225 DN AC Pipe	5-20
- 250 DN AC Pipe	5-21
- 300 DN AC Pipe	5-22
- 375 DN AC Pipe	5-23

1 Introduction

This document covers the development and application of the pipe condition grading section of the manual. Consistent condition rating for asbestos cement (AC) pipes is possible using the lifetime prediction model and the deterioration rates found during the development of the lifetime prediction model.

Two techniques have been developed to allow the condition of the AC pipes in a network to be graded. These techniques may also be used for sewage or storm water rising mains.

Two sets of charts (one for each of the AC pipe diameters from DN 50 to DN 375) have been produced and these are used to arrive at a condition grading for a particular pipe sample. This grading may then be applied to other pipes within a network that are of similar age and condition. The charts take account of the operating pressure, as this has a bearing on the remaining lifetime.

2 Condition Grading

2.1 General Description

Two methods of deriving the condition grading for AC pipes are detailed. The first is based on the calculated remaining lifetime (as determined using the lifetime prediction model) and the second uses the measured minimum thickness of undeteriorated AC material in the pipe wall.

Using the calculated remaining lifetime method will provide a more reliable condition grading as the rate of deterioration is taken into account. The remaining undeteriorated wall method makes use of the national average deterioration rate in the grading process and as such may under or over estimate the pipe condition, depending on whether the pipe is deteriorating at a faster or slower rate than the nation average.

The grading system provides for 5 grades as per the New Zealand Infrastructure Asset Grading Guidelines. The grading is related to the probable remaining life of the pipeline so that there is no need for a qualitative judgement regarding the pipe condition.

The Condition grades used for AC pipes and their meanings are given in TABLE 2-1.

TABLE 2-1 WATER MAINS, SEWAGE & STORMWATER PUMPING MAINS	
Condition Grade	General Meaning
1	Very Good. At least 75% of the life of a new AC pipe remaining.
2	Good At least 50% of the life of a new AC pipe remaining
3	Moderate At least 25% of the life of a new AC pipe remaining
4	Poor Less than 25% of the life of a new AC pipe remaining
5	Very Poor Imminent failure predicted. Deterioration failures have probably already occurred

The condition grades given in TABLE 2-1 are related to the predicted lifetime of new AC pipes of the pressure classes given in TABLE 2-2. These pressure classes have been chosen as the most appropriate and commonly used for municipal reticulation networks.

Pipe Diameter	Pressure Class
50 (2" or 2.25")	Class AF
80 (3")	Class CD
100 (4")	Class CD
150 (6")	Class C
200 (8")	Class C
225 (9")	Class C
250 (10")	Class C
300 (12")	Class C
375 (15")	Class C

When using the Remaining Undeteriorated Wall Thickness method it is possible to make an estimate of the remaining lifetime for a pipe sample. This process is described more fully in section 2.5.

It would be possible to develop specific grading charts for each Water supply Authority, provided sufficient sampling results are available to establish a specific trend (that may be different to the national average).

2.2 Grading Based on Predicted Remaining Lifetime

The assessment procedure is:

- 1 Take pipe sample)
- 2 Confirm installation date) These items are done as
- 3 Measure pipe OD and minimum wall thickness) per the National Testing
- 4 Determine peak operating pressure (Ignore surges)) Standard for AC pipes.
- 5 Cut sample and measure deterioration (phenolphthalein))
- 6 Use working model to predict remaining lifetime
- 7 Take remaining lifetime prediction & pressure & plot on chart
- 8 Read off the condition rating (1-5)

FIGURE 2-1 shows an example of the condition grading chart based on the predicted remaining life method for DN 100 (4") AC pipe. Four examples of typical DN 100 AC pipes taken from the National Database have been plotted on FIGURE 2-1.

The relevant pipe sample details plotted on FIGURE 2-1 are shown in TABLE 2-3:

TABLE 2-3 DETAILS OF THE 3 PIPE SAMPLES PLOTTED ON FIGURE 2-1							
Number	Installation Date	Sample Date	Pipe OD (mm)	Min. Wall (mm)	Max. Det'n (mm)	Operating Pressure (m)	Predicted Rem. Life (yrs)
1	1960	1999	128.0	18.2	8.0	48	41
2	1982	1998	124.1	13.7	6.2	110	9
3	1956	1999	119.1	14.1	12.5	50	0
4	1954	1992	121.9	13.0	6.7	70	22

FIGURE 2-1 EXAMPLE OF PREDICTED REMAINING LIFE METHOD OF GRADING

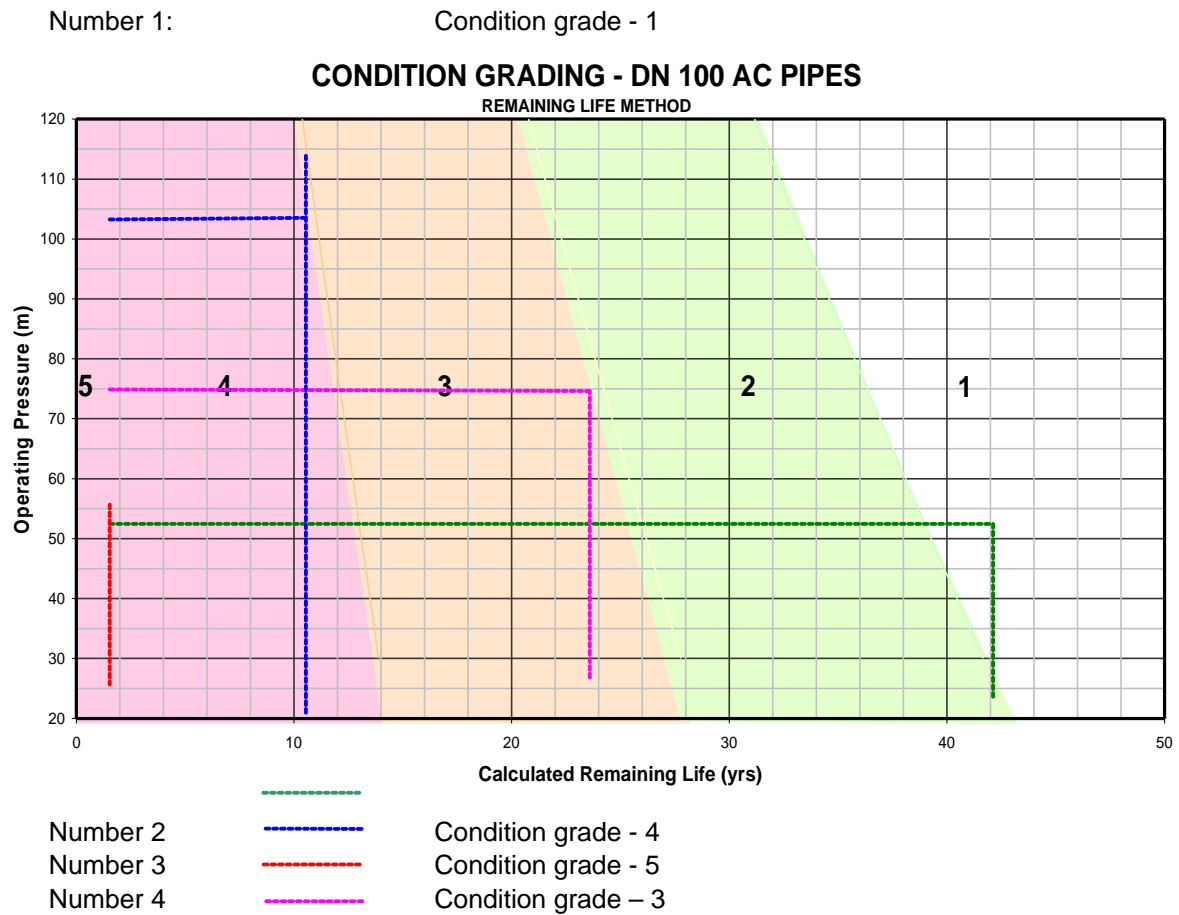

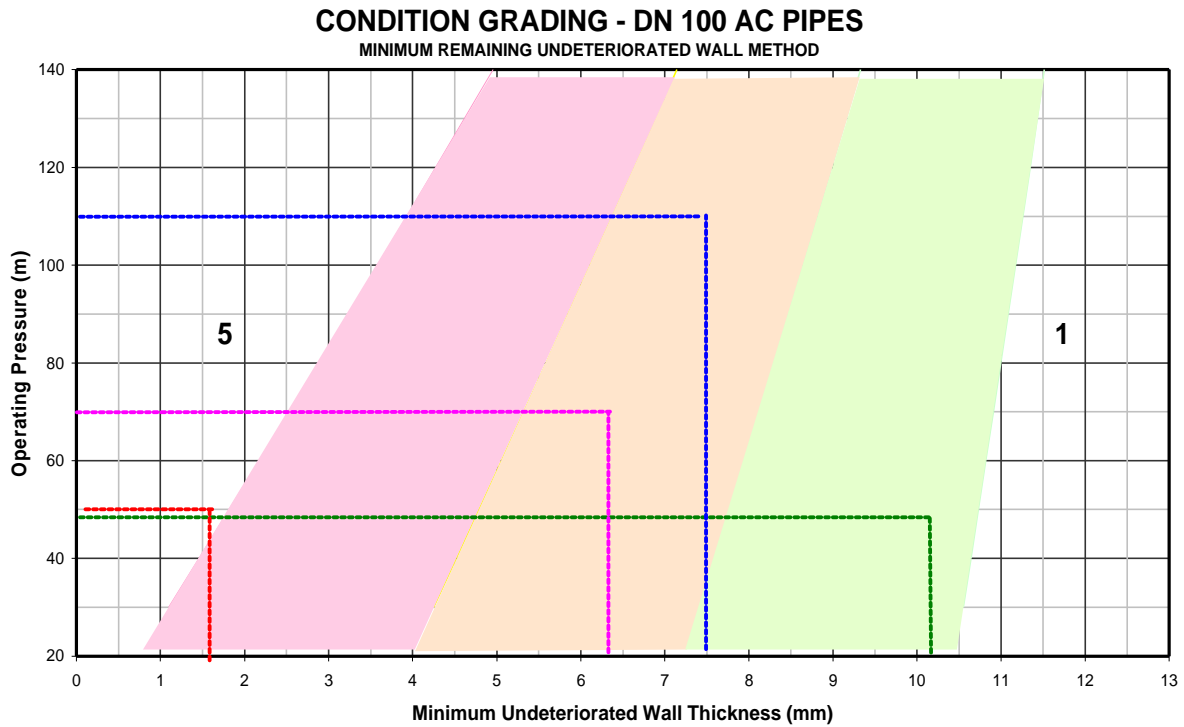

2.3 Grading Based on Minimum Remaining Undeteriorated Wall Thickness

The assessment procedure is:

- 1 Take pipe sample
- 2 Determine peak operating pressure (Ignore surges)
- 3 Cut sample and measure minimum undeteriorated wall thickness (phenolphthalein)
- 4 Plot the minimum remaining undeteriorated wall thickness on the chart
- 5 Read off the condition rating (1-5)

FIGURE 2-2 shows an example of the condition grading chart based on the measured remaining wall method for DN 100 (4”) AC pipe. The same examples of DN 100 AC pipes used on FIGURE 2-1 have been plotted on FIGURE 2-2.

The relevant pipe details are shown in TABLE 2-4:

TABLE 2-4 DETAILS OF THE 3 PIPE SAMPLES PLOTTED ON FIGURE 2-2						
Number	Installation Date	Sample Date	Min. Wall (mm)	Max. Det'n (mm)	Min. Remaining Wall	Operating Pressure (m)
1	1960	1999	18.2	8.0	10.2	48
2	1982	1998	13.7	6.2	7.5	110
3	1956	1999	14.1	12.5	1.6	50
4	1954	1992	13.0	6.7	6.3	70

FIGURE 2-2 EXAMPLE - MINIMUM UNDETERIORATED WALL METHOD OF GRADING

Number 1: Condition grade - 2

Number 2	Condition grade - 3
Number 3	Condition grade – 5
Number 4	Condition grade – 3

2.4 Comments on the Two Methods

The four examples above illustrate the potential for differences in condition grading that exist between the two methods. While the Minimum Undeteriorated Wall method involves a little less work, the end result may not be as reliable as the Predicted Remaining Life method. TABLE 2-5 shows the comparison between the two methods with a brief explanation.

Number	Condition Grading		Comments
	Remaining Life	Undeteriorated Wall	
1	1	2	Pipe deteriorating at 10% less than national average. The undeteriorated wall method under estimates grading.
2	4	3	Pipe deteriorating at 70% faster than the national average and undeteriorated wall method over estimates grading.
3	5	5	Pipe is at end of life and both methods show this.
4	3	3	Pipe is deteriorating at 20% less than national average. Both methods give grade 3, but the undeteriorated wall method under estimates the condition/remaining life.

2.5 Predicting the Remaining Lifetime from the Undeteriorated Wall Thickness

When using the Remaining undeteriorated wall thickness method it is possible to make an *estimate* of the remaining lifetime for a pipe sample. This is done by determining the condition grade as described in section 2.3 and then transferring this result to the “Remaining Life” chart. As discussed above, the rate of deterioration will have an effect on the results obtained and can make a significant difference.

It is necessary to obtain a similar amount of information on the pipe for both assessment methods and the use of the lifetime prediction model is recommended to determine the predicted remaining life.

CONDITION RATING OF ASBESTOS CEMENT WATERMAINS

(TO BE DEVELOPED IN 2002)

