

# **Optimisation of Small Drinking-water Treatment Systems**

Resources for the Drinking-water  
Assistance Programme

Ministry of Health. 2007. *Optimisation of Small Drinking-water Treatment Systems: Resources for the Drinking-water Assistance Programme*. Wellington: Ministry of Health.

Published in September 2007 by the  
Ministry of Health  
PO Box 5013, Wellington, New Zealand

ISBN 978-0-478-19144-8 (print)  
ISBN 978-0-478-19147-9 (online)  
HP 4411

This document is available on the Ministry of Health's website:  
<http://www.moh.govt.nz>



MANATŪ HAUORA

# Contents

1	Introduction	1
2	Methods Used for Optimisation	2
2.1	Useful steps for process optimisation	2
2.2	Identification of critical points	6
2.3	Skills and support	6
2.4	Risk management	6
3	Setting Up Maintenance and Performance Checking	8
4	Improving the Source	10
4.1	Minimisation	10
4.2	River intakes	10
4.3	Infiltration galleries	12
4.4	Bores	14
4.5	Springs	18
5	Improving Pre-treatment	21
5.1	Roughing filters	21
5.2	Raw water storage	22
6	Improving Filtration (Media and Cartridge Type)	25
6.1	Cartridge filters	25
6.2	Media filters	27
7	Improving Disinfection	32
7.1	Chlorination	32
7.2	Ultra violet light	36
8	Improving Treated Water Storage	39
9	Places to Get Information	41
10	Worked Examples	42

## List of Tables

Table 1:	Problems and solutions related to maintaining river intakes	12
Table 2:	Problems and solutions related to maintaining infiltration galleries	14
Table 3:	Problems and solutions related to maintaining bores	17
Table 4:	Problems and solutions related to maintaining springs	20
Table 5:	Problems and solutions related to maintaining roughing filters	22
Table 6:	A comparison of untreated and treated water storage systems	23
Table 7:	Problems and solutions related to maintaining raw water storage	24
Table 8:	Problems and solutions related to maintaining cartridge filters	27
Table 9:	Problems and solutions related to maintaining media filters	30
Table 10:	Problems and solutions related to maintaining chlorination systems	35
Table 11:	Problems and solutions related to maintaining a UV disinfection system	38
Table 12:	Problems and solutions related to maintaining water storage systems	40
Table 13:	Sources of further information	41

## List of Figures

Figure 1:	Schematic diagram of a treatment process	1
Figure 2:	Process schematic diagram	3
Figure 3:	Trend of turbidity over time	4
Figure 4:	Common features of a river intake	10
Figure 5:	Infiltration gallery	12
Figure 6:	Typical bore	15
Figure 7:	Contamination of spring water	18
Figure 8a:	Disc filter	21
Figure 8b:	Horizontal flow gravel media roughing filter	21
Figure 9a:	Cartridge filter system	25
Figure 9b:	Used cartridge filters	25
Figure 10a:	Straining of particles	28
Figure 10b:	Attachment of small particles	28
Figure 11:	Rapid gravity filter	28
Figure 12:	Pressure filter	28
Figure 13:	Relationship between pH and the form that chlorine takes in water	33
Figure 14:	UV disinfection system	36
Figure 15:	Groundwater from a simple bore water system (Scenario 1)	42
Figure 16:	Cartridge filter system (Scenario 2)	43
Figure 17:	UV disinfection unit (Scenario 3)	44

# 1 Introduction

This booklet provides information about the supply of safe drinking-water to small water supplies serving fewer than 5000 people.

The intention of optimisation is to achieve the most effective and efficient use of a water treatment plant – which includes getting the best out of each piece of equipment that is part of the supply as well as operating and managing the supply in a way that produces the best quality of water possible.

Part of optimisation is to look at each piece of equipment and make sure it is working as well as it can. But, in addition to this concern with the contribution of individual parts of the plant, it is important to focus on the overall performance of the plant. This is because the performance of each part of the plant depends on the performance of the parts that come before it. For example, the performance of the ultra violet (UV) disinfection unit in Figure 1 will depend on the turbidity level of the water leaving the cartridge filter. In turn, the performance of the cartridge filter will be dependent on the performance of the multimedia filter system. All parts of the system will perform better if they are run for long periods of time, or even continuously, rather than being stopped and started.

**Figure 1:** Schematic diagram of a treatment process

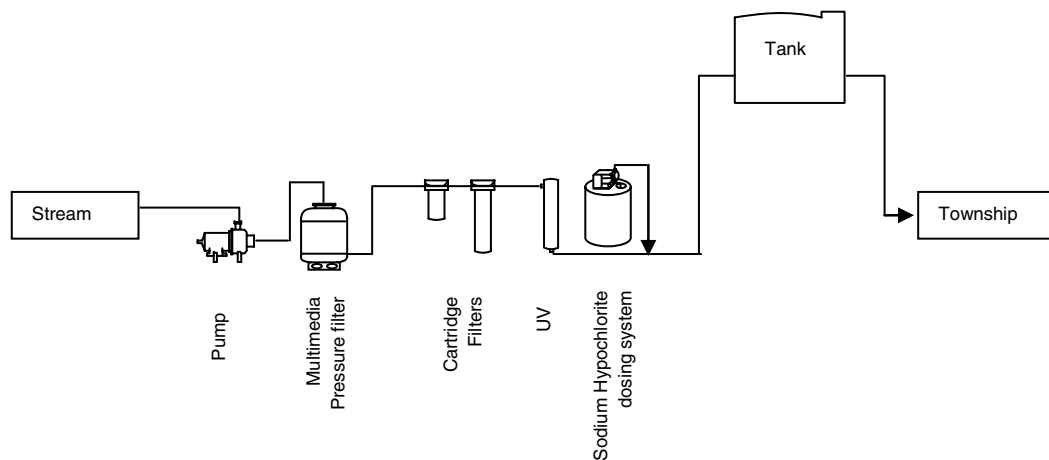

Water suppliers are encouraged to try optimising processes to improve performance, provided the consequences of the changes do not result in the delivery of poor quality water to the consumer.

There are also some less obvious aspects related to getting consistent operation out of a plant, ranging from planning for unusual events such as natural disasters, to simpler issues like coping with the operator being away. Another aspect that is often overlooked is the operator's own knowledge. In some situations the operator can be 'optimised' with some extra training!

The emphasis of this document is on issues that affect the safety of the consumer rather than on protecting assets and minimising costs.

## **2 Methods Used for Optimisation**

Optimisation aims to improve the quality or quantity of water that is delivered from a water supply. It can be achieved most easily if a logical and consistent approach is adopted.

### **2.1 Useful steps for process optimisation**

The first step is to systematically gather information about the system and how it performs. Examples of useful information are as follows.

#### **1. A schematic drawing of how the plant is designed**

Before making any changes to the system or how it is used, it is important to properly understand the layout and interrelationships among all of the pieces of equipment. A schematic drawing of the plant can help to work out the way the treatment process works (see Figure 2). It should include the method of collecting information that provides evidence of how well it is operating. Some plant problems are directly related to the design, some are related to operation.

The diagram needs to show the treatment steps in order, where the flow goes and where measurements are taken.

For each process the objectives, such as quality, flow, pressure and level, need to be listed. For example, for a cartridge filter, which would normally have a turbidity target, measurements may be taken for turbidity, upstream pressure and downstream pressure. The turbidity could be measured by taking an onsite grab sample, a sample for laboratory analysis or using a permanently installed meter.

Each measurement place should be included on the diagram.

**Figure 2:** Process schematic diagram

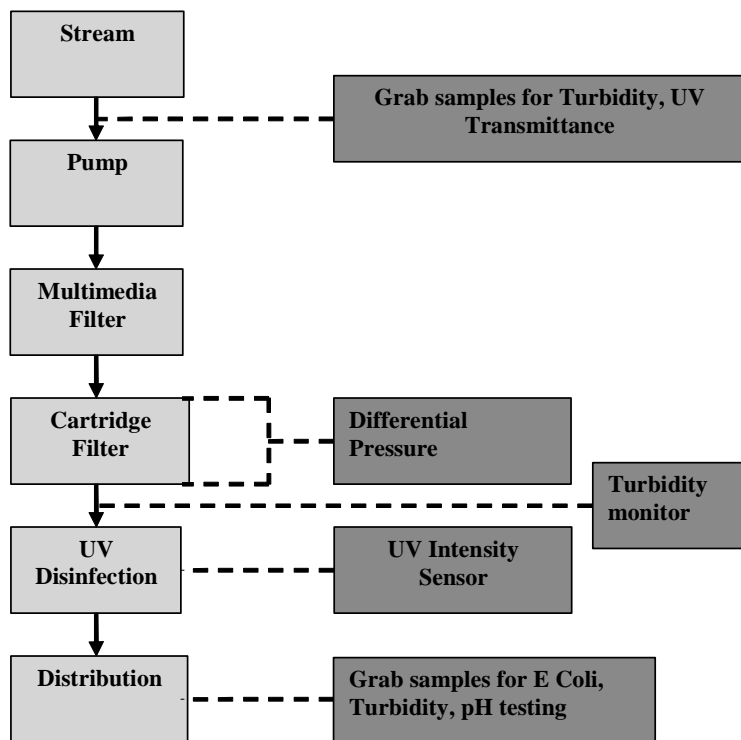

## 2. Visual observations

It is important to observe how the plant performs in different conditions. Sometimes it is obvious that things are not running as well as they should be. The best way to observe plant operation is to follow the same route the water takes. Start with the raw water intake and go through the plant to the treated water reservoir. Observe the operation of each unit, noting obvious problems. Samples can be taken to check the performance of each stage of treatment.

Over time, the observations will show when things go wrong and what the causes are.

## 3. Plant operating records

Daily records of operational settings and activities are also useful in diagnosing the causes of performance problems. In addition, keeping a record of operations and maintenance can assist in having a reminder that something needs doing, especially if it is something that happens only infrequently.

Here are some areas that the records should cover:

- water quality data
- water production / demand
- changes to plant operation
- consumption of power and or other resources
- timing of maintenance.

The records should include who did the work, why and when they did it and what they did. It is useful to include the targets that need to be achieved alongside the values that are being recorded.

#### 4. Evaluation

Each part of the plant operation needs to be looked at in terms of when it happens and what effects it has. Ideally data would be gathered over a long period. It may also be useful to collect other information or take measurements over a shorter period.

If data (or a trend) can be shown on a graph, then changes in performance can be seen clearly and possibly related back to see what caused a problem. It is also helpful to draw related data on the same chart so that the relationships can be seen easily. For example, you might draw a graph of plant flow and filter turbidity over a day to see whether the flow is affecting the turbidity (see Figure 3).

**Figure 3:** Trend of turbidity over time

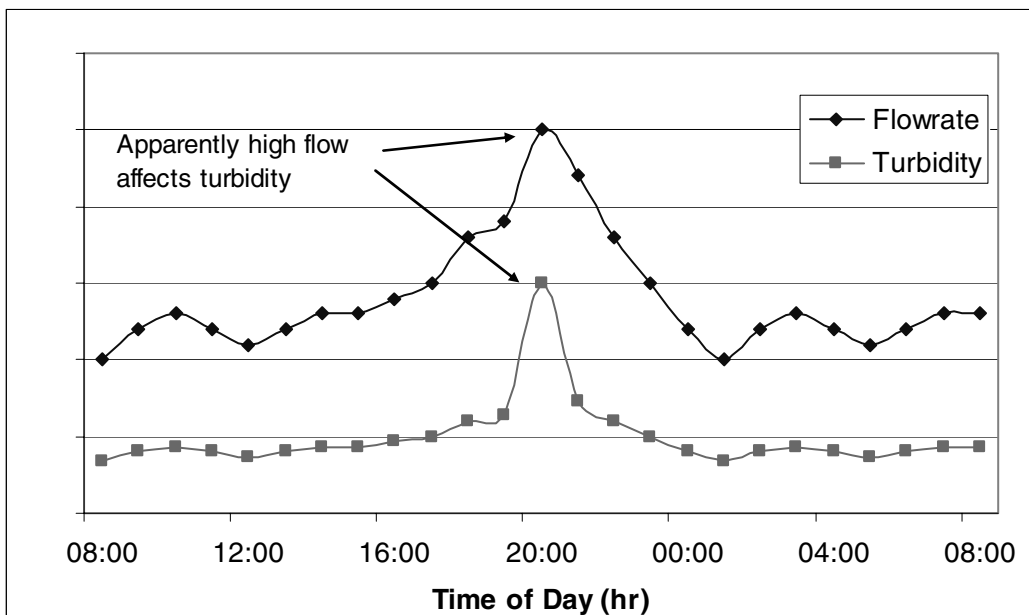

#### 5. Make adjustments to the plant

Once you have an idea of what affects plant or process performance, the areas in which there is potential to make improvements or adjustments will be clearer. It may be necessary to plan how to adjust the process to test a theory. If there is a risk to water quality, then the water used should be run to waste rather than put into supply.

The following is an example of information that might be recorded at a small water treatment plant where water is filtered through a multimedia filter and a cartridge filter, then disinfected with UV light. The choice of what to record and when depends on the particular circumstances including what risks apply to the water supply.

## Plant operating record example

This example of an operating record is based on the system shown in Figure 1, where water is pumped from a river through a multimedia pre-filter, cartridge filters, UV disinfection and chlorination prior to storage and distribution.

The records that are shown in Examples 1 and 2 below are given only as a general illustration of how they can look. Specific records will have to be designed for the particular needs of the water supply.

### Example 1: Plant operating records

Reading	Unit			
Date and time		12/5/08 0915	13/5/08 1030	14/5/08 0900
Rain gauge reading	mm	0	12	1
River level	M	1.2	2.5	1.8
Volume into plant (totaliser reading)	M <sup>3</sup>	105060	106991	108925
(Difference)		(1725)	(1931)	(1934)
Multimedia filter backwash time	time of day	0930	1100	1000
Pressure reading before cartridge filter	kPa	250	230	250
Pressure reading after cartridge filter	kPa	100	60 (replaced cartridge)	200
UV intensity meter		OK	OK	OK
Check lamps clean and operating		OK	Cleaned lamp	OK
Reservoir discharge chlorine sample	mg/l	0.5	0.5	0.4

### Example 2: Laboratory test results

Reading	Unit			
Date and time		12/5/08 0915	13/5/08 1030	14/5/08 0900
Raw water turbidity	NTU	0.5	50	18
Filtered water turbidity Control point = 0.8	NTU	0.3	0.8 Checked system pressure reading, cartridge was unloading	0.6
<i>E. coli</i> test	CFU/100 mL	0	0	0

## 2.2 Identification of critical points

When optimising a plant, it is helpful to pay close attention to the parts of the plant that have the most impact on performance. The most important areas are called **critical points**.

A critical point is a point in the treatment process at which, if the operators do their job well, the likelihood of good water quality is increased. Conversely, if a poor job is done at this point, there is a higher likelihood of poor water quality.

- To be a critical point there must be something that can be measured and for which acceptable limits can be set. A target should be set that will lead to action before there is an unacceptable deterioration in water quality.
- The critical point should be monitored sufficiently often to reveal any failures in a timely manner.
- There should be procedures in place to correct any deviation from the target value.

## 2.3 Skills and support

No plant can be operated at its optimum without a good operator who is available when needed. An operator should have the right support and training. They need to have delegated authority to get things done and back-up to cover for time off.

For example, support could come from someone operating another water supply nearby. It could be helpful to arrange regular meetings to form a relationship and share resources.

Operator training is important if a water supply is to improve. While training is available from formal courses, the benefits of informal collaboration with other operators should not be overlooked.

A vital part of the support of operators is creating manuals and documentation so that someone with no more than an overview of the process can pick up operation. Good documentation is important because sometimes the person who is picking up the water treatment role may normally have a different role (eg, as a teacher or an interested volunteer) and is faced with the task unexpectedly.

## 2.4 Risk management

The Ministry of Health promotes the process of risk management planning of public health risks to control the hazards to a water supply. This process is an important part of plant optimisation.

The **public health risk management plan** will have identified situations that have the potential to make the water unsafe or stop the flow of water. Such situations might be routine events like contamination of the source (eg, a landslide upstream of the intake), pump failure, power failure or a broken water main. They will also include uncommon events like backflow, natural disasters, chlorine gas leaks and fire.

Preventive measures will have been identified. They will outline how these problems will be managed around to prevent contamination when the event arises.

A **contingency plan** is a plan to be followed should the preventive measures fail to prevent a hazard. Issues that should be considered include public warnings, access to the plant site, back-up personnel, repairs to equipment and use of alternative equipment.

One of the hazards that can affect a water supply is vandalism. Sufficient security needs to be in place to deter a 'wayward child'. A determined adult is very difficult to protect against.

### 3 Setting Up Maintenance and Performance Checking

Plant maintenance and performance checking are very important if the plant is to operate reliably. Maintenance will extend the useful life of equipment and will help to avoid breakdowns and emergencies. Performance checks will demonstrate whether equipment is deteriorating before it becomes critical.

Routines for maintenance tasks should be planned in advance and described in procedures. The purpose of this process is to ensure that work is not forgotten and that there is a system to allow others to step in when needed. Worksheets can be used as a reminder to do the work and as a record after the work is completed.

Here are some rules of thumb for good plant maintenance.

- Keep everything clean, orderly and organised. This sets the scene for careful operation and pride in the supply. A water treatment plant should be viewed as a food factory that is producing 24 hours per day. A high standard of hygiene should be set for the water treatment plant.
- Develop a plan for plant operation and follow it. Of course the plan can be modified when needed.
- Follow an inspection and lubrication routine for each piece of equipment. Schedules and procedures should follow manufacturer's recommendations unless experience can demonstrate that they should be changed. Historically many problems have been due to misunderstanding or failing to follow these recommendations.
- Keep records of maintenance and repair for each piece of equipment. These records will show which items of equipment are difficult and expensive to operate and maintain as well as acting as a reminder to check on regular maintenance issues.
- Establish a plan for maintenance of the plant structures. Cleaning, painting and repair are important for long service-life. Usually water is treated in wet, corrosive conditions and protective coatings need to be periodically repaired. The failure to repair concrete surfaces can expose reinforcing steel, eventually weakening the structure.
- Use photographs where possible. Whenever it is important to record a specific condition, a photograph can be a useful, exact record of the condition at a given time.

Good plant records can be extremely valuable when making plans to improve plant performance, or when deciding on replacements for failed equipment. Example 3 below shows the sort of information that might be entered into a maintenance record.

**Example 3:** A pump maintenance and repair record, illustrating typical entries

<b>Maintenance record for</b>	High Lift Pump No. 1
<b>Equipment data</b>	Manufacturer, model, serial number, power rating, maximum flow rate, etc

<b>Date</b>	<b>Record</b>	<b>Operator initials</b>
25-01-07	Installed new packing rings.	AM
10-02-07	Checked and greased.	AM
20-02-07	Old impeller badly worn. Installed new impeller.	PE
28-02-07	Noticed unusual noise. Reported to water supply committee.	PE
10-03-07	Noise continues, so called in servicing contractor.	AM
11-03-07	Servicing contractor inspected pump and motor. Repair work scheduled.	PE

## 4 Improving the Source

### 4.1 Minimisation

In the *Treatment Options* booklet, the principles of minimisation, removal and inactivation are explained. **Minimisation**, the first principle of water management, involves managing the catchment to reduce the chances of potential hazards entering the water supply. Implementing this principle requires knowledge of what activities are happening in the catchment area, what risks may be there, and how those risks can be managed. In other words, it is important to understand the 'behaviour' of the source in terms of quality and the amount available, such as:

- river flows or well levels at different times of year
- impact of upstream abstraction
- changes in quality and quantity due to weather and how long these changes last
- the type of upstream activities and why they present risks
- the type of geology and flow patterns of the river.

### 4.2 River intakes

River intakes can take a number of forms but generally include a weir to control the water level and a screened intake to withdraw the water (see Figure 4). Behind the screen there is likely to be a stilling chamber to collect sediment so that it does not accumulate in downstream pipework.

**Figure 4:** Common features of a river intake

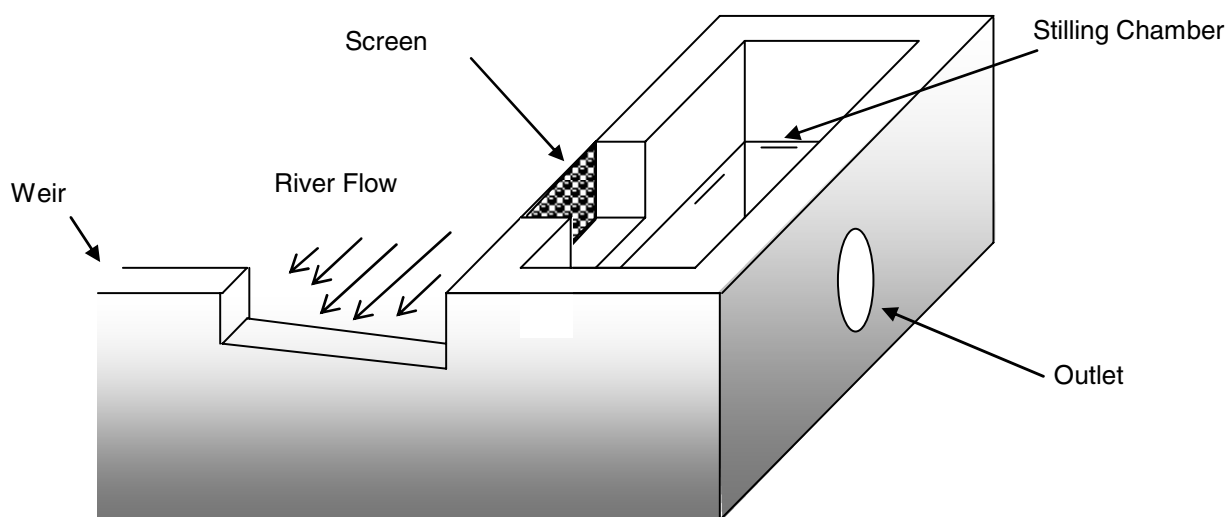

## **Operating targets**

The design of the structure and the screens needs to remove floating debris, fish and sediment such as sand and gravel. The location needs to be selected either to make use of natural scour holes and the way that watercourses transport sediment, or to minimise the effort needed to clear away deposited material.

## **Water quality records**

Records for the intake may be required as part of the resource consent conditions. Details may include, for example:

- abstraction flow rate
- residual flows
- impact on watercourse of cleaning screens and scouring away sediment
- effectiveness of fish passage
- river conditions, including:
  - river levels
  - turbidity
  - *Escherichia coli* (*E. coli*).

## **Inspection (and recording)**

The inlet should be checked at appropriate intervals for:

- accumulation of debris on the screen and in the sand trap and pipework
- seepage and bypassing of water
- valve and penstock condition
- corrosion of steelwork
- erosion undermining the structure (this must be repaired immediately)
- cracks in the concrete structure.

## **Maintenance (and recording)**

The screen and stilling chamber (sand trap) will normally need regular cleaning to remove debris. Any damage will also need to be repaired. The amount of work required will depend on the river conditions.

Valves and penstocks need to be operated through their range at regular intervals to prevent seizing. Instruments such as those recording water level and turbidity will need regular calibration.

If the system incorporates a mechanical system to clear debris such as air blowers, then these will need maintenance as well.

Table 1 describes some important indicators of maintenance problems that may arise, and identifies one or more solutions in each case.

**Table 1:** Problems and solutions related to maintaining river intakes

Indicator	Possible problem	Solution
Build-up of sediment over intake	Changing watercourse	Are river conditions affected by an unusual climatic event, such as an extended dry period or flooding? One-off removal of material may be sufficient. Can the watercourse be altered? Resource consent may be needed.
	Issue with intake design	Seek specific advice.
Excessive turbidity or colour after rain	Runoff	Consider storing water so that water does not need to be taken at these times.

### 4.3 Infiltration galleries

Typically, construction of an infiltration gallery involves placing perforated pipes in a stream bed and connecting them to a collection area, or **sump** (see Figure 5). Water seeps into the perforated pipes and flows to the sump, where it is pumped out (or flows by gravity) for immediate use or storage.

**Figure 5:** Infiltration gallery

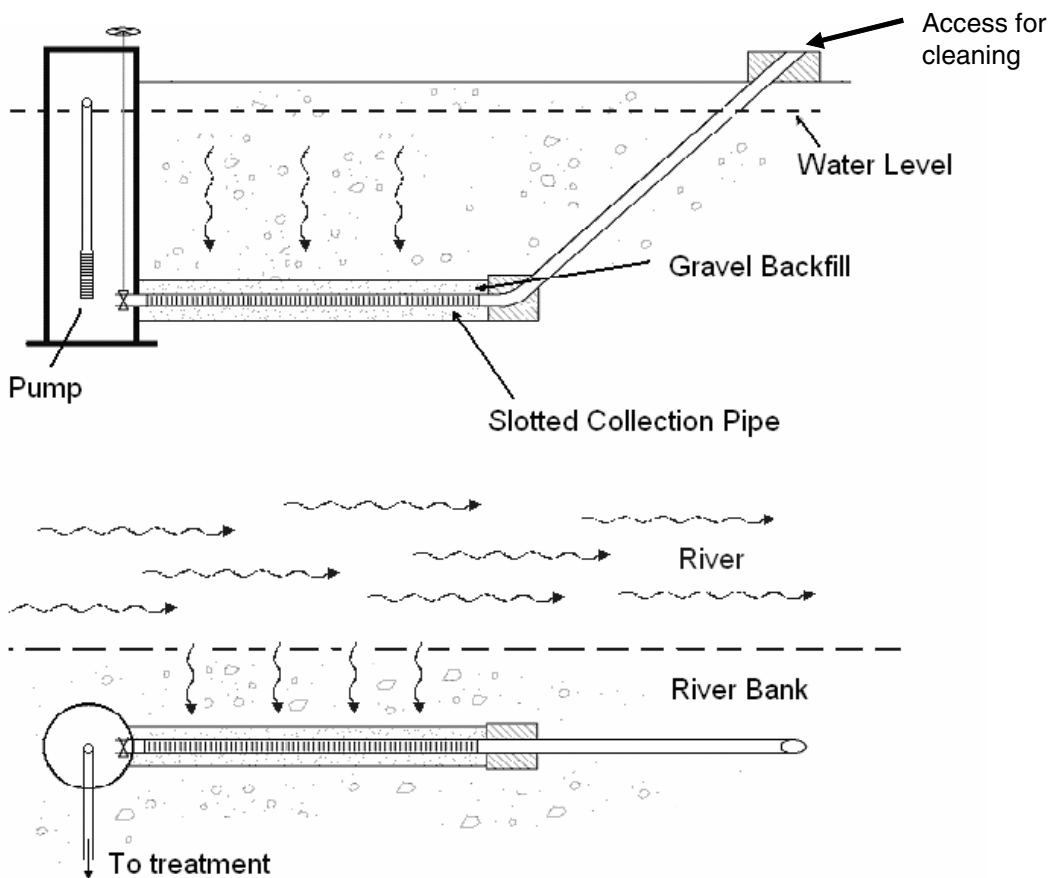

## **Operating targets**

The design of infiltration galleries should strike a balance between ensuring good flow into the gallery and achieving a degree of water treatment by filtration and adsorption on to the sediments. Some galleries will remove large material like leaves and silt but have no real effect on turbidity and other contamination. Others will considerably reduce the turbidity of the water and make a real difference to the water quality. The operating target for the gallery will depend on raw water quality, river bed conditions and groundwater levels.

## **Water quality and quantity records**

Records should cover intake performance against resource consent limits, for example:

- abstraction flow rate
- residual flows
- impacts on watercourse of scouring away sediment from the river bed.

Gallery outlet conditions to be recorded include:

- turbidity
- *E. coli*.

## **Inspection (and recording)**

Flow rates should be monitored for any unusual reduction or increase in flow that might relate to the condition of the gallery.

The condition of the structure and equipment should be checked regularly. The inspections should include:

- looking at the general condition of the base of the pump well, inlet pipes, mounting brackets, covers and hatches
- checking the amount of sediment on the pump well floor
- checking the general condition of the pumps, flow meters, level switches and valves.

It is difficult to estimate the amount of sediment in the pipes simply by looking, given that the pipes are below the water level. Instead it may be possible to detect the need for cleaning by a larger draw down than normal within the pump well (if there is one) for a given pumping rate.

## **Maintenance (and recording)**

A significant problem for infiltration galleries is blockage of the perforated pipes with fine sediment. Although many infiltration galleries are equipped with a reverse pumping feature, or air blowers, sediment can still cause problems.

Regardless of any previous sediment problems in gallery pipes, it is a good idea to clean out all these pipes every two years or so. If no sediment, or very little, is found, then the regular cleaning could be reduced accordingly. Clearly it is essential to have an easy means of access to galleries so that this periodic cleaning of sediment is possible.

Sometimes it is necessary to hire a digger to ‘scarify’ the bed of the river to free up the sediment so that water can flow more freely to the gallery. Obviously, care must be taken not to damage the gallery! The local regional council should also be consulted about its requirements.

Table 2 describes some important indicators of maintenance problems that may arise, and identifies one or more solutions in each case.

**Table 2:** Problems and solutions related to maintaining infiltration galleries

Indicator	Possible problem	Solution
Turbidity removal is poor.	Particles not removed by gallery	Consider treatment for turbidity removal.
Flow rates through gallery are declining or have ceased. The well draw down has increased for a given pumping rate.	Media becoming blocked	Check pump. Clean or clear screen.
	Pump failure	
	Screen or pipework becoming blocked	
River bed is migrating away from gallery.	Changing water course	Are river conditions affected by unusual climatic event, such as a dry period or flooding? Can the water course be altered or the gallery moved? Resource consent may be required.

#### 4.4 Bores

A bore is a well drilled into an aquifer (see Figure 6). There is often a screen at the bottom that supports the material around the bore. If the water flows to the surface without any need for pumping, the well is called **artesian**.

Normally a bore pump is needed to lift the water to the surface. These pumps are powered by an electric motor that is designed to be submerged. The pump unit is placed above the motor and under a check valve.

The top of the bore at ground level called the bore head or wellhead needs to be constructed in such a way that surface water is prevented from entering the bore and contaminating the bore water. This can be done by constructing a concrete apron around the bore which slopes away from the centre where the bore pipe comes up. It is important that the concrete apron does not have any cracks or holes which would allow surface water infiltration.

**Figure 6:** Typical bore

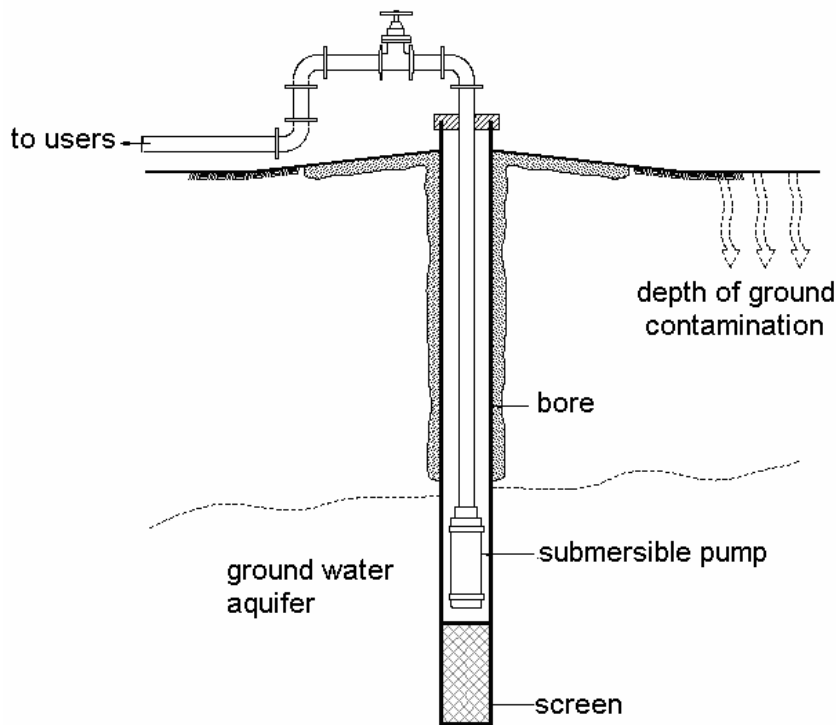

### **Operating targets**

Operating targets will depend on the bore design and the nature of the aquifer. If the bore has secure status under the Drinking Water Standards, then a target of zero contamination indicated by *E. coli* testing will be used to be sure that the water is safe. Secure bores are generally deep if the aquifer is ‘unconfined’ (no impervious layer above it). If the bore does not have secure status, then the water needs to be treated to remove or destroy microbial contaminants.

Treating bore water to achieve targets for chemical contamination is common. This treatment is most often for one or more of turbidity, iron, manganese, corrosivity eg carbon dioxide and sulphide.

The bore also needs to be operated to prevent excessive draw down of the water level (which could damage the bore and pump) and to comply with resource consent limits on abstraction rates. Care should be taken if the flow rate is to be increased significantly, such as by installing a larger pump.

### **Water quality and quantity records**

Records should be taken of intake performance against resource consent limits, for example:

- abstraction flow rate and volume
- well level.

Bore operating conditions and water quality details to be recorded include:

- turbidity
- *E. coli*
- chemical contaminants (eg, pH, carbon dioxide, manganese, iron).

### **Inspection (and recording)**

Changes to the following basic information can give an early warning of problems as they develop:

- general condition of equipment, such as leaks, corrosion and instrument failures
- general condition of surroundings, such as fencing and drainage
- pump running current (amps)
- pump operating hours.

If a monitoring well is installed, then the level in this well can also be monitored to see how the aquifer is affected by pumping.

### **Maintenance (and recording)**

Bore pumps usually operate out of sight, receiving little attention until something goes wrong. Because it is time consuming to retrieve a bore pump, the pump condition cannot be directly checked very frequently. This work is normally done by a contractor who specialises in looking after bores and bore pumps. It is good practice to follow the pump manufacturer's recommendations for how often to check the pump and what to check for. As an example, the manufacturer might recommend checking for unusual noise or vibration, signs of water in the lubricant, condition of glands and seals, and general signs of wear and tear after a particular number of running hours (say 10,000). Running current, earth loops and insulation can be tested by an electrician.

Running hours, problems, maintenance and repairs should be recorded in a logbook.

Sometimes the performance of the well can deteriorate, meaning it has to be **redeveloped**. A specialist company will be needed for this work. There are various rehabilitation techniques, such as forcing air or water into the well, brushing, over-pumping, and treating with chemicals.

If a well is abandoned, then it is important to protect the aquifer by removing equipment and permanently sealing the well. Otherwise the well could become a source of contamination to the aquifer. Again, a specialist contractor should do this work, and advice should be sought from the regional council.

Table 3 describes some important indicators of maintenance problems that may arise, and identifies one or more solutions in each case.

**Table 3:** Problems and solutions related to maintaining bores

Indicator	Possible problem	Solution
<i>E. coli</i> detected in groundwater that has been assessed to have 'secure' status	Water contaminated by sampling technique	Take more samples to see if further positives are detected. Any positive result has to be reported to the drinking water assessor (DWA).
	Contaminated water entering well from surface	Check well design to make sure water is not getting into the well from the surface.
	Contamination of aquifer	Seek advice from the regional council.
Change in turbidity or colour	Surface water intrusion into bore	Can the intrusion be prevented? Is it necessary to take water when the quality is poor?
	Damaged well screen or casing corroded	If the bore has a steel casing, a drilling contractor may be able to replace the screen.
	Drawing in water from a different part of the aquifer	Does it relate to the rate of water extraction from one or more bores in the aquifer?
Water turbid during the first stages of pumping	The rising main within the bore corroding	Can the first flush of water be diverted to waste? Inspect the rising main in the bore. Examine the inlet screen, valve and pipe connections. Replace badly corroded pipes.
Sand in well discharge and/or excessive pump impeller wear	Damaged well screen or casing corroded	If the bore has a steel casing, a drilling contractor may be able to replace the screen.
	Flow drawing sand into the well	Throttle back the flow rate to reduce the problem. A drilling contractor may also need to redevelop the bore to flush out the sand around the bore screen (or take other measures, as appropriate).
	Rapid stop / start pumping agitating the bore and not flushing out the sand	Look at pump controls. Install storage or variable speed drive (not always appropriate).
Pump vibration	Cavitation caused by inadequate pump submergence	The flow rate should be throttled back to reduce the draw down.
	Unbalanced pump or worn pump components	Have the pump serviced.
Pump cutting out on over-temperature or high amps	Pump needing repair	Have the pump serviced.
	Pump cycling too quickly between start and stop	Look at pump controls. Install storage or variable speed drive (not always appropriate).
Sudden change in flow rate	A flow restricting valve left open	Find the problem and fix as appropriate.
	A leaking pipe	
	Damaged pump	

Indicator	Possible problem	Solution
Gradual decline in pump flow rate	Pump wear or flow constriction in delivery pipework	Check pump 'shut off pressure' against previous values to see if the pressure is falling. Do not run a bore pump for any longer than necessary against a closed valve. Have the pump serviced.
The bore 'draw down' increasing	Water demand exceeding the capacity of the bore	Is another bore needed?
	Aquifer becoming depleted	Are other bore users in the area noticing increased draw down? Investigate water extraction in the local area and consider the effect of recent weather.
	Plugging of bore screen	Consider screen corrosion, chemical encrustation, biological fouling and build-up of fine material. A drilling contractor would normally undertake any remedial action.
	Gradual blockage of the area around the bore affecting water recharge	A drilling contractor may be able to redevelop the bore.

## 4.5 Springs

A spring is a place where water wells up out of the ground from an aquifer. Normally, if the water is being collected for drinking, a chamber is placed around the point where the water reaches the surface to protect it against surface contamination. Because the water is at the surface or drawn from near the surface it is easily contaminated, both by infiltration into the ground, and at the spring outlet (Figure 7).

**Figure 7:** Contamination of spring water

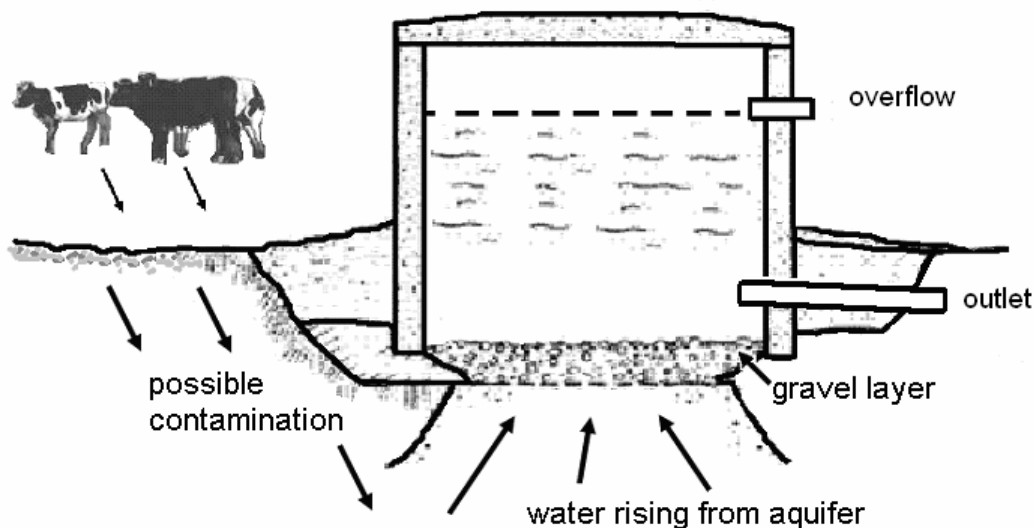

## **Operating targets**

The level of treatment required for spring water depends on the risks associated with the spring. Spring water is normally considered to be at risk from pathogens, and spring structures need to be operated and maintained to prevent contamination.

Chemicals found in spring water are generally similar to those found in groundwater but less likely to be present. Operating targets will depend on the spring design and the nature of the aquifer.

## **Water quality records**

Keep a record of:

- performance against resource consent limits – for example, abstraction flow rate and volume
- spring water quality including:
  - turbidity
  - *E. coli*
  - chemical contaminants.

## **Inspection (and recording)**

Check the structure at appropriate intervals for:

- water flow (water should flow freely to prevent it finding another way out of the aquifer)
- accumulation of debris
- seepage and bypassing of water
- valve or penstock operation (they can seize with disuse)
- corrosion of steelwork
- cracks in any concrete structures and erosion underneath them
- integrity of fencing (preventing animal access)
- effectiveness of land drainage (should be directing surface water away from the spring site to prevent contamination).

## **Maintenance (and recording)**

The following tasks are commonly needed.

- A washout valve should be opened regularly and the accumulated silt removed.
- Any leaks into the chamber from the ground outside it must be repaired urgently.
- Damage caused by erosion or by the soil settling could undermine the structure and should be repaired.
- When structural components (timber, steel and concrete) deteriorate, they should be repaired.
- Vegetation around the spring should be managed, as roots can find their way into the aquifer and collection box, causing damage.

Table 4 describes some important indicators of maintenance problems that may arise, and identifies one or more solutions in each case.

**Table 4:** Problems and solutions related to maintaining springs

<b>Indicator</b>	<b>Possible problem</b>	<b>Solution</b>
Flow rate declining	Increased water extraction from aquifer	Seek advice from the regional council.
	Less water entering aquifer	
	The spring has found another outlet.	
<i>E. coli</i> previously absent but now found	Change of land use or waste disposal	Seek advice from the regional council.
	Spring collection chamber no longer secure	Inspect and repair
Increase in turbidity or flow after rain	Contaminating surface runoff	Identify the source of the runoff and improve the protection of the spring.
	Water infiltrating into aquifer too close to the spring to be filtered	Consider storing water so that there is no need to take water from this source after rainfall.

## 5 Improving Pre-treatment

It is frequently necessary to pre-treat water, particularly surface waters, to reduce the load on the treatment plant. For small supplies, this process would usually be undertaken with an infiltration gallery (see Section 4), roughing filters or settling. Another option is **selective abstraction**, which means turning off the supply and using stored water when the source is dirty.

Pre-treatment can be used to improve the performance of downstream processes that are being overloaded.

### 5.1 Roughing filters

In New Zealand, the most common forms of roughing filters are steel screens, disc filters (see Figure 8a) and media filters (as described in Section 6.2).

In general, the size of the openings controls the size of the particles that will be removed and, as the openings get smaller, more pressure is lost. Either manual or automatic flushing may be used to clear debris.

Another type of roughing filter is a horizontal flow gravel media roughing filter, which operates primarily by settling out particles on to the media (see Figure 8b).

**Figure 8a:** Disc filter



**Figure 8b:** Horizontal flow gravel media roughing filter

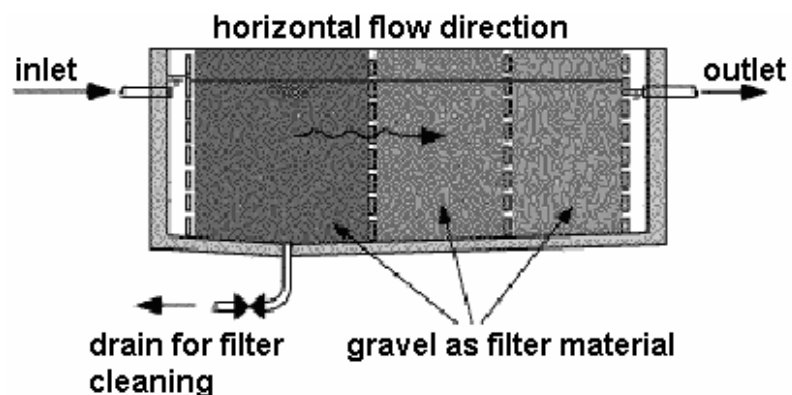

#### Operating targets

Roughing filters will not remove fine sediment. However, although they can only remove coarse material, they can still reduce the load on the treatment processes that come later. For example, pre-filtration upstream of cartridge filters can reduce how often the cartridge needs to be replaced.

#### Water quality and quantity records

Record operating conditions and water quality including:

- water level

- flow
- backwash intervals
- pressure loss
- inlet/outlet turbidity.

### Inspection (and recording)

The filter should be checked at appropriate intervals for:

- accumulation of debris
- seepage and bypassing of water
- physical condition, including of valves and other equipment.

### Maintenance (and recording)

Common maintenance tasks are:

- cleaning screens
- repairing structures for corrosion and coating damage
- maintaining sand filters, or media filters.

Table 5 describes some important indicators of maintenance problems that may arise, and identifies one or more solutions in each case.

**Table 5:** Problems and solutions related to maintaining roughing filters

Indicator	Possible problem	Solution
No difference in suspended solids between upstream and downstream samples	Suspended solids smaller than the cut-off size for the filter	Cut-off size could be reduced if practical. Consider operating problems that may arise if a smaller cut-off size is installed.
	Damaged filter	Check filter
Lack of flow	Blocked filter	Check filter backwash procedure. Inspect for biological growth

## 5.2 Raw water storage

Raw water storage can be used to improve water quality in a number of ways.

1. When untreated water is stored, the larger sediments will settle to the bottom rather than go on to treatment, improving the quality of the water that is treated.
2. Water storage can be used to allow the intake to be turned off when source quality is poor. This process is called **selective abstraction**.

Raw water storage is not the only option. Treated water storage can also be used to improve a drinking water supply. There are advantages and disadvantages of using treated and untreated water storage and the two types of storage are compared in Table 6 below. Treated water storage is covered in section 8.

**Table 6:** A comparison of untreated and treated water storage systems

Type of storage	Advantages	Disadvantages
Untreated water storage	A cheaply constructed pond or large storage tank, or a number of tanks in series can be used. Some improvement in quality through settling can occur, if the storage period is long enough.  Selective abstraction	An uncovered pond can lead to algal growth, which can cause problems for treatment and unpleasant tastes.
Treated water storage	The water storage also operates as a back-up for water supply if there are problems with the treatment process and to allow for fire fighting requirements.  Allows steadier treatment rates so smaller treatment units can be purchased	Treated water storage can cost more to install because covered tanks are needed. Very long periods of storage can reduce the chlorine residual.

### Operating targets

If turbidity is to be reduced to a significant degree, raw water needs to be stored for at least one week or a coagulant must be dosed to increase the rate of settling. Performance depends on many factors, including physical layout, turbulence and water quality.

If the storage is used to allow the plant to remain off line during periods of heavy contamination, then it must be a size that will allow time for the source water to improve. A target should be set for maximum water turbidity, above which water would not be taken for raw water storage and treatment.

Operating requirements for treated water storage are discussed in Section 8.

### Water quality and quantity records

Keep a record of operating conditions and water quality, including:

- water level
- flow
- inlet/outlet turbidity (and any other parameters being targeted)
- stored water quality
- overflow rate.

### Inspection (and recording)

The tank or pond should be checked at appropriate intervals for:

- accumulation of sediment, floating debris, vegetation, oil, scum, biological growths
- seepage and bypassing of water
- valve operation

- physical condition.

### Maintenance (and recording)

Common maintenance tasks are:

- cleaning debris and sediment
- repairing structures such as access ladders for corrosion and coating damage
- calibration of level monitoring equipment
- repair of leakage.

Table 7 describes some important indicators of maintenance problems that may arise, and identifies one or more solutions in each case.

**Table 7:** Problems and solutions related to maintaining raw water storage

Indicator	Possible problem	Solution
Algae growing in water storage	Stored water containing nutrients is exposed to light.	If the tank/pond is small, cover it to exclude light.
Stored raw water of poor quality seasonally (usually in autumn) – commonly high manganese, sulphide levels	In large, deep reservoirs, the upper layers can cool enough to cause a circulation current which brings settled material up from the bottom layer.	Generally treatment capacity is increased to cope.
Poor solids removal across tank	Sediment build-up in tank	Clean out sediment by draining or by vacuum hose (a permanent system could be installed)
	Poor flow path across tank	Look at location of inlet and outlet. Does the tank have a calmed inlet? If tank level varies, is there a floating draw off?
	Particles too fine to settle out before the water leaves the tank	A chemical coagulant could be added to the water.

## 6 Improving Filtration (Media and Cartridge Type)

Filters physically remove particles, including protozoa, from the water. In many plants, filtration is the only barrier to protozoa such as cryptosporidium. Therefore filters need to be operating well at all times and their optimisation is particularly important.

A very low turbidity target is set for filters acting as a barrier to protozoa because it has been found that this corresponds to good protozoa removal.

### 6.1 Cartridge filters

A cartridge filter consists of one or more filter elements which slot into a housing. The cartridge can be made of a rigid or a flexible material and has to be thrown away when it becomes blocked.

Cartridge filters are well suited to small water systems because they are simple and are inexpensive provided that the cartridges do not need to be replaced too often (see Figures 9a and 9b).

**Figure 9a:** Cartridge filter system



**Figure 9b:** Used cartridge filters



### Operating targets

The size of the particles that have to be removed is related to the size of the holes in the filter cartridge that allow the water to pass through. Filter cartridges are described as having a pore size that is absolute or nominal. If a pore size is 5 microns absolute, then it will remove all particles larger than 5 microns. If it is 5 microns nominal then it will remove most of the particles that are larger than 5 microns. Probably about 90%. A maximum pore size of 1 microns absolute is needed to remove protozoan cysts such as giardia and cryptosporidium. Filter cartridges need to meet NZS4348 (1995) to confirm that the cartridge removes protozoa effectively.

For the removal of inorganic material from the water, the following size ranges are relevant:

- clay, < 2 microns (ie, 0.002 mm)
- silt, 2–20 microns
- fine sand, 20–200 microns.

Clearly a 3 micron filter will not remove very fine material such as clay, so water dirty with clay will remain dirty. To reduce the turbidity due to clay, even 0.5 microns absolute is sometimes insufficient and such small pore sizes can quickly block. To reduce turbidity it will be necessary to try different pore sizes to find the size best suited to the source water.

### **Water quality and quantity records**

Keep a record of operating conditions and water quality, including:

- inlet/outlet pressure
- flow
- inlet/outlet turbidity (and other parameters being targeted).

### **Inspection (and recording)**

The filters should be checked at appropriate intervals for:

- initial head loss or pressure differential (measured at start-up) – compare with normal figure and manufacturer’s specification: if it is lower than normal, there may be a leak in one of the seals
- operating filtered water turbidity through the filter run
- cartridge condition
- rise in pressure differential (or fall in outlet pressure) as the water passes through the filter(s). The pressure differential will gradually increase as the filter blocks. If pressure differential drops suddenly, then the filter may have burst, or it may have ‘unloaded’ some of the particles that it has collected.

### **Maintenance (and recording)**

It is important to make sure that cartridges are installed correctly. Some types may not sit on their seal as well as others. Cartridge filters must be routinely checked and periodically replaced. The date that a new cartridge is installed should be recorded so that its length of service (and, if possible, volume treated) can be checked. To allow the filtration process to settle down when starting up or restarting, it is strongly recommended that water is filtered to waste for the first five minutes of the filter cycle.

It is important not to change cartridge specifications over time, without a proper review of the purposes for which they are designed.

Table 8 describes some important indicators of maintenance problems that may arise, and identifies one or more solutions in each case.

**Table 8:** Problems and solutions related to maintaining cartridge filters

Indicator	Possible problem	Solution
Rapid increase in head loss and short filter runs	Incoming water too dirty	Install or improve pre-treatment. Consider putting a coarse cartridge filter upstream.
One filter blocking much earlier than the others	Excessive flows to an individual filter	The flow split may need better control.
Spikes in filtered water turbidity during a filter run	Sudden changes in flow rate to a filter or filters is causing them to unload, particularly where high pressures are allowed to build up	Look for causes of sudden changes in flow to the filters. Use slow operating valves to control flow to the cartridges. Some valves are opened by the 90 degree turn of a handle. As a result, the flow can go from zero to full very quickly. Valves that require many turns to open them are preferable.
Flow declining and possible increase in treated water turbidity	Changing cartridges too late	Is the pressure differential being checked regularly enough?
High filtered water turbidity	Cartridge pores too large	Investigate reducing the cartridge pore size or changing from a nominal size to an absolute size. Of course, if more material is removed, then the cartridge will have to be replaced more often. It may not be practical to remove very fine sediment with cartridges.
	Cartridge starting to unload	Replace cartridge. Take a note of pressure differential. Has it been allowed to get too high?
	Ruptured cartridge	Replace cartridge. Is the upstream pressure too high? Was the cartridge damaged before installation?
Heterotrophic plate count increases across filter	By concentrating particles in one area, cartridge filters can contribute to growth of non-coliform bacteria	The problem is difficult to prevent but its effects can be minimised with frequent cleaning and cartridge replacement.
Initial pressure differential is low.	Cartridge is not sitting on the seal properly	Refit cartridge

## 6.2 Media filters

In a media filter, particles in the water are removed by being trapped between grains of sand or other material. Some are removed by simple straining but very small particles can also be removed by attachment to the filter grains (see Figures 10a and 10b). Because these particles are only loosely attached to the grains, the filter must be operated very carefully to avoid disturbing the particles allowing them to pass further through the filter. Regular and effective backwashing is also important to prevent particles escaping from the filter material. Normally a chemical coagulant is dosed

upstream of media filters. If coagulation is not in place, it may be wise to investigate whether other treatment processes are also needed. Assessing and adjusting the coagulation dose is very important to ensure coagulation is optimised. The *Guidelines for Drinking-water Quality Management for New Zealand* outline in considerable detail how to do this. The chapter on coagulation can be found at [http://www.moh.govt.nz/moh.nsf/0/5A25BF765B400911CC25708F0002B5A8/\\$File/13-coagulationprocesses.pdf](http://www.moh.govt.nz/moh.nsf/0/5A25BF765B400911CC25708F0002B5A8/$File/13-coagulationprocesses.pdf)

Two common types of media filters are the rapid gravity filter (Figure 11) and the pressure filter (Figure 12).

**Figure 10a:** Straining of particles

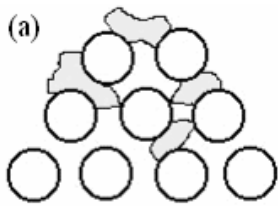

**Figure 10b:** Attachment of small particles

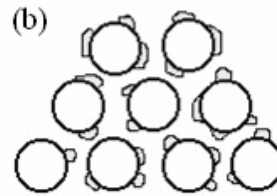

**Figure 11:** Rapid gravity filter

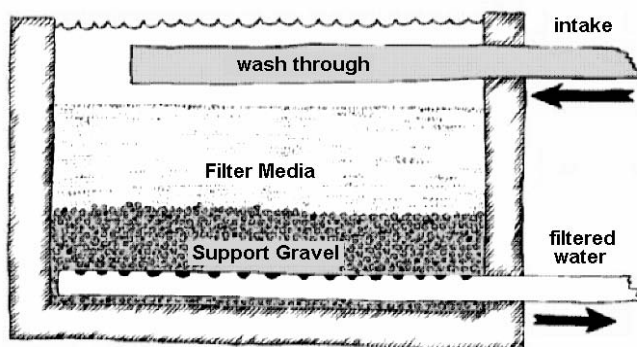

**Figure 12:** Pressure filter

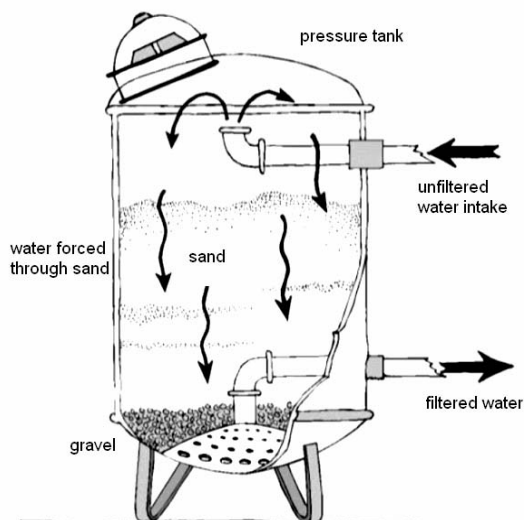

## **Operating targets**

Well-run, well-designed filters with pre-treatment can achieve very good quality water with turbidity of less than 0.1 nephelometric turbidity units (NTU). Good performance for a small-scale plant with fewer resources for operation and monitoring would be having a filtered water turbidity of less than 0.3 NTU. With good pre-treatment, the operator can achieve long and predictable filter runs, generally lasting more than 24 hours, before a backwash is required.

The ideal backwash rate is specific to the size and density of the filter media. The backwash process does not wash the filter media absolutely clean so there is an initial turbidity spike when the filter is restarted. A useful procedure is to run the filtered flow to waste for a period when the filter returns to service.

To optimise performance, it is necessary to:

- remove as much of the particulate matter as possible by correct pre-treatment of the water
- avoid disturbing the particulate matter that has been collected in the filter
- operate the filter with as little change to the flow rate as possible
- backwash the filter effectively, and at the right time.

## **Water quality and quantity records**

Keep a record of operating conditions and water quality (for each filter), including:

- coagulant dose
- pH
- alkalinity
- outlet turbidity
- filter flow
- head loss across media
- water level in filter (gravity type only).

## **Inspection (and recording)**

Some evaluation techniques that can be used to optimise the running of a filter are:

- visual inspection during operation and particularly during backwash
- comparing the length of filter runs.

Many elements of visual inspection are only possible for gravity filters as it is not practical to view a pressure filter while it is running.

## **Maintenance (and recording)**

Common maintenance tasks are:

- filter bed cleaning

- calibration of turbidimeter, level transmitters, and differential pressure meters
- wall and launder cleaning
- inspection of pressure vessel for leaks or rust.

Table 9 describes some important indicators of maintenance problems that may arise, and identifies one or more solutions in each case. The shaded parts of the table are more appropriate to larger systems, particularly rapid gravity filters and systems where a coagulant is dosed. For small supplies, usually only the unshaded areas would need to be considered.

**Table 9:** Problems and solutions related to maintaining media filters

Indicator	Possible problem	Solution
Rapid increase in head loss and short filter runs	Incoming water too dirty	Improve pre-treatment performance. Consider changing a single media filter to a dual or multiple size media to increase the amount of dirt that can be stored.
	Excessive use of coagulant	Cut down use of coagulant if possible and clean the filter media. Chemicals may be needed.
	Inadequate backwashing	Look at backwash rates and other features.
	Air blinding in filter	Consider revising filter control or design. Water depth above filter may need to be increased, for example.
Uneven length of filter runs between filters	Excessive flows to an individual filter	The flow split may need better control.
	Backwashing problems on an individual filter	Look at backwash rates and other features.
Visible mudballs or cracking	Backwash unable to remove mud and silt	Investigate increasing backwash and air scour rates. The mudballs may have to be physically removed or broken up. Chemical cleaning and lancing may help.
Media 'boils' in localised areas; possible non-uniform media depth	Possible problem with the under-drains	It may be necessary to inspect the nozzles, which will require digging out the sand.
Uneven flow into troughs	Troughs not level Troughs in the wrong places	Check and resolve as appropriate.
Encrustation of media (which changes media size and shape)	Build-up of scale or other fouling on media	Fouling can usually be cleaned off using chemicals or, where it is surface build-up, scraped off the top.
Filter media in troughs	Loss of media with the backwash water	This problem has a range of possible causes. Resolve as appropriate if losses are significant.

<b>Indicator</b>	<b>Possible problem</b>	<b>Solution</b>
Spikes in filtered water turbidity during a filter run	Sudden changes in flow rate to a filter or filters	Look for and control situations where flow rate changes suddenly. For example, when one filter is taken off-line for backwash, the other may step up in flow and generate a spike.
	Poor coagulant dosing	Investigate optimising the coagulant dose or type.
	Growths in the under-drains	Investigate chlorinating backwash water or unfiltered water (only if unfiltered water is very clean and if the disinfection by products will not cause problems).
High turbidity at the end of a filter run	Initiating backwashes too late	Are methods available to identify when to start a backwash, other than waiting for turbidity to increase?  Methods could refer to the time or volume filtered since the last wash, the water level increase above the filter, or the pressure drop across the filter.
High turbidity at the start of a filter run	Residual turbidity being washed out of media	Only restart a dirty filter after backwashing it first.  Bring filters into service by ramping up flow very slowly.  Add a 'filter to waste' facility – where water is diverted away to waste while the water is turbid after a backwash.  Dose polyelectrolyte as a filter aid to mature the filter media.

## 7 Improving Disinfection

Disinfection is intended to inactivate many remaining micro-organisms in the water after the previous treatment steps. Some disinfection methods also provide a residual disinfectant to inactivate bacteria which could be introduced ingress of contaminated water during storage or distribution.

### 7.1 Chlorination

Dosing chlorine is an excellent method for killing bacteria and viruses in water. In water supplies it is normally dosed as chlorine gas or as sodium hypochlorite. It can be purchased as a liquefied gas in steel cylinders with a 68 kg capacity. Chlorine gas is corrosive when in contact with moisture and is especially destructive to electrical equipment. Thus sodium hypochlorite is often favoured over chlorine gas for small systems. Sodium hypochlorite is much easier and safer to handle for a less experienced operator. Calcium hypochlorite is also used in some small supplies.

For disinfecting water efficiently, high disinfectant concentrations work best because they will kill microbes quickly. Unfortunately a very high concentration of chlorine can make the water unpleasant to drink, as well as producing chemical reactions with organic material in the water that lead to by products which over long periods of time can be of significance to human health. For this reason, we tend to dose lower concentrations and store the water for long enough for the chlorine to act. The lower the chlorine concentration is, the longer the chlorine takes to disinfect the water. As a rule of thumb, at typical chlorine concentrations, there should be at least half an hour's storage with no short circuiting before the first outlet to a water consumer.

#### Operating targets

The chlorine dose must be large enough so that, after the reaction with the water, there is enough left over for a free chlorine residual in the water distribution system.

The pH has an impact on the effectiveness of the chlorine. When chlorine is dissolved into water, it splits into two forms. The most useful disinfecting form is hypochlorous acid (HOCl). Although varying slightly with temperature, about 78 percent of the chlorine is in this 'active' form at pH 7.0, but the proportion drops to only 28 percent at pH 8.0 (see Figure 13). It is important that chlorine is dosed when the pH of the water is at 7.0 and before anything causes the pH to increase. The pH should be kept below 8 through out the whole distribution system.

**Figure 13:** Relationship between pH and the form that chlorine takes in water

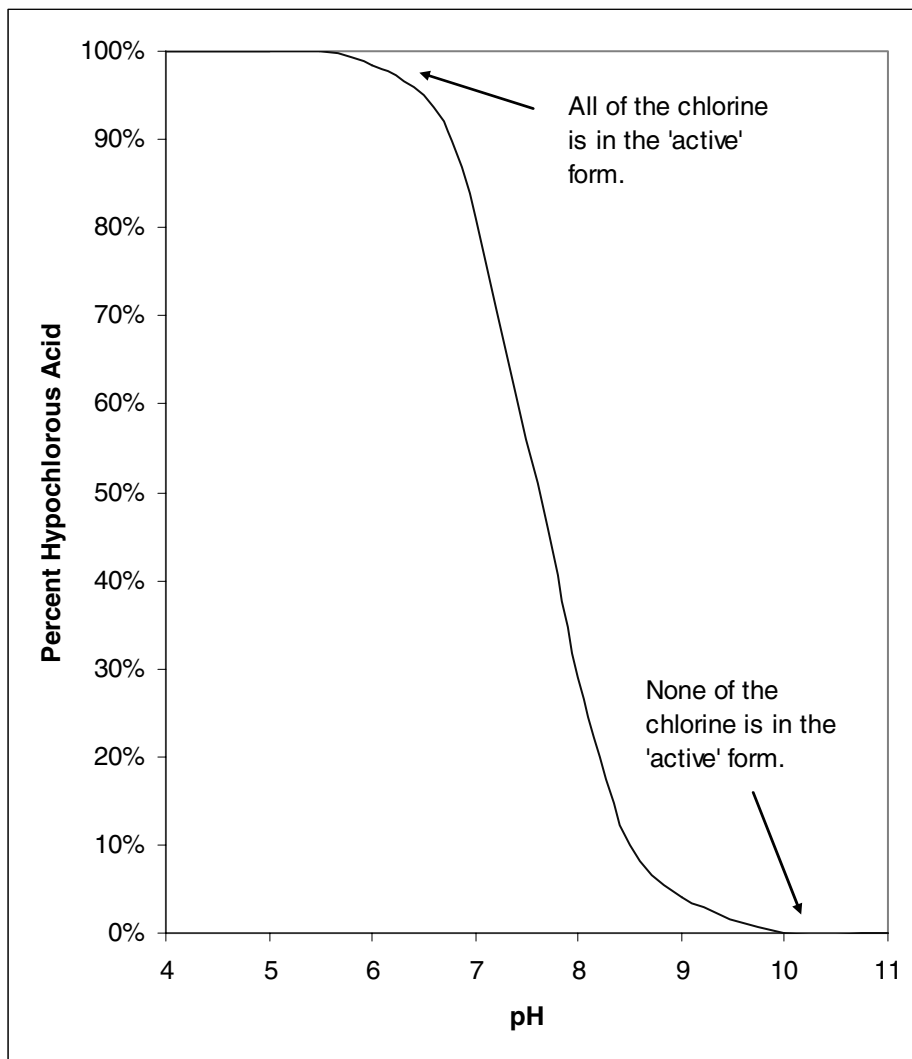

Note: These percentages vary slightly with temperature.

Particles in the water can shelter microbes from the effect of the chlorine. For this reason the water needs to be clean prior to disinfection. Ideally the turbidity should be less than 1 NTU.

### Water quality records

Traditionally, faecal contamination is detected by *E. coli* testing, however we have to wait for up to 24 hours for the results of *E. coli* testing. We can test the chlorine concentration to find out if we have a sufficient amount of chlorine to kill pathogens, and get a result immediately. So when chlorine is used, testing it gives an immediate indication of the level of disinfection being provided.

Keep records of operating conditions and water quality in the treated water and at strategic points in the network, including:

- free available chlorine concentration
- pH
- turbidity
- *E. coli*.

### **Inspection (and recording)**

The system needs to be inspected regularly to establish that it continues to be reliable. There are two main issues that need to be covered.

1. The accuracy of the dose rate needs to be confirmed to make sure that the correct dose and residual are being achieved. The easiest way to confirm this is with an on-line instrument but this may not be affordable in a small supply. Test kits are also available to test the residual chlorine manually.
2. Routine checks need to be made on the quantity of chemicals in storage so that it does not run out. If it does, it is preferable that the plant shuts down automatically until the operator gets to the site to initiate temporary measures. For example, there may be a spare supply of calcium hypochlorite (HTH) that could be dosed manually or using dosing pumps.

It is good to calculate the usage of chlorine and compare it with the volume of water treated. Then calculate the amount of chlorine used per cubic meter of water produced. This is called a mass balance calculation.

### **Maintenance (and recording)**

Common maintenance tasks are:

- testing the strength of sodium hypochlorite or calcium hypochlorite solutions (the solution strength reduces as it breaks down and needs to be kept out of direct sunlight)
- calibrating dose pumps
- calibrating instruments
- safety inspections, including testing for chlorine gas leaks in the case of a chlorine gas system
- changing chlorine cylinders (but never unaccompanied and always with personal protective equipment).

Maintaining gas chlorine systems is usually the responsibility of a contractor through a permanent service contract.

Table 10 describes some important indicators of maintenance problems that may arise, and identifies one or more solutions in each case.

**Table 10:** Problems and solutions related to maintaining chlorination systems

Indicator	Possible problem	Solution
Very low chlorine residual after contact tank	High chlorine demand from the water	Increase chlorine dose. Consider improving treatment to remove the contaminants that react with chlorine. Ensure slimes and sediments are not absorbing chlorine.
	Poorly operating or inoperative chlorination equipment	Check for blockages, air locks (hypochlorite), closed valves, operation of proportional dosing equipment.
	Chlorine has run out	Can the operator check the quantity more often? Has the dose rate increased suddenly? Can an alarm be fitted to alert the operator to this problem? Can a standby tank be fitted?
<i>E. coli</i> detected after contact tank, even though dose and contact time seem okay	Short circuiting means retention time insufficient for disinfection	Ensure that the contact tank remains full. Maximise the flow path between inlet and outlet. Try installing baffles in the contact tank to direct the flow. Install a calmed inlet to prevent jetting. If necessary, increase the chlorine dose concentration or install more storage.
	Tank has been contaminated	Look for sources of contamination, such as access by animals or infiltration.
	pH is too high	There are a number of solutions to this problem. For example, disinfection is improved if chlorine is dosed before alkali is added because disinfection works best at lower pH.
	Particles are masking the effect of the chlorine	Improve the upstream treatment processes to reduce turbidity so that microbes are not sheltered inside particles. Turbidity should be less than 1 NTU.
Free available chlorine declines over time even though the dose rate is the same	Sodium and calcium hypochlorite solution breaks down over time The deterioration speeds up as the temperature goes up The deterioration slows down as the concentration falls	Try not to store hypochlorite for too long. The dosing rate may need to be adjusted as the solution strength falls.

Indicator	Possible problem	Solution
The sodium hypochlorite pump runs but no liquid is pumped	An airlock may have formed in the dosing pump suction line (from the storage tank to the dosing pump)	Gas bubbles can evaporate off from the solution in the dosing lines. If this is a recurrent problem, then try arranging the tubes to allow bubbles to find their way out rather than becoming trapped. You can also try reducing the size of the dosing tubes to help sweep out the gas bubbles. Pump suppliers sell products that trap the gas at a high point in the line.

## 7.2 Ultra Violet light

Intense UV light can be used to inactivate micro-organisms, including protozoa (see Figure 14). However, although it is an effective disinfectant, it does not leave residual in the water to protect against any subsequent contamination.

**Figure 14:** UV disinfection system

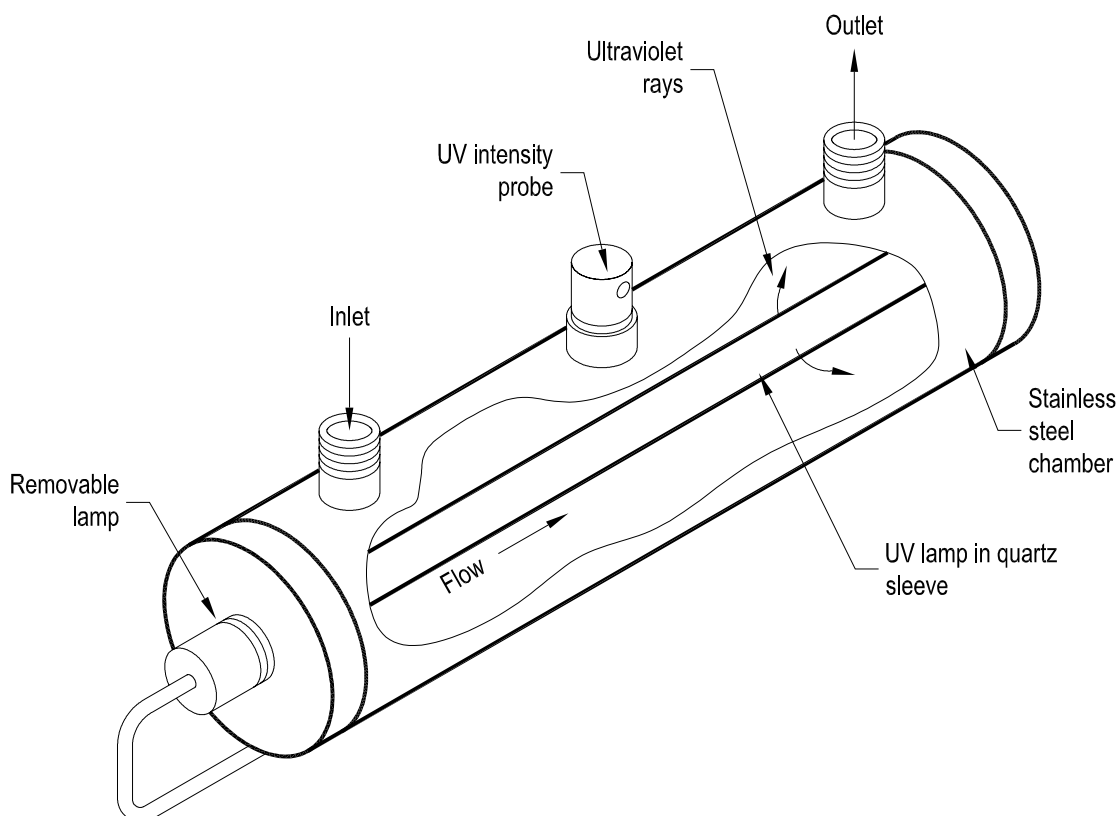

### Operating targets

As with chlorination, UV disinfection needs clean water to work well; particulate matter in the water can shield the pathogens from the UV light. The turbidity of the water to be disinfected should be less than 1 NTU.

The efficiency with which UV light passes through water can be tested by measuring UV transmittance at 254 nm (the wavelength that is used to inactivate pathogens). This

transmittance should be more than 80 percent. It may be reduced by, for example, organic material in the water. The concentration of such absorbing substances would have to be reduced by treatment before UV could be used.

UV systems should be equipped with a UV intensity sensor which checks the UV level in the unit to ensure a high enough dose is being provided to inactivate pathogens. These systems need to be fitted with a shutdown switch to stop plant flow if the UV intensity level drops too low.

### **Water quality records**

Although requirements vary with the size of the supply, monitoring of operating conditions and water quality may include:

- UV intensity
- UV transmittance
- flow rate (total)
- flow rate (each reactor) – can be a flow restrictor for supplies
- turbidity
- lamp replacement hour meter
- lamp outage
- ballast temperature.

### **Inspection (and recording)**

The unit should be checked at appropriate intervals for:

- lamp operation and intensity
- cleanliness of the quartz sleeve
- lamp hours completed
- any unusual noises from ballast cooling fans
- valve operation.

### **Maintenance (and recording)**

Common maintenance tasks are:

- cleaning the lamps so that sufficient light passes into the water
- replacing a lamp when UV intensity falls below the minimum needed for disinfection, or when the lamp has operated for the rated number of hours, or when it fails
- calibrating UV intensity meter / UV transmittance meter
- replacing the ballast unit.

Table 11 describes some important indicators of maintenance problems that may arise, and identifies one or more solutions in each case.

**Table 11:** Problems and solutions related to maintaining a UV disinfection system

<b>Indicator</b>	<b>Possible problem</b>	<b>Solution</b>
UV intensity low	Fouling of lamp sleeves	Lamp sleeves need to be cleaned.
	Lamps at end of service life	Replace lamps.
	Decrease in UV transmittance of the water – the minimum acceptable value is usually 80%	Look for reasons why the water quality has changed. Can water treatment improve the problem? Is there a problem with an upstream process?
Lamp not working	Lamp or ballast failure	Replace faulty component. Check ballast overheating. Keep spare lamps and ballasts.

## 8 Improving Treated Water Storage

Storage facilities are needed to provide enough water for a given period so that the plant can run at a more constant rate rather than have to match the water demand at all times over a 24-hour period. They are also needed in case a failure interrupts the supply from the treatment plant.

### Operating targets

The size of the storage tank needed depends on the particular needs of the community but the capacity for at least two days of water at the average flow rate is a good target. Enough water must also be stored to provide:

- minimum chlorine contact time if there isn't a dedicated contact tank
- time for the operator to arrive and fix problems at the plant when there is a breakdown – factor in more time if there is no automatic alarm to alert the operator to problems
- a buffer against times when a lot more water is used, such as during holiday periods in a tourist destination or for fire fighting.

### Water quality and quantity records

The water level of a storage tank must be monitored. A very simple system is a floating pole to indicate the level to passers-by. More sophisticated electronic systems automatically page the operator if levels become low.

Water quality should not be allowed to deteriorate while it is in storage. A storage tank needs to have a roof and be secure to prevent access by birds or rodents. If chlorine is used, particular attention needs to be given to chlorine levels, which can decline over long periods of storage.

### Inspection (and recording)

The tank should be checked at appropriate intervals for:

- the condition of tank interior, hatches, vents and overflows
- leaks from walls and under the floor
- entry points for contamination, such as broken screens on the vents or roof, water infiltration
- security of access hatches and ladders.

### Maintenance (and recording)

Regular maintenance includes:

- cleaning out accumulated sludge on the bottom of the tank
- removing biofilms on tank walls by water blasting
- periodic microbiological testing to confirm no contamination has occurred.

One good way to remove sludge from the bottom of a tank, if it cannot be emptied easily, is to use a swimming pool vacuum cleaner or a simple siphon.

Rough surfaces or crevices in the walls need to be prevented, or eliminated as soon as possible, as these are a haven for slimes and biofilms, which can shield some pathogens from chlorine. The risks are particularly high at the air-to-water interface and on scum lines or rings.

Any work that involves entering the tanks must be treated as a confined space entry and requires special standards for worker safety. The Department of Labour should be consulted about this procedure.

Table 12 describes some important indicators of maintenance problems that may arise, and identifies one or more solutions in each case.

**Table 12:** Problems and solutions related to maintaining water storage systems

Indicator	Possible problem	Solution
Wide fluctuations in the residual chlorine concentrations leaving reservoir	Poor mixing	Look for ways to ensure the water circulates effectively. Try to prevent dead areas. Consider the location and orientation of the inlet and outlet. Two tanks in series is better than one tank
	Wide variation in water use, including extremely long periods in the 'off season'	Consider operating the reservoir with a lower top water level when storage periods are extremely long.
Deterioration in water quality when water levels low; possible taste and odour issues	Sludge and scum accumulating in reservoir	Drain reservoir and clean it. It may be possible to use a siphon system to vacuum out sludge.

## 9 Places to Get Information

Table 13 below lists some people and places that can provide more information.

**Table 13:** Sources of further information

Source	Expertise	Listing in phone book
TAP facilitators	All aspects	District Health Board – Public Health Unit
Water testing laboratories	Water analysis and interpretation of results	Analytical laboratories. See the MoH webpage for recognised laboratories
Local water treatment plant operators	Operational advice	District councils and other water treatment plant owners
Regional council	Local water sources and likely contaminants, restrictions on use	Regional council
Specialist water treatment equipment suppliers	Capabilities of a particular supplier's equipment	Water treatment
Treatment plant designers	All aspects, especially system design	Environmental consultants
Master plumbers	System installation cost	Plumbers

For more detail, see also the *Guidelines for Drinking-water Quality Management for New Zealand* (Ministry of Health 2005) available online at <http://www.moh.govt.nz/moh.nsf/indexmh/drinkingwaterinnz-assistanceprogramme>

Chapter 1: Introduction  
 Chapter 2: Management of Community Supplies  
 Chapter 3: Water Sources  
 Chapter 4: Selection of Water Source and Treatment

Chapter 5: General Microbiological Quality  
 Chapter 6: Bacteriological Compliance (*E. coli*)  
 Chapter 7: Virological Compliance  
 Chapter 8: Protozoal Compliance  
 Chapter 9: Cyanobacterial Compliance  
 Chapter 10: Chemical Compliance  
 Chapter 11: Radiological Compliance

Chapter 12: Treatment Processes, Pretreatment  
 Chapter 13: Treatment Processes, Coagulation  
 Chapter 14: Treatment Processes, Filtration and Adsorption  
 Chapter 15: Treatment Processes, Disinfection

Chapter 16: The Distribution System  
 Chapter 17: Monitoring, Water Treatment and Drinking-water  
 Chapter 18: Aesthetic Considerations  
 Chapter 19: Small, Individual and Roof Water Supplies

## 10 Worked Examples

The following worked examples illustrate the techniques used for optimising water treatment processes. Each is a 'real life' scenario that draws on one of the preceding 'problems and solutions' tables.

### Scenario 1: *E. coli* detected in groundwater that has been assessed to have 'secure' status

A simple bore takes water from an aquifer 40 m below ground level (see Figure 15). The bore feeds water to a reservoir and is then pumped directly into supply. The bore has been assessed previously to be 'secure' but a routine water quality test produces a positive result for *E. coli*.

**Figure 15:** Groundwater from a simple bore water system (Scenario 1)

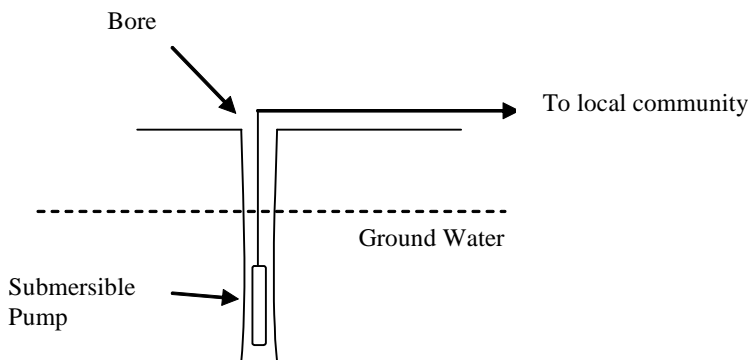

A 'secure' bore should be free of pathogenic organisms due to its design and the nature of the aquifer that supplies the water. When bacteria are detected in water from a secure bore, it is a matter for serious concern and needs to be reported to a drinking water assessor (DWA).

Table 3 (in Section 4.4) has addressed this indicator and the problems that may be underlying it.

#### a. Water contaminated by sampling technique

The bacteriological sampling technique requires skill and care to avoid contaminating the sample with organisms in the environment and on the hands of the sampler. Making a mistake with sampling technique can lead to doubts as to the secure status of the bore and concern in the community if a 'boil water' notice is issued.

Because of the risks involved, if a positive result for *E. coli* is obtained from a 'secure' bore, the DWA must be informed.

#### b. Contaminated water entering well from surface

Because bores penetrate directly into an aquifer, water can track down the inside or the outside of the bore casing to reach the clean groundwater below.

Therefore, to protect the groundwater against contamination and to achieve secure status, bores must meet particular design requirements. Measures that help to provide such protection include sealing the bore head and installing a concrete apron around it to prevent infiltration of water, excluding animals from within 5 m of the bore, providing an appropriate backflow prevention mechanism and constructing the bore itself according to the environmental standard for drilling soil and rock (NZS4411).

### c. Contamination of the aquifer

There is a slight possibility that bacteria could be found in an aquifer that was previously uncontaminated. For example, contaminated water could leak back into the bore and pollute the aquifer at disused bores and monitoring bores where there is not continuous water flow out of bore (which would purge it).

### Scenario 2: High filtered water turbidity from a cartridge filter system

Cartridge filter systems rely on the simple entrapment of particles in, or on, the porous structure of the cartridge (see Figure 16). In this scenario the operator has noticed that the filtered water turbidity has become consistently high.

**Figure 16:** Cartridge filter system (Scenario 2)

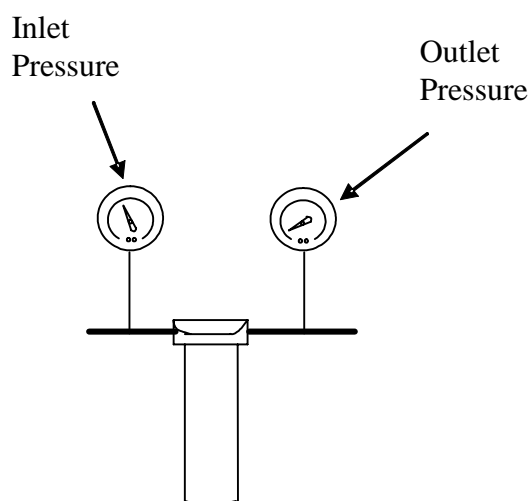

Table 8 (Section 6.1) has addressed this indicator and the problems that may be underlying it. Below is a more detailed explanation of the possible problems and their solutions.

#### a. Cartridge pores too large

The filter pore size would normally be selected when the filters are installed and would not be changed afterwards. However, the situation may have changed in the catchment such that there is now a need to remove smaller particles than previously (a landslide in the catchment may have led to a high silt/clay load, for example). In this case a cartridge with smaller pores may help to improve performance.

### b. Cartridge is starting to unload

As cartridge filters collect particles and become more clogged, the difference in pressure between upstream and downstream can increase. This pressure difference increases the force on the particles on the filter, with the result that some of them are forced through. In this case, the cartridge should be replaced straight away.

### c. Cartridge has ruptured

A ruptured cartridge obviously means that the water is getting little or no treatment. There will be little or no difference in pressure between the upstream and downstream sides of the filter. In this case, too, the cartridge should be replaced straight away.

## Scenario 3: UV intensity decreasing

A small water supply uses a UV unit for disinfection (see Figure 17).

**Figure 17:** UV disinfection unit (Scenario 3)

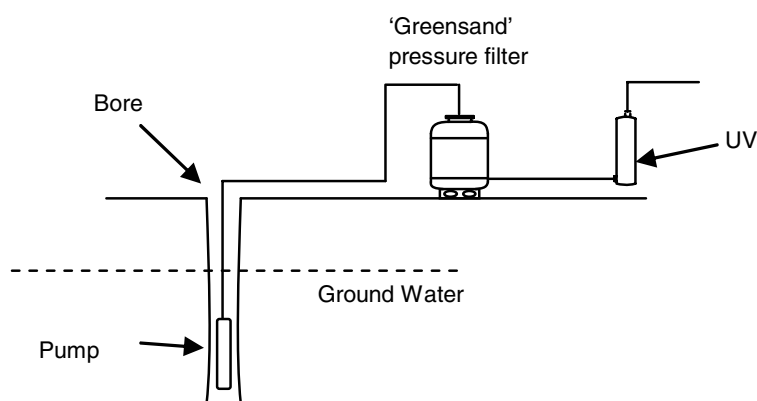

Water is pumped from a bore and is high in manganese. A greensand filter reduces manganese levels to improve the taste of the water.

The UV intensity sensor has activated a low-level alarm but the reason for the alarm has not been identified yet. The community has been told to boil water before drinking it, while the reason for the problem is located. The regular bacteriological testing is now giving positive results for *E. coli*.

Table 11 (Section 7.2) has addressed this indicator and the problems that may be underlying it. Below is a more detailed explanation of the possible problems and their solutions.

### a. Fouling of lamp sleeves

Iron and manganese will cause staining on the quartz sleeve at levels as low as 0.3 mg/L and 0.05 mg/L respectively. Pre-treatment is required to eliminate this problem.

Therefore, if the greensand filter is not removing sufficient manganese, black deposits will build up on the sleeves. These deposits can be wiped off, sometimes with the aid of a chemical. The equipment supplier will provide instructions on this procedure.

Reasons for the poor manganese removal should be investigated. For example, the greensand media may need to be regenerated with potassium permanganate.

The sleeve should be checked at regular intervals to ensure that it remains clean.

As an aside, hard waters can also lead to scaling, similar to the scaling inside kettles.

**b. Lamps are at end of service life**

The intensity of the light that a UV disinfection lamp gives off declines with age. The lamp supplier will rate the lamp for a certain number of hours (for example, 10,000 hours). If the lamp has been running for more than the rated number of hours, it may be time to replace the lamp.

**c. UV transmittance of the water has decreased**

UV transmittance represents the ability of UV energy to penetrate through the water. With UV disinfection, the normal usual acceptable value for UV transmittance is 80 percent.

Turbidity and dissolved organic material can affect this UV transmittance.

Turbidity is caused by the presence of suspended solids or particulate matter. It has a shielding effect in which a microbe may pass through the unit without being sufficiently exposed to the UV light.

Dissolved organic material such as humic acids, fomic acids and tannins will reduce the UV transmittance by absorbing the rays.

The operator should look for anything that has changed with the raw water quality or processes upstream of the UV disinfection unit that might have affected the levels of turbidity or dissolved organic material.