

# **Sampling and Monitoring for Small Drinking-water Supplies**

Resources for the Drinking-water  
Assistance Programme

Ministry of Health. 2007. *Monitoring and Sampling for Small Supplies: Resources for the Drinking-water Assistance Programme*. Wellington: Ministry of Health.

Published in September 2007 by the  
Ministry of Health  
PO Box 5013, Wellington, New Zealand

ISBN 978-0-478-19132-5 (print)  
ISBN 978-0-478-19135-6 (online)  
HP 4405

This document is available on the Ministry of Health's website:  
<http://www.moh.govt.nz>



MANATŪ HAUORA

# Contents

1	Introduction	1
2	Why Should We Monitor?	2
3	What Should We Be Testing For?	3
3.1	Sampling for micro-organisms	3
4	How to Collect Samples Correctly	5
4.1	Sampling containers	5
4.2	Sample identification and records	5
4.3	Sampling location	6
4.4	Samples from the environment – streams, springs, ponds	7
4.5	Tap sampling procedure	9
5	Testing Samples	11
5.1	Who should do the testing?	11
5.2	Description of tests	11
6	Remote Monitoring and Alarms	16
7	Recording and Storing Results	17
8	Worked Examples	18
8.1	Example A: Secure groundwater	18
8.2	Example B: Roof supply + chlorine addition	18
8.3	Example C: Roof supply + UV light	19
8.4	Example D: Groundwater + chlorine	20
8.5	Example E: Surface water + chlorine	21

## List of Tables

Table 1:	Recommended tests in response to key water quality issues	3
----------	---	---

## List of Figures

Figure 1:	Monitoring and sampling a secure groundwater source	18
Figure 2:	Monitoring and sampling roof water treated with chlorine	18
Figure 3:	Monitoring and sampling roof water treated with a UV system	19
Figure 4:	Monitoring and sampling a secure groundwater source treated with chlorine	20
Figure 5:	Monitoring and sampling a surface water supply treated with chlorine	21



# 1 Introduction

This booklet and the accompanying DVD *Checking it Out, Sampling and Monitoring for Small Drinking-Water Supplies* provides information about the supply of safe drinking-water to small water supplies serving fewer than 5000 people. For more information contact your regional Technical Assistance Programme (TAP).

This booklet describes methods for checking that drinking-water is safe. It includes sampling methods, use of simple instruments, and basic telemetry.

## 2 Why Should We Monitor?

It is important to know about the quality of the drinking-water supplied to a community to be sure that it is safe to drink. Water suppliers need to be aware of the contaminants that could be in a water source before the water is treated. Monitoring of water during and after treatment will provide information about the effectiveness of any treatment processes. Monitoring the water will also show whether the water complies with the New Zealand drinking water standards.

1. To ensure that water is safe to drink and meets drinking water standards.

Generally in New Zealand micro-organisms pose the greatest and most immediate risk of contamination to a water supply. There is also a variety of less serious problems with water supplies, such as taste, colour, odour and staining of clothes or fixtures that often cause concerns amongst a community. While not health related, these issues are signs of water quality problems that may need attention.

The New Zealand drinking-water standards give guidance about what are safe concentrations of contaminants in drinking-water and the minimum requirements for monitoring of a drinking-water supply. The requirements vary with the size and type of supply.

2. To identify the way in which changes in the quality of the raw water and in the treatment processes affect the quality of the final water delivered to consumers.

Monitoring source water enables a water supplier to be prepared for potential contamination issues and monitoring treated water enables a water supplier to assure a community of the quality of the water being supplied. Monitoring enables a water supplier to gain a better understanding of the performance of their drinking-water supply operation and management, and make better decisions about the supply.

3. Factors affecting the reliability of the results of monitoring.

It is important to remember however that any monitoring must be done with correct sampling techniques. Test results are only as good as the samples are representative.

Two factors affect the reliability of the results of monitoring;

- sampling procedures
- analytical procedures

The reliability of the results depends equally on these.

### 3 What Should We Be Testing For?

To know what is wrong or what needs fixing on a drinking-water supply, it is necessary to test the water. The tests that are needed are determined by the characteristics of the supply and the reason the tests are being done.

Table 1 below outlines a range of scenarios that might arise in a small drinking-water supply and the tests that could be undertaken in response.

**Table 1:** Recommended tests in response to key water quality issues

Issue	Recommended test
Need to ensure the water is microbiologically safe	<i>E. coli</i> bacteria, turbidity, pH and FAC if using chlorine, UV dose and flow rate if using UV disinfection.
Complaints of recurrent gastro-intestinal illness	<i>E. coli</i> bacteria, turbidity, pH and FAC if using chlorine
Water appears cloudy or coloured	Turbidity, colour
Scaly residues, soaps do not lather	Hardness, specific conductivity
Corrosion of pipes, plumbing	pH, alkalinity, lead, copper
Stained plumbing fixtures, laundry	Copper, iron, manganese
Objectionable taste or smell	Hydrogen sulphide, ammonia, metals, algae in source water
Nearby areas of intensive agriculture	Nitrate, pesticides, <i>E. coli</i> bacteria
Salty taste	Chloride, total dissolved solids, sodium

The frequency of this testing will vary from supply to supply, mostly based on risk – the higher the risk, the more frequent the monitoring required.

When making decisions about testing, it is useful to refer to the drinking-water standards for information on how often the water needs to be tested to demonstrate compliance with the standards. You may also undertake tests to see how well equipment is working. These are called process control tests. In addition to these tests, extra tests may be needed if things go wrong. Remember: the more knowledge you have, the more control you can have and therefore the more informed your decisions will be.

So the more frequently you sample and test, the greater the chances of picking up contamination events that occur intermittently – such as seepage or spray drift from farming activities, or contamination from road surface runoff.

#### 3.1 Sampling for micro-organisms

Sampling is an essential part of ensuring drinking-water is of good quality. It tells you whether the effort put into water treatment is effective and if you are providing acceptable water. The results of these tests are the evidence that is required to satisfy a drinking water assessor and your community that the water is not a risk to health. Sampling can give rise to as much error in your results as careless analysis.

The drinking water standards require water suppliers to monitor the quality of their water. The frequency and timing, however, are subject to various conditions and may vary from supply to supply. Sampling programmes intended to demonstrate compliance with the standards should be agreed with a drinking-water assessor at a public health unit before they are started.

## 4 How to Collect Samples Correctly

### 4.1 Sampling containers

Before any sampling is undertaken it is important to discuss the reason for sampling with the laboratory that will analyse the sample. Usually the sample containers are specific to the tests. Therefore, it is important to get the right container for the test being done. The correct sample container for each type of analysis will be provided by the laboratory. For microbiological tests, the sample bottle/container needs to be a wide-mouth vessel of at least 200 mL capacity and with a screw cap. For general chemical tests, a sample of 1–2 litres is usually required.

Samples for testing for micro-organisms in a drinking-water supply must be collected in containers that are pre-sterilised so that there are no living organisms in the bottles. Then any 'micro-organisms' found in the samples must have come from the water being tested (or from contamination while the sample was being taken). For some tests the sample bottles may contain substances required to stabilise or preserve the sample. Sample bottles for microbiological tests may contain sodium thiosulphate to neutralise any chlorine in the sample. For tests for some chemical contaminants, preservatives are included in the sample container. These will be added by the laboratory.

Whatever is being sampled for, the act of collection must be done with utmost care to reduce the possibility of contaminating the sample.

### 4.2 Sample identification and records

Immediately before or after collecting a sample, label the container clearly with information on:

- **where** – the sampling location, with sufficient detail to be able to repeat the sample from the same location, including the site code where possible.
- **why** – the reason for sampling (complaint, routine test, process control or compliance)
- **when** – the time and date of collection
- **who** – the name of the person collecting the sample (for traceability)
- **how** – the method of sample collection (ie, grab, first flush or full flush)
- **other** – weather conditions and any other useful observations.



In addition to this label and the sample itself, it is important to send laboratory delivery form. This form includes all the information given on the label plus some additional information that keeps track of the progress of the sample and identifies everyone who must deal with it, as illustrated in Example 1 below.

**Example 1:** Information on a sampling, analytical and laboratory delivery form

<b>Date and time</b>	31 February 2001 at 1430
<b>Person undertaking sampling</b>	Jo Smith
<b>WINZ supply code</b>	WAI004RE
<b>Specific location</b>	Outside tap of Sam Taylor's house, 75 Standard Street
<b>General location</b>	Zyzville
<b>Weather at time of sampling</b>	Fine
<b>Weather related observations</b>	Heavy rain two days ago
<b>Number of samples taken</b>	One
<b>Actions taken to collect sample</b>	Full flush
<b>Type of sample</b>	Grab
<b>Any sample preservation?</b>	Sterile bottle
<b>FAC level</b>	Zero (non-chlorinated)
<b>Label on bottle</b>	Yes

**Laboratory delivery**

<b>Date/time handed to courier</b>	31 February 2001 at 1600
<b>Laboratory destination</b>	LAB (Lloyds Analytical Blueville)
<b>Courier company</b>	GTE ('Get-there-eventually') couriers
<b>Courier ticket number</b>	Attach sticky label to package
<b>Date/time arrived at laboratory</b>	<i>Lab to fill</i>
<b>Who received sample</b>	<i>Lab to fill</i>

### 4.3 Sampling location

When planning a sampling programme it is necessary to need to plan for a range of factors in addition to the test itself. For example, where is the sample to be collected from, are there any safety issues related to collecting this sample, are any tests to be done on site – such as temperature, pH or chlorine?

Transporting the sample to the laboratory as quickly as possible is essential, as is cooling it down and keeping it out of the sunlight. So part of the preparation is to prepare a 'chilly bin' and cooler packs to keep the sample below 10°C until it arrives at the laboratory.

The sampling site needs to be representative of the part of the water supply that is being monitored.

#### 4.4 Samples from the environment – streams, springs, ponds

When taking a sample from a body of water it is best to hold the sample container in a clamp on the end of a pole. These devices can be purchased or made up quite simply. When taking a sample, water should be taken from about half a metre below the surface to avoid contamination that may be on the surface or in the settled material at the bottom.

If the water is flowing, hold the sample container open towards the water flow. If you need to stand in the water, collect the sample upstream from you, to avoid contaminating it. If there is no water flow, fill the container by pushing it away from you.

If the sample container contains a preservative, collect the sample without flushing the preservative out of the container.

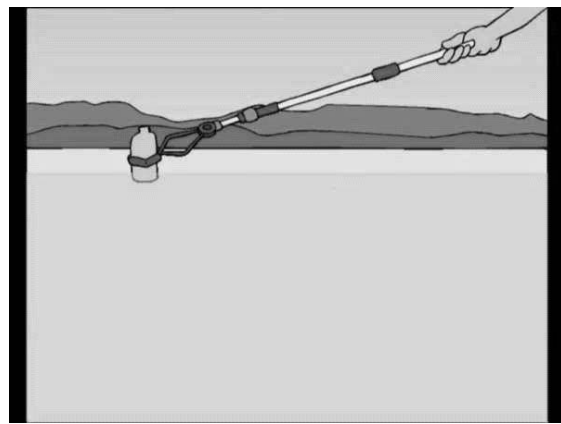

To sample at a specific depth, hold the sample container with the opening down until the correct depth is reached and then turn it the right way up so that the air flows out of the container and is replaced by the water.

**Sampling from a reservoir:** When taking a sample from a reservoir service line, it is necessary to flush any stale water out of the line and to ensure the reservoir water is drawn all of the way to the sample tap. Generally, 2–3 minutes of free flow is sufficient to produce about 20 litres of water.

Sometimes it may be useful to calculate the amount of water that needs to be flushed from a pipe. This can be done by estimating the volume to be flushed by substituting the pipe's radius ( $r$ , half the diameter) in the equation  $\pi r^2$  and multiplying the result by the length of the pipe to the sampling point, then multiplying the second result by five.

For example, for a sampling pipe that is 20 mm in diameter and 300 mm long:

Use  $\pi r^2 \times \text{length}$ , where  $r$  (half the diameter) = 10 mm:

$$\pi \times (10)^2 \times 300 = 94,247.78 \text{ litres}$$

Convert litres (L) to millilitres (mL) by dividing by 1000:

$$94,247.78 \div 1000 = 94.25 \text{ mL}$$

Then calculate the volume to flush out:

$$94.25 \times 5 = 471 \text{ mL}$$

So flush out about 500 mL from the line.

Sometimes, for a variety of reasons and although it is undesirable, it may be necessary to take samples directly from the reservoir water. This should be done in a similar way to taking a sample from a lake or pond.

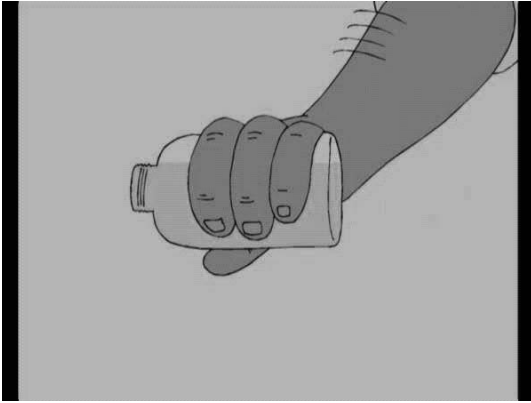

Remember reservoir water is potable water – water about to be consumed by others. Therefore, take special care not to introduce dirt and surface rubbish into the water and to sterilise equipment before sampling. If you need to put your hand and arm into the water make sure it has been thoroughly washed first. It is best to use a sample bottle holder on the end of a pole.

**Water treatment plant:** Sampling at a water treatment plant is usually done for either or both of two reasons. Compliance monitoring is used to demonstrate that the water produced by the treatment plant meets drinking water standards. Process monitoring is used to show how well a treatment process is working. Some treatment plants have continuous monitoring equipment for pH, turbidity and chlorine residuals. Water suppliers will also need to take grab samples for some parameters like *E. coli*.

When continuous monitoring equipment is used it is important to keep the sampling lines as short as possible. Samples need to be taken far enough downstream of where chemicals are added so those chemicals have had time to react before the place of sample collection.

All monitoring equipment will need to be regularly calibrated. The manufacturer's instructions will include details of how to do this and how often it needs to be done.

**Distribution system:** Samples should be collected at different locations in the distribution system including from the ends of the system. Samples can be collected from consumer's taps or designated sampling taps can be installed in parts of the system. When taking a microbiological sample, or sampling for chemical contaminants in the source water, the sample tap should be flushed for 2–3 minutes before the sample is taken. If taking a chemical sample to check if lead is leaching from the tap or plumbing fittings the tap should not be flushed, as it is necessary to collect the first flush of water from the tap after it has not been used for 12 hours.



#### 4.5 Microbiological sampling procedure

The following information is for sampling for microbiological quality from taps. Samples for chemical analysis have different procedures depending on the chemical being tested for and the reason for the test. When sampling for chemical parameters it is important to discuss the situation with a testing laboratory and have them outline the specific sampling procedure for the analysis being done.

Samples must be tested within 24 hours (preferably within six hours) and kept cool while in transit. The collection must be completed under clean conditions from disinfected taps and the samples must be accurately labelled. Prior to sampling, wash your hands, using at least soap and water or an antiseptic foam or alcohol gel.

Choose a suitable tap; preferably an unpainted metal tap that is not leaking. It should also be one that is used regularly and is not subject to contamination, for example from greasy hands or animals rubbing against it.

1. **Cleaning the tap:** Remove any attachments from the tap that may cause splashing. Use a clean cloth or paper to clean the outlet. Remove any dirt.
2. **Opening the tap; full flush:** Turn on the tap to maximum flow and allow water to run for 1-2 minutes. Sufficient water (at least 20 L) should have passed through the tap. Turn tap off.

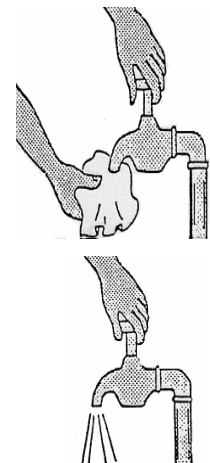

3. **Sterilising the tap:** For a metal tap, sterilise the tap for about 15 seconds with the flame from an ignited cotton-wool swab that has been soaked in 70 percent alcohol; alternatively, a gas burner may be used on a gentle flame. The aim is to heat up the water until it boils and forms steam to kill any bacteria on the tap; the aim is not to make the metal glow.

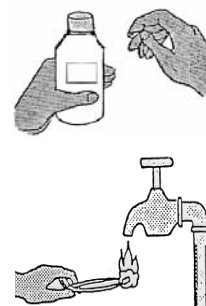

Spraying alcohol from a spray bottle or wiping with alcohol gel may also be suitable if the samples are for coliform bacteria detection as these micro-organisms are easy to kill. However, flaming is preferred when samples are to be analysed for other organisms.

If flaming the tap is impractical, it is possible to disinfect the tap by swabbing it (inside and outside) with a 1 percent sodium hypochlorite solution (for example, household bleach diluted one part bleach into two parts water in a spray bottle). Leave to stand for two to three minutes to disinfect the tap, and then proceed with Step 4 as below. Ensure that no bleach gets into the sample bottle and handle the bleach with care. Immediately wash off any bleach that comes into contact with skin.

4. **Opening the tap prior to sampling:** Carefully turn on the tap to a medium flow rate and allow the water to flow. Then reduce the flow rate. Do not change the flow rate while filling the bottle, as deposits may be dislodged.

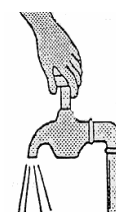

5. **Opening sterilised bottle:** The bottle will have been carefully prepared to be sterile until this moment so take great care in handling it. First, remove any protective cover and discard. Then open the container, with the bottle in one hand and the cap in the other. Do not place the cap on the ground or in your pocket, and do not touch the inside of the lid with your fingers. Hold the cap with the opening facing down. The inside of the cap can be easily contaminated which, in turn, can contaminate the water sample.

6. **Filling the bottle:** After opening, immediately hold the container under the flowing water and fill it to the shoulder but leave an air space. Do not overflow the bottle. Hold the lid with its open end downwards (to prevent entry of dust that might carry micro-organisms).



7. **Closing bottles:** Screw the lid firmly onto the container. Keep the container cool (less than 10°C) and in the dark by placing it in a chilly bin complete with ice or chilled cooler pads. Send the sample to the laboratory promptly so that it arrives within 24 hours (preferably within six hours) from the time of sampling. Direct contact with the laboratory is essential to keep all parties aware of the sample's progress. Remember the laboratory delivery form (see Section 4.2).

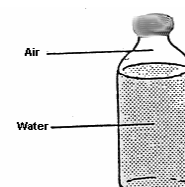

## 5 Testing Samples

The tests to be performed on a water sample will depend on what you want to know.

Some tests will be performed for operational purposes. For example, you may be checking whether the filters are removing particles effectively or if there is sufficient chlorine in the treated water.

Some tests will be for compliance with the drinking water standards. For example, it may be necessary to monitor for microbiological indicators like *E. coli* bacteria.

### 5.1 Who should do the testing?

Many tests, particularly tests for compliance with standards need to be performed by a specialist laboratory. Some tests, for example for temperature, pH, or chlorine residual need to be performed on site, as the sample can deteriorate before it reaches the laboratory.

All sample containers are specially prepared and should be obtained directly from the laboratory before any samples are collected. Contact the laboratory before you send any samples so that their staff know to expect them.

The laboratory will also advise about the volume of sample to be collected. The volume required will depend on the tests to be performed. Microbiological tests require at least 100 mL (the minimum volume) while most chemical tests require volumes of up to 2 litre. Sample containers for microbiological tests may have a dechlorinating chemical, sodium thiosulphate added to the sample container. This is to prevent the chlorine from continuing to disinfect the water sample before it is tested.

If samples are taken to demonstrate compliance with the drinking-water standards, the laboratory that tests the samples must be a Ministry of Health recognised laboratory. For details of these laboratories, check online at <http://www.moh.govt.nz> or <http://www.drinkingwater.org.nz/>. Another alternative is to search on the Internet for Register of Recognised Laboratories Drinking Water Supplies.

For some remote sites, it may not be possible to get a sample to an approved laboratory in a reasonable amount of time. If so, talk to your drinking water assessor about what options are available.



### 5.2 Description of tests

#### pH

pH is the measure of how acidic or alkaline a water sample is, on a scale from 0 to 14. Neutral is 7; values less than 7 are acidic and values greater than 7 are alkaline. The scale is logarithmic, so a pH of 5 is 10 times more acidic than a pH of 6. The lower the pH, the stronger the acidity.

Drinking-water pH should be between 6.5 and 8.5; preferably between pH 7.0 and 8.0.

pH is measured either by a calibrated pH meter or by using colour-changing chemicals (like phenol red or bromothymol blue). It is important to check that people doing colour change tests are not colour blind.

### Measuring with a pH meter and probe

Special care must be taken with the probe as it is the instrument that actually does the measuring. The bulb at the tip of the probe is a sensitive glass membrane that must not be scratched or rubbed. Oil or grease can 'blind' the probe and make it inaccurate. Also, never dry the probe or wipe it with tissues; always rinse it with distilled water instead.

The meter's role is to translate the measurements the probe makes into numbers we read. So the two parts of the instrument work together.

The pH meter must be calibrated (ie, checked against known standards, usually 4.00 and 7.00 buffers) before use. The supplier of this equipment will provide information and instructions on calibration. Always use reagents that have not past their use by date, and rinse the probe in de-ionised water.

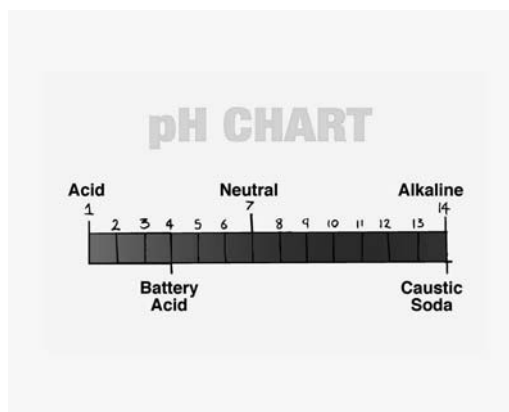

### Measuring with pH colour-changing methods

With a pH colour-changing method, a tablet or liquid indicator is added to a small sample of water changing the colour of the water. Then the colour changes are compared to those on a colour chart or colour disc. For example; a common chemical used for pH is phenol red, which changes yellow (6.8) to red (8.4).

A disadvantage with the colour-changing system is that the colour changes over a limited pH range. If the pH is higher or lower than the test can measure, the colours will be the same as the highest or lowest colours of the scale they are being compared to on the colour disc or chart, leading to errors.

For example; if the pH were 4.4, the phenol red indicator would be yellow, the same as if the pH were 6.8. Therefore if the colour shown by the test kit is at its extreme it may be necessary to use different colour discs and reagents or the water must be tested using a calibrated pH meter.

It is important to remember that very high chlorine concentrations can affect the colour when doing pH tests.

## Chlorine

Chlorine is the disinfectant that kills most micro-organisms in drinking-water except *Cryptosporidium*. If chlorine is being used it is important to maintain a chlorine residual so that the amount of chlorine in the water will be sufficient to kill the micro-organisms in the water. Therefore it is necessary to test for the level of chlorine residuals.

### Measuring with FAC, CAC and TAC tests

The tests for chlorine residual levels are for:

- free available chlorine (FAC), which tells us the level of chlorine that is instantly available to kill micro-organisms
- total available chlorine (TAC), which tells us both FAC and combined available chlorine (CAC), which is chlorine that has already reacted with material in the water and can still kill micro-organisms but takes a while to do so. In fact, CAC can cause taste and odour problems so ideally it should be as low as possible. FAC levels can be monitored continuously, and most large treatment plants do this.

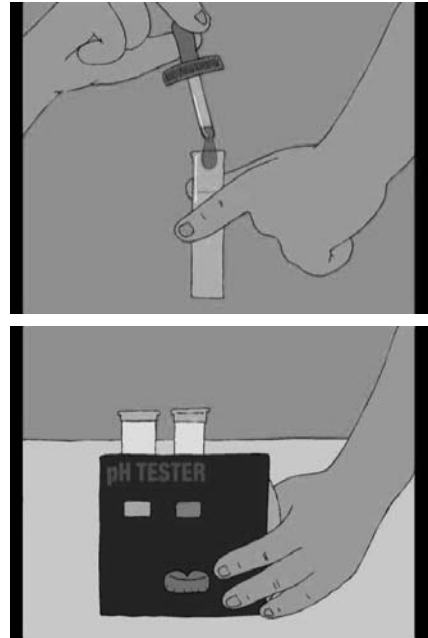

### TAC test result minus FAC test result = CAC level (TAC – FAC = CAC)

Both FAC and TAC test methods can be done using a colour change test using a chemical called DPD which is available as liquid, powder or tablets. The FAC test uses DPD#1 tablets or powder. The TAC test uses DPD#4 tablets or powder. The DPD reagents have a limited shelf life and must be stored at room temperature and away from light. If this chemical is brown or pink it should not be used.

The FAC test should give a pink or red colour. The darker the colour, the more chlorine that is present.

- Unfortunately, too much chlorine can bleach the colour, giving a false negative result. When no FAC is recorded and the FAC test shows no colour, a TAC test should be done.
- If FAC shows no colour and the TAC test is clear, there is no chlorine.
- If FAC shows no colour and the TAC test is pink or red, only CAC exists. This is undesirable as it produces strong tastes and odour and there is not chlorine available to kill micro-organisms.
- If FAC shows no colour and the TAC test is yellow, there is excessive FAC

These tests can be done using a variety of colour comparator kits (visual or electronic) or chemical titration.

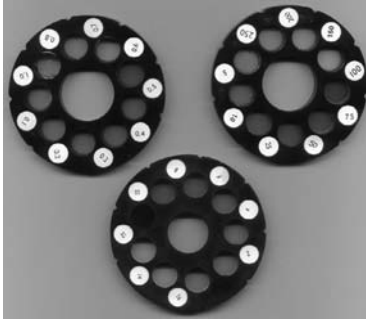

**Lovibond comparator discs**

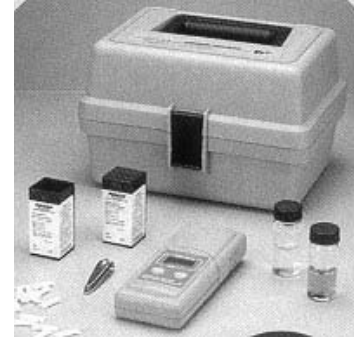

**Photometer and test kit**

The DPD test will only determine chlorine residuals accurately if they are below 4 mg/L. If the test result is higher than this, repeat the test with a diluted water sample. For example, dilute the sample with water that has no chlorine such as rainwater or distilled water – if you dilute by half, multiply the test result by 2, and so on.

### **Turbidity**

Turbidity is the measure of particles suspended in the water. Like dust in the sun, turbidity is best seen when lit up against a dark background. A turbidimeter measures the level of suspended material by shining a light through a sample of water. The more particles 'seen' by the detector, the higher the turbidity level will be. Turbidity is measured as nephelometric turbidity units (NTU).



### **Measuring with a turbidimeter**

Like all scientific equipment, the turbidimeter (or turbidity meter) must be calibrated before use (using standards made from a chemical called formazin) and appropriately maintained. Dirty glassware, air bubbles, finger marks, and so on will give false readings.

To do a turbidity test, a clean glass tube is filled with a sample of the water. It is placed in a slot in the turbidity meter which then gives a reading of the turbidity level or NTU on a small screen. It would not be possible to distinguish between 1, 0.1 and .01 NTU with naked eye, but turbidity meters do this. Ideally drinking-water should have a turbidity reading of less than 1NTU.



### Testing for the indicator organism, *E. coli*

Usually testing for micro-organisms requires specialist laboratory equipment and techniques. However, test kits are available for on-site work. Instead of testing for the actual numbers of micro-organisms, presence or absence (P/A) tests detect whether or not the sample tested contains one or more micro-organisms. If one or more micro-organisms, usually faecal coliforms or *E. coli* are detected, the test gives a presence result. If there is no reaction in the test, then it is established that those micro-organisms are absent.

*E. coli* bacteria can be detected with this straightforward kind of 'rapid' test method. The test comes in a kitset form, in which all equipment is pre-sterilised.

Using this method, the test container is filled aseptically (ie, without contaminating the sample) with the carefully collected sample, the sample is incubated (kept warm at 35°C) for 24 hours, then the resulting colour is observed. It is called the chromogenic broth or enzyme substrate test method because, if the tested sample produces a colour that fluoresces (glows) when lit by a UV or 'black' light, this confirms the presence of *E. coli*. There are a number of brands of this test available.



## 6 Remote Monitoring and Alarms

When the monitored level of a parameter exceeds the level that is considered to be safe, an alarm should alert a water supplier that action needs to be taken. Alarms are normally associated with levels that are continuously measured, such as reservoir levels, pump operation, chlorine residuals or turbidity levels.

The alarm allows quality to be controlled without someone being at the treatment plant all the time. It allows actions to be taken quickly, as long as the alarm is monitored adequately. Notification that an alarm has been activated can be audible – if someone is at the plant – or via telemetry (a text message).

In some cases, control can then be achieved via an Internet link to a computer. A system like this can have a series of phone numbers on an autodialing system so that, if someone does not respond to the alarm within a given time, the next person on the list will be contacted.

An alarm has to be able to give warning of a problem that will require action – such as a reduced water flow. Urgent alarms, such as one to notify that the chlorine has run out or the turbidity leaving the filters is too high, will require immediate action. If an operator cannot get to the plant in time, it may be necessary to have some system in place to shut the plant down until someone can get to the site to fix the problem.

Some alarm measurements can simply determine whether the flow is on or off, or whether the level is high or low. Others require continuous measurements whether they are displayed or not. While the actual levels are being monitored all the time, an alarm only goes off when a predetermined level is reached. For example, if the FAC was less than 0.2 mg/L, an alarm would be activated.

## 7 Recording and Storing Results

All results must be recorded and stored in a way that allows them to be easily located again. It is recommended that records are kept on formatted sheets, either paper or computer-based.

On these sheets it is important to include the target levels so that all readings can be compared to them. These values may help you identify the need to take corrective action as appropriate. One possible pro forma sheet is illustrated in Example 2 below.

**Example 2:** Pro forma sheet for test results

Date sample taken	Person taking sample	Laboratory undertaking analysis
Sample identifier	Place sample taken from	Reason for sampling
Method of sample collection (grab, first flush etc)	Weather conditions if appropriate	Other relevant information
Test	Sample # and units	Target level
Free available chlorine	mg/L	Greater than 0.2 mg/L but less than 2.0 mg/L
pH		6.5–8.5, ideally 7.0–8.0
Turbidity		Less than 0.20 NTU
<i>E. coli</i> (laboratory results)	/100 mL	Less than 1/100 mL

Data collected should be assessed daily and over time to determine both immediate actions required and any trends that are emerging.

## 8 Worked Examples

### 8.1 Example A: Secure groundwater

**Figure 1:** Monitoring and sampling a secure groundwater source

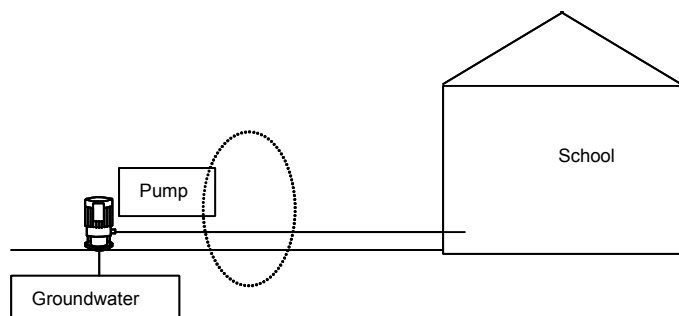

A school uses a groundwater source that has been analysed to determine that the water is 'secure'. This means that it has been under ground and not influenced by surface water for long enough to be free of contamination. Some routine monitoring is required to check that it continues to be of acceptable quality.

However, once the water is out of the ground, it has the potential to be contaminated. So samples will need to be taken after the pump from a special sampling point (see Figure 1). Care is needed to ensure that during sampling, the water supplies (and the sample) are not contaminated.

### 8.2 Example B: Roof supply + chlorine addition

**Figure 2:** Monitoring and sampling roof water treated with chlorine

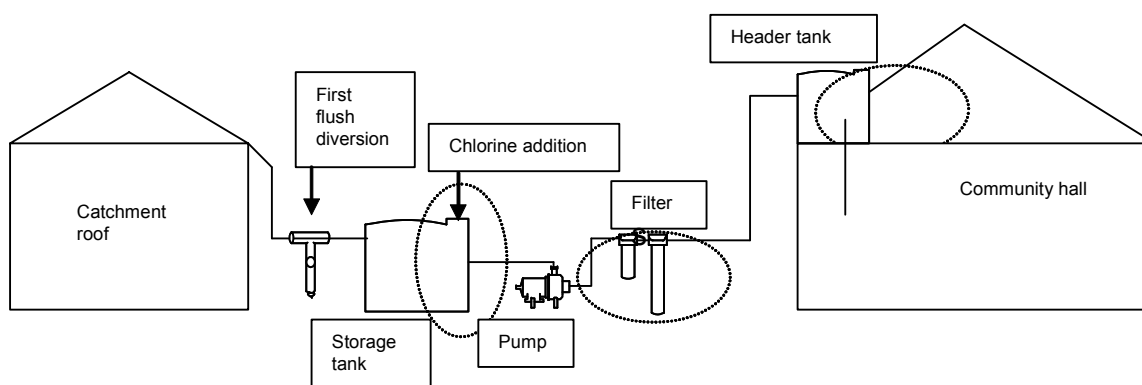

Roof supplies have the potential to be contaminated from many sources – including birds and other wildlife defecating on the roof, chemical contamination from aerial spraying, fumes from fires, or just wind-blown dust and dirt.

In-ground tanks can also be at risk from ground water seepage.

Therefore, water collected from the roof will be subject to chemical, biological and physical contamination. Chlorine (Figure 2) will control the micro-organisms, provided that other organic matter does not use it up first.

- Monitoring (sampling) for pH, FAC, turbidity and *E. coli* will be required at the point where consumption is likely, such as the kitchen tap. Only *E. coli* testing is likely to be needed for compliance – but the other tests will help to demonstrate the operational performance of the treatment equipment.
- Monitoring the tank levels of the chlorine dosing solution will be required but may be done manually or remotely, depending on the volume of fluid available and the frequency of visits to the treatment plant, while the pressure loss across the filters will help to determine when they will need to be replaced.

### 8.3 Example C: Roof supply + UV light

**Figure 3:** Monitoring and sampling roof water treated with a UV system

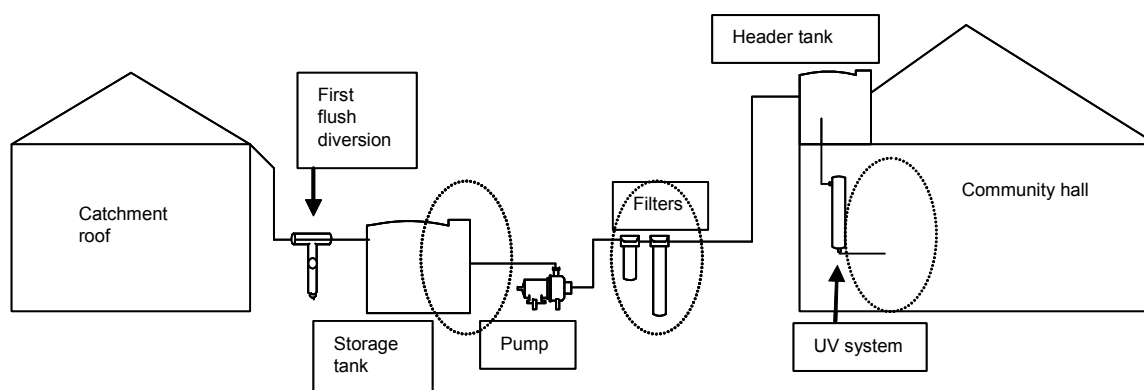

Here the water source and risks associated with its use are similar to Example B above, except that UV light (Figure 3) irradiates the water to control the micro-organisms so there are minimal chemical requirements.

- Frequent monitoring (sampling) for pH, turbidity and *E. coli* will be required at the point where consumption is likely. Only *E. coli* testing is likely to be needed for compliance – but the other tests will help to demonstrate the operational performance of the treatment equipment and tank.
- Regular monitoring should include:
  - the water levels
  - the pressure loss across the filters, which will help to determine when the filters will need to be replaced
  - UV light intensity and/or transmittance
  - equipment condition and level of cleanliness of the roof
  - UV disinfection appliance performance tests specified by the manufacturer or by the drinking water standards.

## 8.4 Example D: Groundwater + chlorine

**Figure 4:** Monitoring and sampling a groundwater source treated with chlorine

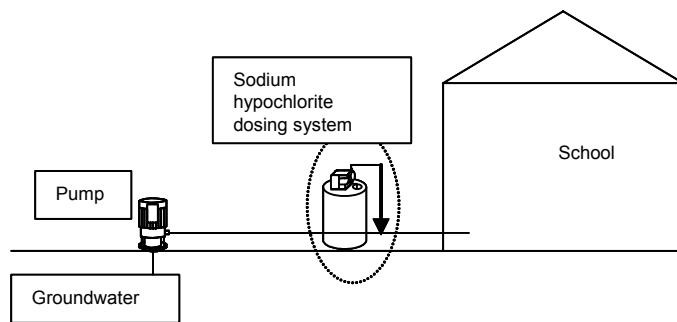

This example is similar to Example A but includes the addition of chlorine. Chlorine will usually only be used if the groundwater is not secure and is at risk of microbiological contamination.

- Frequent monitoring (sampling) for pH, FAC, turbidity and *E. coli* will be required at the point where consumption is likely, such as the drinking fountain. Only *E. coli* testing is likely to be needed for compliance – but the other tests will help to demonstrate the operational performance of the treatment equipment.
- Monitoring the tank levels of the chlorine dosing solution will be required but may be done manually or remotely depending on the volume of fluid available and the frequency of visits to the treatment plant.

## 8.5 Example E: Surface water + chlorine for a town supply

Figure 5: Monitoring and sampling a surface water supply treated with chlorine

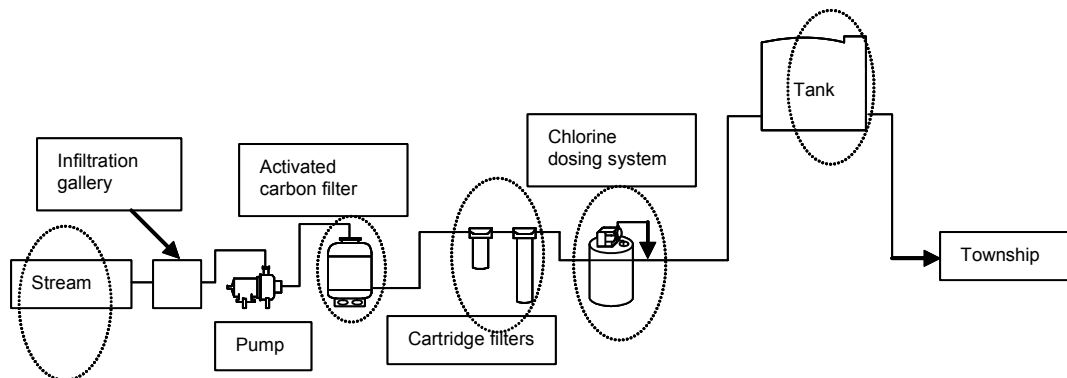

Because a surface water source is used to provide the town's water, there is potential for contamination from a wide range of sources. Basic treatment will make this water acceptable. However, each step in the treatment (Figure 5) will need monitoring for operations and performance.

- The risks to the quality of the stream source should be identified in the risk management plan and catchment survey. Pesticides from a fruit orchard, run off from paddock used to graze sheep or cattle, agricultural use of fertiliser, or turbidity changes after a rain event are examples of things that could cause problems. The source should be monitored for pH, temperature and turbidity, particularly at times where risks are the greatest.
- Pumping hours will need to be recorded.
- In the long term, relationships between water quality and weather patterns could be developed.
- Filter headloss measurements should be noted and recorded.
- The pressure loss across the cartridge filters will need to be monitored to indicate when they will need to be replaced.
- Chemical dose rates need to be checked.
- The need for activated carbon filter replacements is dependent on the water volume passed through filter.
- Monitoring the levels of the chlorine dosing solution will be required. Frequency of the visits may be determined by the available volume of chemicals that can be stored.
- Frequent monitoring (sampling) for pH, FAC, turbidity and *E. coli* will be required at the points where consumption is likely. Only *E. coli* testing is likely to be needed for compliance – but the other tests will help to demonstrate the operational performance of the treatment equipment.
- To ensure the water quality is acceptable throughout the town's distribution system, a series of sampling points need to be set up.

- Regular measurement and recording of the volumes of water treated will allow some trends over time to be established. This will help to identify patterns of water use and possibly water wastage or leakage in the reticulation system.
- It would also be useful to test the water leaving the storage tank. This will allow comparison of treated water quality with the water being consumed – especially if there is demand for chlorine in the pipework for the town.